



Agilent 7890A Gas Chromatograph

Advanced User Guide

Notices

© Agilent Technologies, Inc. 2009

No part of this manual may be reproduced in any form or by any means (including electronic storage and retrieval or translation into a foreign language) without prior agreement and written consent from Agilent Technologies, Inc. as governed by United States and international copyright laws.

Manual Part Number

G3430-90015

Edition

Fifth edition, September 2009

Fourth edition, April 2009

Third edition, September 2008

Second edition, January 2008

First edition, April 2007

Printed in USA

Agilent Technologies, Inc.
2850 Centerville Road
Wilmington, DE 19808-1610 USA

安捷伦科技（上海）有限公司
上海市浦东新区外高桥保税区
英伦路 412 号
联系电话：（800）820 3278

Safety Notices

CAUTION

A **CAUTION** notice denotes a hazard. It calls attention to an operating procedure, practice, or the like that, if not correctly performed or adhered to, could result in damage to the product or loss of important data. Do not proceed beyond a **CAUTION** notice until the indicated conditions are fully understood and met.

WARNING

A **WARNING** notice denotes a hazard. It calls attention to an operating procedure, practice, or the like that, if not correctly performed or adhered to, could result in personal injury or death. Do not proceed beyond a **WARNING** notice until the indicated conditions are fully understood and met.

Firmware Version

This manual is written for 7890A GCs using firmware version A.01.10.1.

Contents

1 Programming

Run Time Programming	14
Using run time events	14
Programming run time events	15
The run table	15
Adding events to the run table	15
Editing events in the run table	15
Deleting run time events	16
Clock Time Programming	17
Using clock time events	17
Programming clock time events	17
Adding events to the clock table	17
Editing clock time events	18
Deleting clock time events	18
User-Key Programming	19
To program a User Key	19
To play back (execute) the stored keystrokes	19
To erase the stored keystrokes	19

2 Configuration

About Configuration	23
Assigning GC resources to a device	23
Setting configuration properties	24
General Topics	25
Unlock the GC Configuration	25
Ignore Ready =	25
Information displays	25
Unconfigured:	26
Oven	27
To configure the oven	27
To configure the oven for cryogenic cooling	28
Front Inlet/Back Inlet	29
To configure the Gas type	29
To configure the PTV or COC coolant	29
To configure the MMI coolant	31
Column #	33
To configure a single column	33
To configure multiple columns	35

Cryo Trap	40
Configure the cryo trap to the GC	40
Configure a heater to the cryo trap	40
Configure the coolant	40
Configure the user-configurable heater	41
Reboot the GC	41
Front Detector/Back Detector/Aux Detector/Aux Detector 2	42
To configure the makeup/reference gas	42
Lit offset	42
To configure the FPD heaters	42
Analog out 1/Analog out 2	43
Fast peaks	43
Valve Box	44
To assign a GC power source to a valve box heater	44
Thermal Aux	45
To assign a GC power source to an Aux thermal zone	45
To configure an MSD transfer line heater	45
To configure a nickel catalyst heater	46
To configure an AED transfer line heater	46
PCM A/PCM B/PCM C	47
To assign a GC communication source to a PCM	47
To configure a PCM	47
Pressure aux 1,2,3/Pressure aux 4,5,6/Pressure aux 7,8,9	49
To assign a GC communication source to an Aux EPC	49
To configure an auxiliary pressure channel	49
Status	50
The Ready/Not Ready status table	50
The setpoint status table	50
To configure the setpoint status table	50
Time	51
To set time and date	51
To use the stopwatch	51
Valve #	52
To configure a valve	52
Front injector/Back injector	53
Solvent Wash Mode (7683 ALS)	53
To configure an injector (7683 ALS)	54
Sample tray (7683 ALS)	55
Instrument	56

3 Options

- About Options 58
- Calibration 59
 - Maintaining EPC calibration—inlets, detectors, PCM, and AUX 59
 - To zero all pressure sensors in all modules 61
 - Column calibration 61
- Communication 65
 - Configuring the IP address for the GC 65
- Keyboard and Display 66

4 Chromatographic Checkout

- About Chromatographic Checkout 68
- To Prepare for Chromatographic Checkout 69
- To Check FID Performance 71
- To Check TCD Performance 76
- To Check NPD Performance 81
- To Check uECD Performance 86
- To Check FPD Performance (Sample 5188-5953) 91
- To Verify FPD Performance (Sample 5188-5245) 98

5 Methods and Sequences

- Creating Methods 106
 - To program a method 107
 - To program the ALS 107
 - To program the ALS sampler tray 107
 - To program the 7683B ALS bar code reader 108
 - To save a method 109
 - To load a stored method 109
 - Method mismatch 109
- Creating Sequences 111
 - About the priority sequence 111
 - To program a sequence 111
 - To program a priority sequence 112
 - To program an ALS subsequence 113
 - To program a valve subsequence 113
 - To program post sequence events 113
 - To save a sequence 114
 - To load a stored sequence 114
 - To determine sequence status 114

To start a sequence	114
To pause and resume a sequence	115
To stop a sequence	115
To abort a sequence	115

6 Checking for Leaks

Preparing the GC for Maintenance	118
Column and oven preparation	118
Inlet preparation	118
Detector preparation	118
Leak Check Tips	119
To Check for External Leaks	120
To Check for GC Leaks	121
Leaks in Capillary Column (Microfluidic) Fittings	122
To Perform a SS Inlet Pressure Decay Test	123
To Correct Leaks in the Split Splitless Inlet	127
To Perform a Multimode Inlet Pressure Decay Test	128
To Correct Leaks in the Multimode Inlet	132
To Perform a PP Inlet Pressure Decay Test	133
To Correct Leaks in the Packed Column Inlet	137
To Perform a COC Pressure Decay Test	138
To Correct Leaks in the Cool On-Column Inlet	141
To Perform a PTV Pressure Decay Test	142
To Correct Leaks in the PTV Inlet	146
To Perform a VI Pressure Decay Test	147
To Prepare the VI for a Closed System Leak Check	150
To Correct Leaks in the Volatiles Interface	151

7 Flow and Pressure Modules

About Flow and Pressure Control	154
Maximum operating pressure	154
PIDs	155
Inlet Modules	156
Detector Modules	157
Pressure Control Modules	158
Auxiliary Pressure Controllers	161

Restrictors	162
Examples	163
1. Using an Aux epc channel to supply purge gas to a splitter	163
2. Using the PCM channels	163

8 Inlets

Using Hydrogen	167
Inlet Overview	168
Carrier Gas Flow Rates	169
About Gas Saver	170
To use gas saver	170
Pre Run and Prep Run	171
The [Prep Run] key	171
Auto Prep Run	172
About Heaters	173
About the Split/Splitless Inlet	175
Septum tightening (S/SL)	175
Standard and high-pressure versions of the S/SL inlet	175
Split/Splitless inlet split mode overview	176
Split/Splitless inlet splitless mode overview	177
The S/SL inlet pulsed split and splitless modes	178
Split/Splitless inlet split mode minimum operating pressures	179
Selecting the correct S/SL inlet liner	180
Vapor Volume Calculator	182
Setting parameters for the S/SL split mode	182
Selecting parameters for the S/SL splitless mode	183
Setting parameters for the S/SL splitless mode	184
Setting parameters for the S/SL pulsed modes	185
About the Multimode Inlet	186
Septum tightening (MMI)	186
Heating the MMI	187
Cooling the MMI	187
MMI split mode minimum operating pressures	188
Selecting the correct MMI liner	189
Vapor Volume Calculator	191
MMI split and pulsed split modes	191
MMI splitless and pulsed splitless modes	194
MMI solvent vent mode	201
MMI Direct Mode	209
To develop a MMI method that uses large volume injection	210

Multiple injections with the MMI	213
About the Packed Column Inlet	219
Setting parameters	220
About the Cool On-Column Inlet	222
Setup modes of the COC inlet	223
Retention gaps	223
COC inlet temperature control	223
Setting COC inlet flows/pressures	224
Setting COC inlet parameters	225
About the PTV Inlet	226
PTV sampling heads	226
Heating the PTV inlet	227
Cooling the PTV inlet	228
PTV inlet split and pulsed split modes	228
PTV inlet splitless and pulsed splitless modes	232
PTV inlet solvent vent mode	239
To develop a PTV method that uses large volume injection	247
Multiple injections with the PTV inlet	250
About the Volatiles Interface	255
VI operating modes	256
About the VI split mode	257
About the VI splitless mode	261
About the VI direct mode	266
Preparing the Interface for Direct Sample Introduction	269
Disconnecting the split vent line	269
Configuring for direct mode	271
VI direct mode setpoint dependencies	271
VI direct mode initial values	271
Setting parameters for the VI direct mode	272

9 Columns and Oven

About the Oven	276
Oven safety	276
Configuring the Oven	277
Cryogenic Operation	278
Cryogenic setpoints	278
About Oven Temperature Programming	280
Programming setpoints	280
Post run	281
Oven ramp rates	281

Setting the oven parameters for constant temperature	282
Setting the oven parameters for ramped temperature	282
About the Oven Insert	284
About Columns	285
Selecting the correct packed glass column type	285
About the column modes	285
Select a column mode	286
Setting the column parameters for constant flow or constant pressure	287
Enter a flow or pressure program (optional)	287
Programming column pressure or flow	288
Backflushing a Column	289
Backflushing when connected to an MSD	289
Backflushing using a capillary flow technology device	290
Nickel Catalyst Tube	295
About the nickel catalyst tube	295
Nickel catalyst gas flows	295
Setting temperatures for the nickel catalyst tube	296

10 Detectors

About Makeup Gas	298
About the FID	299
How FID units are displayed in Agilent data systems and on the GC	300
To light the FID flame	300
To extinguish the FID flame	300
FID automatic reignition (Lit offset)	301
Recommended starting conditions for new FID methods	301
Setting parameters for FID	302
About the TCD	304
TCD pneumatics	306
TCD carrier, reference, and makeup gas	306
TCD gas pressures	307
Selecting reference and makeup flows for the TCD	308
Chemically active compounds reduce TCD filament life	308
Changing the TCD polarity during a run	309
Detecting hydrogen with the TCD using helium carrier gas	309
Setting parameters for the TCD	309
About the uECD	312
uECD safety and regulatory information	312
uECD warnings	313
Safety precautions when handling uECDs	315

uECD gas flows	316
uECD linearity	316
uECD detector gas	316
uECD temperature	316
uECD analog output	317
Recommended starting conditions for new uECD methods	317
uECD makeup gas notes	317
uECD temperature programming	318
Setting parameters for the uECD	318
About the NPD	319
New NPD features and changes	319
NPD software requirements	319
NPD flows and general information	319
NPD flow, temperature, and bead recommendations	320
NPD required gas purity	322
Setting parameters for the NPD	323
Selecting an NPD bead type	324
Changing from a ceramic bead to a Blos bead	325
Selecting an NPD jet	325
To configure the NPD	326
Automatically adjusting NPD bead voltage	327
Setting NPD adjust offset on the clock table	328
Aborting NPD adjust offset	328
Extending the NPD bead life	328
Setting the initial bead voltage for new beads	329
Setting NPD bead voltage manually (optional)	329
About the FPD	331
FPD linearity	332
FPD Lit Offset	332
Starting Up and Shutting Down the FPD	332
FPD photomultiplier protection	332
FPD optical filters	332
Inlet liners for use with the FPD	333
FPD temperature considerations	333
FPD gas purity	333
FPD gas flows	333
Lighting the FPD flame	334
Setting parameters for the FPD	335

11 Valves

About Valves	338
The Valve Box	339

Heating the valves	339
Valve temperature programming	339
Configuring an Aux thermal zone	340
Valve Control	341
The valve drivers	341
The internal valve drivers	341
The external valve drivers	342
Valve Types	343
Configuring a Valve	344
Controlling a Valve	345
From the keyboard	345
From the run or clock time tables	345
Simple valve: column selection	345
Gas sampling valve	346
Multiposition stream selection valve with sampling valve	347

12 7683B Sampler

About the 7683B Sampler	350
Hardware	350
Software	350
Setting Parameters for the ALS	351
Solvent Saver	352
Sample tray setpoints	353
Storing setpoints	353

13 Cables

About Cables and Back Panel Connectors	356
Back panel connectors	356
Sampler connectors	356
The AUX connector	356
Signal connectors	357
REMOTE connector	357
EVENT connector	357
BCD input connector	357
RS-232 connector	357
LAN connector	357
Using the Remote Start/Stop cable	358
Connecting Agilent products	358
Connecting non-Agilent products	358
Connecting Cables	361

Cable Diagrams	363
Analog cable, general use	363
Remote start/stop cable	363
BCD cable	364
External event cable	365

14 GC Output Signals

About Signals	368
Signal Types	369
Value	369
Analog Signals	371
Analog zero	371
Analog range	371
Analog data rates	372
Selecting fast peaks (analog output)	373
Digital Signals	374
Digital zero	374
Baseline level shifts	374
Agilent data systems	375
Zero Init Data Files	377
Column Compensation	378
Creating a column compensation profile	379
Making a run using analog output column compensation	379
Making a run using digital output column compensation	379
Plotting a stored column compensation profile	380
Test Plot	381

15 Miscellaneous Topics

Auxiliary Devices	384
About Auxiliary Pressure Control	384
About Aux Thermal Zone Control	385
About Auxiliary Device Contacts	385
About the 24V Auxiliary Device Power Supply	385
About Auxiliary Columns	385
About Auxiliary Detectors	386
To Use the Stopwatch	387
Service Mode	388
Service Reminders	388
Other functions	389



1 Programming

Run Time Programming	14
Using run time events	14
Programming run time events	15
The run table	15
Adding events to the run table	15
Editing events in the run table	15
Deleting run time events	16
Clock Time Programming	17
Using clock time events	17
Programming clock time events	17
Adding events to the clock table	17
Editing clock time events	18
Deleting clock time events	18
User-Key Programming	19
To play back (execute) the stored keystrokes	19
To erase the stored keystrokes	19
To program a User Key	19

Run Time Programming

Run time programming allows certain setpoints to change automatically during a run as a function of the chromatographic run time. Thus an event that is programmed to occur at 2 minutes will occur 2 minutes after every injection.

Its uses include:

- Controlling column switching or other valves
- Changing signal definition, zero, or range
- Controlling an auxiliary pressure channel
- Changing polarity of a thermal conductivity detector (TCD)
- Turning the hydrogen flow to a nitrogen- phosphorus detector (NPD) on or off
- Pausing (freezing) and resuming a signal value

The changes are entered into a run table that specifies the setpoint to be changed, the time for the change, and the new value. At the end of the chromatographic run, most setpoints changed by a run time table are returned to their original values.

Valves can be run time programmed but are *not* restored to their starting position at the end of the run. You must program the reset operation in the run table if this action is desired. See [“From the run or clock time tables”](#) on page 345.

Using run time events

The **[Run Table]** key is used to program timed events.

You can control the following events during a run.

- Valves (1- 8)
- Multiposition valve
- Signal type (see [“Signal Types”](#) on page 369)
- Analog signal zero and range
- Digital signal zero and baseline level shifts (see [“Digital zero”](#) on page 374)
- Auxiliary pressures (1 through 9)
- TCD negative polarity (on/off)
- NPD H₂ flow (on/off)
- Pausing (freezing) and resuming a signal value

Programming run time events

- 1 Press [**Run Table**].
- 2 Press [**Mode/Type**] to see the available run time events.
- 3 Scroll to the event to be programmed. Press [**Enter**].
- 4 Enter values for the **Time:** and the other parameter. Press [**Enter**] after each entry.
- 5 Press [**Mode/Type**] to add another event. Press [**Status**] to terminate entries.

The run table

The programmed events are arranged in order of execution time in the Run Table. This is a brief example:

RUN TABLE (1 of 3)	Event 1 rotates a valve.
Time: 0.10	
Valve #2 On	
RUN TABLE (2 of 3)	Event 2 adjusts the signal range.
Time: 3	
Analog signal 2 range 2	
RUN TABLE (3 of 3)	Event 3 resets Valve #2 to its original position in preparation for another run. Valves do not reset automatically.
Time: 4.20	
Valve #2 Off	

Adding events to the run table

- 1 To add new events to the run table, press [**Mode/Type**] while on the **Time:** line of any entry.
- 2 Select the event type.
- 3 Set appropriate **Time:** and other parameters. Some require numbers; others require [**On/Yes**] or [**Off/No**].
- 4 Repeat until all entries are added. Events are automatically placed in order by execution time.

Editing events in the run table

- 1 Press [**Run Table**].
- 2 Move the cursor to the event you want to change.
- 3 To edit the time for an event, move the cursor to the line labeled **Time:**. Type the desired time and press [**Enter**].
- 4 To edit a setpoint value, scroll to the setpoint line. Press [**On/Yes**] or [**Off/No**] or enter a numeric value for the setpoint. Press [**Enter**].

Deleting run time events

- 1 Press [**Run Table**].
- 2 From within this table press [**Delete**] to delete events from the run time table. You will be asked to confirm the deletion.
- 3 Press [**On/Yes**] to delete the current timed event; press [**Off/No**] to cancel this operation.
- 4 To delete the entire table, press [**Delete**][**Run Table**].

Clock Time Programming

Clock time programming allows certain setpoints to change automatically at a specified time during a 24- hour day. Thus, an event programmed to occur at 14:35 hours will occur at 2:35 in the afternoon. A running analysis or sequence has precedence over any clock table events occurring during this time. Such events are not executed.

Possible clock time events include:

- Valve control
- Method and sequence loading
- Starting sequences
- Initiating blank and prep runs
- Column compensation changes
- Adjustments of the detector offset

Using clock time events

The Clock Table function allows you to program events to occur during a day based on the 24- hour clock. Clock table events that would occur during a run or sequence are ignored.

For example, the clock table could be used to make a blank run before you even get to work in the morning.

Programming clock time events

- 1 Press [**Clock Table**].
- 2 Press [**Mode/Type**] to see the available clock time events.
- 3 Scroll to the parameter to be programmed.
- 4 Edit **Time:** and the setpoints for this event.
- 5 Press [**Mode/Type**] to add another event. Press [**Status**] to terminate entries.

When the clock event is executed, a confirming message appears.

Adding events to the clock table

- 1 Press [**Clock Table**].
- 2 Press [**Mode/Type**]. When entries are added, they are automatically ordered chronologically.
- 3 Select the event type.
- 4 Set appropriate parameters.

- 5 Repeat this process until all entries are added.

Editing clock time events

- 1 Press [**Clock Table**] to view all events programmed.
- 2 Scroll to the event you want to change.
- 3 To edit the time for an event, move the cursor to the line labelled **Time:** and type the desired time.
- 4 To edit a setpoint value, scroll to the setpoint item. Press [**On/Yes**] or [**Off/No**], or enter a numerical value for the setpoint.

Deleting clock time events

- 1 Press [**Clock Table**].
- 2 Use [**Delete**] to remove events from the clock time table. You will be asked to confirm the deletion.
- 3 Press [**On/Yes**] to delete the current timed event; press [**Off/No**] to cancel this operation.

To delete the entire table, press [**Delete**][**Clock Table**].

User-Key Programming

The two User Keys create macros (sets of frequently used keystrokes) and assign them to single keys. A macro is executed when the User Key is pressed.

The stored keystrokes may be any keys except **[Start]**, **[Prog]**, **[User Key 1]**, or **[User Key 2]**.

This discussion assumes that you wish to program **[User Key 1]**. The process is the same for **[User Key 2]**.

To program a User Key

- 1 Press **[Prog]**. Press **[User Key 1]**.
- 2 Press up to 31 keys, then press **[User Key 1]**. The keystrokes are stored.

To play back (execute) the stored keystrokes

Press **[User Key 1]**.

To erase the stored keystrokes

Press **[Prog][User Key 1][User Key 1]**. This creates an “empty” macro.



2 Configuration

About Configuration	23
Assigning GC resources to a device	23
Setting configuration properties	24
General Topics	25
Unlock the GC Configuration	25
Ignore Ready =	25
Information displays	25
Unconfigured:	26
Oven	27
Front Inlet/Back Inlet	29
To configure the PTV or COC coolant	29
To configure the MMI coolant	31
Column #	33
To configure a single column	33
To configure multiple columns	35
Cryo Trap	40
Front Detector/Back Detector/Aux Detector/Aux Detector 2	42
Lit offset	42
To configure the FPD heaters	42
Analog out 1/Analog out 2	43
Fast peaks	43
Valve Box	44
Thermal Aux	45
To configure an MSD transfer line heater	45
To configure a nickel catalyst heater	46
To configure an AED transfer line heater	46
PCM A/PCM B/PCM C	47
Pressure aux 1,2,3/Pressure aux 4,5,6/Pressure aux 7,8,9	49
Status	50
The Ready/Not Ready status table	50
The setpoint status table	50



2 Configuration

Time [51](#)

Valve # [52](#)

Front injector/Back injector [53](#)

Sample tray (7683 ALS) [55](#)

Instrument [56](#)

About Configuration

Configuration is a two- part process for most GC accessory devices that require power and/or communication resources from the GC. In the first part of the configuration process, a power and/or communication resource is assigned to the device. The second part of the configuration process allows setting of any configuration properties associated with the device.

Assigning GC resources to a device

A hardware device requiring but not assigned GC resources is given a mode of **Unconfigured** by the GC. Once you assign GC resources to a device, the GC gives the device a mode of **Configured**, allowing you to access other property settings (if any) for the device.

To assign GC resources to a device with an **Unconfigured** mode:

- 1 Unlock the GC configuration. Press [**Options**], select **Keyboard & Display** and press [**Enter**]. Scroll down to **Hard Configuration Lock** and press [**Off/No**].
- 2 Press [**Config**] on the GC keypad and select a device from the list, then press [**Enter**].

The [**Config**] key opens a menu similar to this:

Oven
Front inlet
Back Inlet
Column #
Front detector
Back detector
Aux detector
Aux detector 2
Analog out 1
Analog out 2
Valve Box
Thermal Aux 1
Thermal Aux 2
Thermal Aux 3
PCM A
PCM B
PCM C
Aux EPC 1,2,3
Aux EPC 4,5,6
Aux EPC 7,8,9

Status
Time
Valve #
2 Dimensional GC Valve
Front injector
Back injector
Sample tray
Instrument

In many cases you can move directly to the item of interest by pressing [**Config**][*device*].

- 3 When the Configure Device Display opens, the cursor should be on the **Unconfigured** field. Press [**Mode/Type**] and follow the GC prompts to assign resources to the device.
- 4 After assigning resources, the GC prompts for you to power cycle the GC. Turn the GC power switch off and then on.

When the GC starts, select the device just assigned the GC resources for further configuration if needed. When accessed, its mode should indicate **Configured** and the other configuration properties are displayed.

Setting configuration properties

A device's configuration properties are constant for an instrument hardware setup unlike method settings which can change from sample run to sample run. An example of a configuration setting is the gas type flowing through a pneumatic device or the operation temperature limit of a device.

To change the setting configuration properties for a **Configured** device:

- 1 Press [**Config**] on the GC keypad and select a device from the list, then press [**Enter**].

In many cases you can move directly to the item of interest by pressing [**Config**][*device*].

- 2 Scroll to the device setting and change the property. This can involve making a selection from a list using [**Mode/Type**], using [**On/Yes**] or [**Off/No**], or entering a numeric value. Press [**Info**] for help on changing numeric settings, or see the section of this document describing the specific configuration of the device.

General Topics

Unlock the GC Configuration

Accessory devices including inlets, detectors, pressure controllers (AUX EPC and PCM), and temperature control loops (Thermal AUX) have electrical connections to a power source and/or the communication bus in the GC. These devices must be assigned GC resources before they can be used. Before assigning resources to a device, you must first unlock the GC configuration. If you try to configure an **Unconfigured** device without unlocking the GC configuration, the GC displays the message **CONFIGURATION IS LOCKED Go to Keyboard options to unlock**.

It is also necessary to unlock the GC configuration if you are removing the GC resources from a **Configured** device. This action returns the device state to **Unconfigured**.

To unlock the GC configuration, press [**Options**], select **Keyboard & Display** and press [**Enter**]. Scroll down to **Hard Configuration Lock** and press [**Off/No**].

The GC configuration remains unlocked until the GC is power cycled off and on.

Ignore Ready =

The states of the various hardware elements are among the factors that determine whether the GC is Ready for analysis.

Under some circumstances, you may not wish to have a specific element readiness considered in the GC readiness determination. This parameter lets you make that choice.

For example, suppose an inlet heater is defective but you don't plan to use that inlet today. By setting **Ignore Ready = TRUE** for that inlet, you can use the rest of the GC. After the heater is repaired, set **Ignore Ready = FALSE** or the run could start before that inlet's conditions are ready.

Information displays

Below are some examples of configuration displays:

[**EPC1**] = (INLET) (SS) EPC #1 is used for an inlet of type split/splitless. It is not available for other uses.

[**EPC3**] = (**DET-EPC**) (**FID**) EPC #3 is controlling detector gases to an FID.

[**EPC6**] = (**AUX_EPC**) (**PCM**) EPC #6 is controlling a two-channel pressure control module.

FINLET (OK) 68 watts 21.7 This heater is connected to the front inlet. Status = OK, meaning that it is ready for use. At the time that the GC was turned on, the heater was drawing 68 watts and the inlet temperature was 21.7 °C.

[**F-DET**] = (**SIGNAL**) (**FID**) The signal board for the front detector is type FID.

AUX 2 1 watts (No sensor) The AUX 2 heater is either not installed or not OK.

Unconfigured:

Accessory devices requiring GC power or communication must be assigned these GC resources before they can be used. To make this hardware element usable, first “[Unlock the GC Configuration](#)” on page 25 then go to the **Unconfigured** parameter and press [**Mode/Type**] to install it. If the hardware element you are configuring requires selection of additional parameters, the GC asks for that selection. If no parameters are required, press [**Enter**] at the GC prompt to install that element. You are required to power the GC off and then power the GC on to complete this configuration.

After restarting the GC, a message reminding you of this change and its effect on the default method is displayed. If needed, change your methods to accommodate the new hardware.

Oven

See “Unconfigured:” on page 26 and “Ignore Ready =” on page 25.

Maximum temperature Sets an upper limit to the oven temperature. Used to prevent accidental damage to columns. The range is 70 to 450 °C.

Equilibration time The time after the oven approaches its setpoint before the oven is declared **Ready**. The range is 0 to 999.99 minutes. Used to ensure that the oven contents have stabilized before starting another run.

Cryo These setpoints control liquid carbon dioxide (CO₂) or liquid nitrogen (N₂) cooling of the oven.

The cryogenic valve lets you operate the oven below ambient temperature. Minimum attainable oven temperature depends on the type of valve installed.

The GC senses the presence and type of cryogenic valve and disallows setpoints if no valve is installed. When cryogenic cooling is not needed or cryogenic coolant is not available, the cryogenic operation should be turned off. If this is not done, proper oven temperature control may not be possible, particularly at temperatures near ambient.

External oven mode Isothermal internal oven and programmed external oven used to calculate column flow.

Slow oven cool down mode On reduces the oven fan speed during the cool down cycle.

To configure the oven

- 1 Press **[Config][Oven]**.
- 2 Scroll to **Maximum temperature**. Enter a value and press **[Enter]**.
- 3 Scroll to **Equilibration time**. Enter a value and press **[Enter]**.
- 4 Scroll to **Cryo**. Press **[On/Yes]** or **[Off/No]**. If **On**, enter the setpoints described in “To configure the oven for cryogenic cooling” on page 28.
- 5 Scroll to **External oven mode**. Press **[On/Yes]** or **[Off/No]**.

- 6 Scroll to **Slow oven cool down mode**. Press [**On/Yes**] to run the oven fan at reduced speed during cool down, or [**Off/No**] to run it at normal speed.

To configure the oven for cryogenic cooling

All cryogenic setpoints are in the [**Config**][**Oven**] parameter list.

Cryo [**ON**] enables cryogenic cooling, [**OFF**] disables it.

Quick cryo cool This feature is separate from **Cryo**. Quick cryo cool makes the oven cool faster after a run than it would without assistance. This feature is useful when maximum sample throughput is necessary, however it does use more coolant. Quick cryo cool turns off soon after the oven reaches its setpoint and **Cryo** takes over, if needed.

Ambient temp The temperature in the laboratory. This setpoint determines the temperature at which cryogenic cooling is enabled:

- Ambient temp + 25°C, for regular cryo operation
- Ambient temp + 45°C, for Quick Cryo Cool.

Cryo timeout **Cryo** timeout occurs, and the oven shuts off, when a run does not start within a specified time (10 to 120 minutes) after the oven equilibrates. Turning **cryo** timeout off disables this feature. We recommend that it be turned on because **cryo** timeout conserves coolant at the end of a sequence or if automation fails.

Cryo fault Shuts the oven down if it does not reach setpoint temperature after 16 minutes of continuous **cryo** operation. Note that this is the time to *reach* the setpoint, not the time to stabilize and become ready at the setpoint. For example, with a cool on- column inlet and **cryo** control in the oven track mode, it may take the oven 20 to 30 minutes to achieve readiness.

If the temperature goes below the minimum allowed temperature (–90°C for liquid nitrogen, –70°C for liquid CO₂), the oven will shut down.

The COC and PTV inlets must use the same **cryo** type as configured for the oven.

Front Inlet/Back Inlet

See “Unconfigured:” on page 26 and “Ignore Ready =” on page 25.

To configure the Gas type

The GC needs to know what carrier gas is being used.

- 1 Press [**Config**][**Front Inlet**] or [**Config**][**Back Inlet**].
- 2 Scroll to **Gas type** and press [**Mode/Type**].
- 3 Scroll to the gas you will use. Press [**Enter**].

This completes carrier gas configuration.

To configure the PTV or COC coolant

Press [**Config**][**Front Inlet**] or [**Config**][**Back Inlet**]. If the inlet has not been configured previously, a list of available coolants is displayed. Scroll to the desired coolant and press [**Enter**]. If oven cooling is installed, your choices are restricted to the coolant used by the oven or **None**.

Cryo type [**Mode/Type**] displays a list of available coolants. Scroll to the desired coolant and press [**Enter**].

If the Cryo type selection is anything other than **None**, several other parameters appear.

Cryo [**On/Yes**] enables cryogenic cooling of the inlet at the specified **Use cryo temperature** setpoint, [**Off/No**] disables cooling.

Use cryo temperature This setpoint determines the temperature at which cryogenic cooling is used continuously. The inlet uses cryogen to achieve the initial setpoint. If the initial setpoint is below the **Use cryo temperature**, cryogen is used continuously to achieve and maintain the setpoint. Once the inlet temperature program starts, the cryogen will be turned off when the inlet exceeds the **Use cryo temperature**. If the initial setpoint is above the **Use cryo temperature**, cryogen is used to cool the inlet until it reaches the setpoint and then it is turned off. At the end of a run, the inlet waits until the oven becomes ready before it uses cryogen.

If the inlet is to be cooled during a run, cryogen will be used to achieve the setpoint. This may have a negative impact on the chromatographic performance of the oven and cause distorted peaks.

Cryo timeout Use this setting to conserve cryogenic fluid. If selected, the instrument shuts down the inlet and cryogenic (subambient) cooling (if installed) when no run starts in the number of minutes specified. The setpoint range is 2 to 120 minutes (default 30 minutes). Turning cryo timeout off disables this feature. We recommend cryo timeout enabling to conserve coolant at the end of a sequence or if automation fails. A Post Sequence method could also be used.

Cryo fault Shuts down the inlet temperature if it does not reach setpoint in 16 minutes of continuous cryo operation. Note that this is the time to *reach* the setpoint, not the time to stabilize and become ready at the setpoint.

Shutdown behavior

Both Cryo timeout and Cryo fault can cause cryo shutdown. If this happens, the inlet heater is turned off and the cryo valve closes. The GC beeps and displays a message.

The inlet heater is monitored to avoid overheating. If the heater remains on at full power for more than 2 minutes, the heater is shut down. The GC beeps and displays a message.

To recover from either condition, turn the GC off, then on, or enter a new setpoint.

To configure the MMI coolant

Press [**Config**][**Front Inlet**] or [**Config**][**Back Inlet**]. If the inlet has not been configured previously, a list of available coolants is displayed. Scroll to the desired coolant and press [**Enter**].

Cryo type/Cooling type [**Mode/Type**] displays a list of available coolants. Scroll to the desired coolant and press [**Enter**]. Normally, select the coolant type that matches the installed hardware.

- **N2 cryo** Select if the N₂ option is installed and you are using LN₂ or compressed air.
- **CO2 cryo** Select if the CO₂ option is installed and you are using LCO₂ or compressed air.
- **Compressed air** Select if the N₂ or CO₂ option is installed and you are only using compressed air. If **Compressed air** is selected as the Cooling type, air coolant is used to cool the inlet regardless of the **Use cryo temperature** setpoint during the cooling cycle. If the inlet reaches setpoint, the air coolant is turned off and stays off for the duration of the cooling cycle. See [Cooling the MMI](#) for more information.

If the Cryo type selection is anything other than **None**, several other parameters appear.

Cryo [**On/Yes**] enables cryogenic cooling of the inlet at the specified **Use cryo temperature** setpoint, [**Off/No**] disables cooling.

Use cryo temperature If **N2 cryo** or **CO2 cryo** is selected as the Cryo type, this setpoint determines the temperature below which cryogenic cooling is used continuously to hold the inlet at setpoint. Set the **Use cryo temperature** equal to or higher than the inlet setpoint to cool the inlet and hold the setpoint until the inlet temperature program exceeds the **Use cryo temperature**. If the **Use cryo temperature** is less than the inlet setpoint, cryogen will cool the inlet to the initial setpoint and turn off.

Cryo timeout This parameter is available with **N2 cryo** and **CO2 cryo** Cryo types. Use this setting to conserve cryogenic fluid. If selected, the instrument shuts down the inlet and cryogenic cooling when no run starts in the number of minutes specified. The setpoint range is 2 to 120 minutes (default 30 minutes). Turning cryo timeout off disables this feature. We recommend cryo timeout enabling to conserve coolant at the end of a sequence or if automation fails. A Post Sequence method could also be used.

Cryo fault This parameter is available with **N2 cryo** and **CO2 cryo** Cryo types. Shuts down the inlet temperature if it does not reach setpoint in 16 minutes of continuous cryo operation. Note that this is the time to *reach* the setpoint, not the time to stabilize and become ready at the setpoint.

Shutdown behavior

Both Cryo timeout and Cryo fault can cause cryo shutdown. If this happens, the inlet heater is turned off and the cryo valve closes. The GC beeps and displays a message.

The inlet heater is monitored to avoid overheating. If the heater remains on at full power for more than 2 minutes, the heater is shut down. The GC beeps and displays a message.

To recover from either condition, turn the GC off, then on, or enter a new setpoint.

Column

Length The length, in meters, of a capillary column. Enter **0** for a packed column or if the length is not known.

Diameter The inside diameter, in millimeters, of a capillary column. Enter **0** for a packed column.

Film thickness The thickness, in millimeters, of the stationary phase for capillary columns.

Inlet Identifies the source of gas for the column.

Outlet Identifies the device into which the column effluent flows.

Thermal zone Identifies the device that controls the temperature of the column.

To configure a single column

You define a capillary column by entering its length, diameter, and film thickness. You then enter the device controlling the pressure at the Inlet (end of the column), the device controlling the pressure at the column Outlet, and the Thermal zone that controls its temperature.

With this information, the instrument can calculate the flow through the column. This has great advantages when using capillary columns because it becomes possible to:

- Enter split ratios directly and have the instrument calculate and set the appropriate flow rates.
- Enter flow rate or head pressure or average linear velocity. The instrument calculates the pressure needed to achieve the flow rate or velocity, sets that, and reports all three values.
- Perform splitless injections with no need to measure gas flows.
- Choose any column mode. If the column is not defined, your choices are limited and vary depending on the inlet.

Except for the simplest configurations, such as a column connected to a specific inlet and detector, we recommend that you begin by making a sketch of how the column will be connected.

- 1 Press [**Config**][**Col 1**] or [**Config**][**Col 2**], or press [**Config**][**Aux Col #**] and enter the number of the column to be configured.
- 2 Scroll to the **Length** line, type the column length, in meters, followed by [**Enter**].
- 3 Scroll to **Diameter**, type the column inside diameter in microns, followed by [**Enter**].
- 4 Scroll to **Film thickness**, type the film thickness in microns, followed by [**Enter**]. The column is now *defined*.

If you do not know the column dimensions—they are usually supplied with the column—or if you do not wish to use the GC calculating features, enter **0** for either **Length** or **Diameter**. The column will be *not defined*.

- 5 Scroll to **Inlet**. Press [**Mode/Type**] to select a gas pressure control device for this end of the column. Selections include the installed GC inlets, and installed Aux and PCM channels.

Select the appropriate gas pressure control device and press [**Enter**].

- 6 Scroll to **Outlet**. Press [**Mode/Type**] to select a gas pressure control device for this end of the column. Selections include the installed Aux and PCM channels, and detectors. When a detector is selected, the outlet end of the column is controlled at 0 psig for the FID, TCD, FPD, NPD, and uECD or vacuum for the MSD.

Select the appropriate gas pressure control device and press [**Enter**].

- 7 Scroll to **Thermal zone**. Press [**Mode/Type**] to see the available choices. In most cases this will be **GC oven**, but you may have an MSD transfer line heated by an auxiliary zone, valves in a separately- heated valve box or other configurations.

Select the appropriate **Thermal zone** and press [**Enter**].

This completes configuration for a single capillary column.

Additional notes on column configuration

Packed columns should be configured as column not defined. To do this, enter **0** for either column length or column diameter.

You should check configurations for all columns to verify that they specify the correct pressure control device at each end. The GC uses this information to determine the flow path of the carrier gas. Only configure columns that are in current use in your GC's carrier gas flow path. Unused columns configured with the same pressure control device as a column in the current flow path cause incorrect flow results.

It is possible, and sometimes appropriate, to configure both installed columns to the same inlet.

When splitters or unions exist in the carrier gas flow path, without a GC's pressure control device monitoring the common junction point, the individual column flows cannot be controlled directly by the GC. The GC can only control the inlet pressure of the upstream column whose inlet end is attached to a GC's pressure control device. A column flow calculator available from Agilent, and provided with Agilent capillary flow devices, is used for determining pressures and flows at this type of junction.

Some pneumatic setpoints change with oven temperature because of changes in column resistance and in gas viscosity. This may confuse users who observe pneumatics setpoints changing when their oven temperature changes. However, the flow condition in the column remains as specified by the column mode (constant flow or pressure, ramped flow or pressure) and the initial setpoint values.

To configure multiple columns

To configure multiple columns, repeat the procedure above for each column.

These are the available choices for **Inlet**, **Outlet**, and **Thermal zone**. Some will not appear on your GC if the specific hardware is not installed.

Table 1 Choices for column configuration

Inlet	Outlet	Thermal zone
Front inlet	Front detector	GC oven
Back inlet	Back detector	Auxiliary oven
Aux# 1 through 9	MSD	Aux thermal zone 1
PCM A, B, and C	Aux detector	Aux thermal zone 2
Aux PCM A, B, and C	Aux 1 through 9	

Table 1 Choices for column configuration (continued)

Inlet	Outlet	Thermal zone
Unspecified	PCM A, B, and C	
	Aux PCM A, B, and C	
	Front inlet	
	Back inlet	
	Other	

Inlets and outlets

The pressure control devices at the inlet and outlet ends of a column, or series of columns in a flow path, control its gas flow. The pressure control device is physically attached to the column through a connection to a GC inlet, a valve, a splitter, a union, or other device.

Table 2 Column inlet end

If the column gas flow source is:	Choose:
An inlet (SS, PP, COC, MMI, PTV, VI, or other) with electronic pressure control	The inlet.
A valve, such as gas sampling	The auxiliary (Aux PCM) or pneumatics (PCM) control module channel that provides gas flow during the inject cycle.
A splitter with an EPC makeup gas supply	The Aux PCM or EPC channel that provides the makeup gas
A device with a manual pressure controller	Unknown

Similar considerations apply for the column outlet end. When a column exits to a splitter, select the GC’s pressure control source attached to the same splitter.

Table 3 Column outlet end

If the column exhausts into	Choose:
A detector	The detector.
A splitter with a makeup gas supply	The Aux PCM or EPC channel that provides makeup gas flow to the splitter.
A device with a manual pressure controller	Unknown

A simple example

An analytical column is attached at its inlet end to a split/splitless inlet located at the front of the GC and the column outlet is attached to an FID located at the front detector position.

Table 4 Analytical column

Column	Inlet	Outlet	Thermal zone
Analytical column	Front split/splitless	Front FID	GC oven

Since only a single column is configured, the GC determines that it controls the inlet pressure to the column by setting the front inlet pressure and the outlet pressure is always atmospheric. The GC can calculate a pressure for the front inlet that can exactly overcome the resistance to flow presented by this column at any point during a run.

Slightly more complex example

A precolumn is followed by a AUX 1 pressure controlled splitter and two analytical columns. This requires three column descriptions.

Table 5 Precolumn split to two analytical columns

Column	Inlet	Outlet	Thermal zone
1 - Precolumn	Front inlet	AUX 1	GC oven
2 - Analytical column	AUX 1	Front detector	GC oven
3 - Analytical column	AUX 1	Back detector	GC oven

The GC can calculate the flow through the precolumn using the precolumn's physical properties to calculate the column's resistance to flow, along with the front inlet pressure and the AUX 1 pressure. Your analytical method can set this flow directly for the precolumn.

For the flow in the two parallel analytical columns 1 and 2, the GC can use the column's physical properties to calculate the split flow through each individual column, at a given AUX 1 pressure, with both columns exiting to atmospheric pressure. Your analytical method can only set the flow for the lowest numbered column in a split, analytical column 2. If you try to set the flow for column #3, it will be ignored and the flow for column #2 will be used.

If other columns are currently defined, they may not use AUX 1, Front inlet, Front detector, or Back detector in their configuration.

Complicated example

The inlet feeds the analytical column which ends at a three-way splitter. The splitter has the column effluent and makeup gas coming in, and transfer lines (non-coated columns) to three different detectors. This is a case where a sketch is necessary.

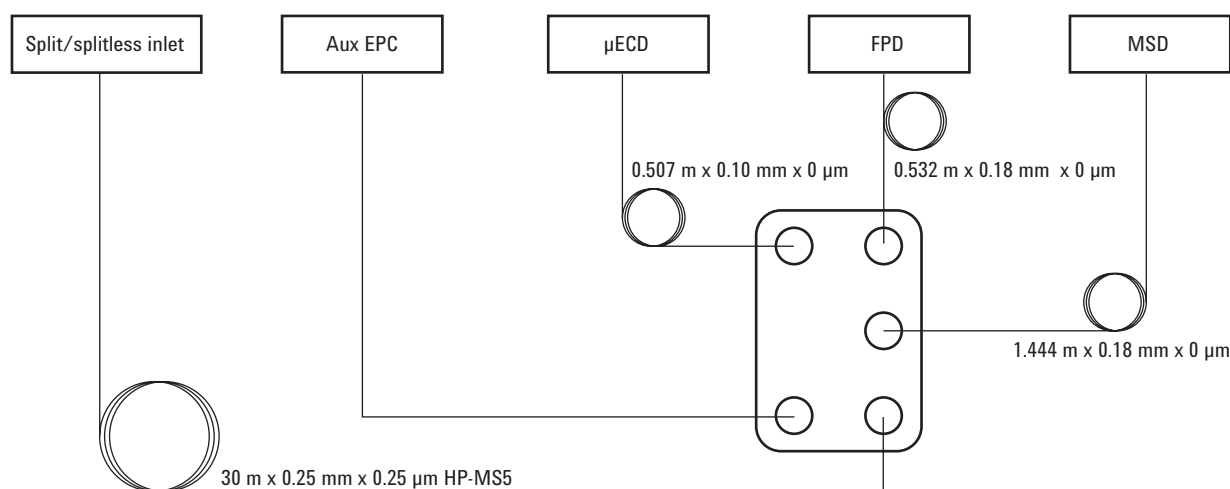

Table 6 Splitter with makeup and multiple detectors

Column	Inlet	Outlet	Thermal zone
1 - 30 m × 0.25 mm × 0.25 μm	Front inlet	Aux PCM 1	GC oven
2 - 1.444 m × 0.18 mm × 0 μm	Aux PCM 1	MSD	GC oven
3 - 0.507 m × 0.10 mm × 0 μm	Aux PCM 1	Front detector	GC oven
4 - 0.532 m × 0.18 mm × 0 μm	Aux PCM 1	Back detector	GC oven

The oven was chosen for the MSD line since most of it is in the oven.

As in the previous examples, your analytical method can control the flow of column # 1 which has a GC pressure controlled inlet and outlet.

The flows to the three detectors are based on the pressure drops through the capillaries and their resistance to flow. An Agilent flow calculator provided with the capillary flow splitter device is used to size the length and diameter of these capillary sections to obtain the desired split ratios.

Your analytical method can set the flow or pressure for column # 2, the lowest numbered column in the split. Use the value obtained from the Agilent flow calculator for this setpoint in your method.

Cryo Trap

This discussion assumes that the trap is mounted in position B, that you use liquid nitrogen coolant and control the trap with Thermal Aux 1.

Configuration is in several parts:

- Configure the trap to the GC
- Configure a heater to the cryo trap.
- Configure the coolant.
- Configure the user- configurable heater.
- Reboot the GC.

Configure the cryo trap to the GC

- 1 Press [**Config**], then [**Aux Temp #**] and select **Thermal Aux 1**. Press [**Enter**].
- 2 Press [**Mode/Type**]. Scroll to **Install BINLET with BV Cryo** and press [**Enter**].
- 3 Press [**Options**], select **Communications**, and press [**Enter**]. Select **Reboot GC** and press [**On/Yes**] twice.

This informs the GC that a cryo trap is installed at position B.

Configure a heater to the cryo trap

- 1 Press [**Config**], then [**Aux Temp #**], select **Thermal Aux 1** and press [**Enter**]. Select **Auxiliary Type: Unknown** and press [**Mode/Type**]. Select **User Configurable Heater** and press [**Enter**].
- 2 Press [**Options**], select **Communications**, and press [**Enter**]. Select **Reboot GC** and press [**On/Yes**] twice.

This informs the GC that the heater parameters will be supplied by the user.

Configure the coolant

The GC can handle only one type of coolant. If the coolant has already been specified for some other device, then that same coolant must be specified here.

- 1 Press [**Config**], then [**Aux Temp #**].
- 2 Select **Thermal Aux 1** and press [**Enter**].
- 3 Scroll to **Cryo Type (Valve BV)**.

If the value is *not* **N2**, press [**Mode/Type**], select **N2 Cryo**, press [**Enter**] and then [**Clear**].

This tells the GC what coolant will be used.

Configure the user-configurable heater

Many of the following steps tell you to reboot the GC. Ignore these requests by pressing [**Clear**]. Do *not* reboot until specifically told to do so in these instructions.

- 1 Press [**Config**] and select **Aux 1**. Press [**Enter**].
- 2 Enter the following control values. Press [**Enter**], then [**Clear**] after each one.
 - a Proportional Gain—5.30
 - b Integral Time—10
 - c Derivative Time—1.00
 - d Mass (Watt- sec/deg)—18
 - e Power (Watts)—To find the watts to set here, scroll to **Back Inlet Status (BINLET)**. Note the watts value and enter it for this parameter.
 - f Cryo Control Mode—Press [**Mode/Type**]. The first line should already be **PTV**. Select **Cryo Trap**.
 - g Zone Control mode—Press [**Mode/Type**] and select **PTV**.
 - h Sensor—Press [**Mode/Type**] and select **Thermocouple**.
 - i Maximum Setpoint—400
 - j Maximum Programming Rate—720

Reboot the GC

Press [**Options**], select **Communications**, and press [**Enter**]. Select **Reboot GC** and press [**On/Yes**] twice.

Front Detector/Back Detector/Aux Detector/Aux Detector 2

See [Ignore Ready =](#) and [“Unconfigured:”](#) on page 26.

To configure the makeup/reference gas

The makeup gas line of your detector parameter list changes depending on your instrument configuration.

If you have an inlet with the *column not defined*, the makeup flow is constant. If you are operating with *column defined*, you have a choice of two makeup gas modes. See [“About Makeup Gas”](#) on page 298 for details.

- 1 Press **[Config]**[*device*], where [*device*] is one of the following:
 - **[Front Det]**
 - **[Back Det]**
 - **[Aux detector 1]**
 - **[Aux detector 2]**
- 2 Scroll to **Makeup gas type** (or **Makeup/reference gas type**) and press **[Mode/Type]**.
- 3 Scroll to the correct gas and press **[Enter]**.

Lit offset

The GC monitors the difference between the detector output with the flame lit and the output when the flame is not lit. If this difference falls below the setpoint, the GC assumes that the flame has gone out and tries to reignite it. See [“FID automatic reignition \(Lit offset\)”](#) on page 301 for details.

To configure the FPD heaters

The flame photometric detector (FPD) uses two heaters, one in the base and one near the combustion chamber. When configuring the FPD heaters, select **Install Detector 2 htr** rather than the default **Install Detector (FPD)**.

Analog out 1/Analog out 2

Fast peaks

The GC allows you to output analog data at two speeds. The faster speed—to be used only with the FID, FPD, and NPD—allows minimum peak widths of 0.004 minutes (8 Hz bandwidth), while the standard speed—which can be used with all detectors—allows minimum peak widths of 0.01 minutes (3.0 Hz bandwidth).

To use fast peaks:

- 1 Press [**Config**][**Analog out 1**] or [**Config**][**Analog out 2**].
- 2 Scroll to **Fast peaks** and press [**On/Yes**].

The *fast peaks* feature does not apply to digital output.

If you are using the *fast peaks* feature, your integrator must be fast enough to process data coming from the GC. Integrator bandwidth should be at least 15 Hz.

Valve Box

See “Unconfigured:” on page 26 and “Ignore Ready =” on page 25.

The valve box mounts on top of the column oven. It may contain up to four valves mounted on heated blocks. Each block can accommodate two valves.

Valve positions on the blocks are numbered. We suggest that valves be installed in the blocks in numeric order.

All heated valves in a valve box are controlled by the same temperature setpoint.

To assign a GC power source to a valve box heater

- 1 Unlock the GC configuration, press the [**Options**] key, select **Keyboard & Display** and press the [**Enter**] key. Scroll down to **Hard Configuration Lock** and press the [**off**] button.
- 2 Press [**Config**], scroll to **Valve Box** and press [**Enter**].
- 3 With **Unconfigured** selected, press [**Mode/type**], select one of the following and press [**Enter**].
 - **Install heater A1** - for a valve box containing a single heater plugged into the connector labeled A1 on the valve box bracket.
 - **Install Heater A2** - for a valve box containing a single heater plugged into the connector labeled A2 on the valve box bracket.
 - **Install 2 htr A1 & A2** - for a valve box containing two heaters plugged into the connectors labeled A1 and A2 on the valve box bracket.

The valve box bracket is located inside the GC right side electrical compartment in the upper right location.

- 4 When prompted by the GC, turn the power off then on again.

This completes the configuration of the valve box. To set the valve box temperature for your method press the [**valve #**] key, and scroll to **Valve Box**.

Thermal Aux

See “Unconfigured:” on page 26 and “Ignore Ready =” on page 25.

The auxiliary thermal controllers provide up to three channels of temperature control. These controllers are labeled Thermal Aux 1, Thermal Aux 2, and Thermal Aux 3.

To assign a GC power source to an Aux thermal zone

This procedure assigns a the heater power source from heater plug A1 or A2 to Thermal Aux 1, Thermal Aux 2, or Thermal Aux 3 temperature control zones.

- 1 Unlock the GC configuration, press [**Options**], select **Keyboard & Display** and press [**Enter**]. Scroll down to **Hard Configuration Lock** and press [**Off/No**].
- 2 Press [**Config**][**Aux Temp #**] and scroll to **Thermal Aux 1, Thermal Aux 2, or Thermal Aux 3** and press [**Enter**].
- 3 With **Unconfigured** selected, press [**Mode/Type**], and select:
 - **Install Heater A1** if the heated device is plugged into the valve box bracket plug labeled A1.
 - **Install Heater A2** if the heated device is plugged into the valve box bracket plug labeled A2.
- 4 Press [**Enter**] after making selection.
- 5 When prompted by the GC, turn the power off then on again.

To configure an MSD transfer line heater

- 1 Check that a power source for the MSD heater was assigned. See “To assign a GC power source to an Aux thermal zone” on page 45.
- 2 Press [**Config**][**Aux Temp #**] and scroll to **Thermal Aux 1, Thermal Aux 2, or Thermal Aux 3** depending on where the MSD heater was assigned, and press [**Enter**].
- 3 Scroll to **Auxiliary type**, press [**Mode/Type**], scroll to and select the **MSD transfer line**, and press [**Enter**].

To configure a nickel catalyst heater

- 1 Check that a power source for the Nickel Catalyst heater was assigned. See [“To assign a GC power source to an Aux thermal zone”](#) on page 45.
- 2 Press **[Config][Aux Temp #]** and scroll to **Thermal Aux 1, Thermal Aux 2, or Thermal Aux 3** depending on where the Nickel Catalyst heater was assigned, and press **[Enter]**.
- 3 Scroll to **Auxiliary type**, press **[Mode/Type]**, scroll to and select **Nickel catalyst**, and press **[Enter]**.

To configure an AED transfer line heater

- 1 Check that a power source for the AED transfer line heater was assigned. See [“To assign a GC power source to an Aux thermal zone”](#) on page 45.
- 2 Press **[Config][Aux Temp #]** and scroll to **Thermal Aux 1, Thermal Aux 2, or Thermal Aux 3** depending on where the AED transfer line heater was assigned, and press **[Enter]**.
- 3 Scroll to **Auxiliary type**, press **[Mode/Type]**, scroll to and select the **AED transfer line**, and press **[Enter]**.

PCM A/PCM B/PCM C

See “Unconfigured:” on page 26 and “Ignore Ready =” on page 25.

A pressure control module (PCM) provides two channels of gas control.

Channel 1 is a simple forward- pressure regulator that maintains a constant pressure at its output. With a fixed downstream restrictor, it provides constant flow.

Channel 2 is more versatile. With the normal flow direction (in at the threaded connector, out via the coiled tubing), it is similar to channel 1. However with the flow direction reversed (some extra fittings will be needed), it becomes a back- pressure regulator that maintains a constant pressure at its inlet.

Thus channel 2 (reversed) behaves as a controlled leak. If the inlet pressure drops below setpoint, the regulator closes down. If inlet pressure rises above setpoint, the regulator bleeds off gas until the pressure returns to setpoint.

To assign a GC communication source to a PCM

- 1 Unlock the GC configuration, press [**Options**], select **Keyboard & Display** and press [**Enter**]. Scroll down to **Hard Configuration Lock** and press [**Off/No**].
- 2 Press [**Config**][**Aux EPC #**], scroll to a **PCMx** and press [**Enter**].
- 3 With **Unconfigured** selected, press [**Mode/Type**], select **Install EPCx** and press [**Enter**].
- 4 When prompted by the GC, turn the power off then on again.

To configure the other parameters on this PCM, see [To configure a PCM](#).

To configure a PCM

- 1 Press [**Config**][**Aux EPC #**], scroll to the **PCMx** and press [**Enter**].
- 2 Scroll to **Gas type**, press [**Mode/Type**], make a selection and press [**Enter**].

This completes configuration for Channel 1. The rest of the entries refer to Channel 2.

- 3 Scroll to **Aux gas type**, press [**Mode/Type**], make a selection and press [**Enter**].

4 Scroll to **Aux Mode:**, press [**Mode/Type**], select one of the following and press [**Enter**]:

- Forward Pressure Control - Aux channel
- Back Pressure Control- Aux channel

For a definition of these terms see “[Pressure Control Modules](#)” on page 158.

The pressure control mode for the main channel is set by pressing [**Aux EPC #**]. Select **Mode:** , press [**Mode/Type**], select the mode and press [**Enter**].

Pressure aux 1,2,3/Pressure aux 4,5,6/Pressure aux 7,8,9

See [Ignore Ready =](#) and [“Unconfigured:”](#) on page 26.

An auxiliary pressure controller provides three channels of forward- pressure regulation. Three modules can be installed for a total of nine channels.

The numbering of the channels depends on where the controller is installed. See [“Auxiliary Pressure Controllers”](#) on page 161 for details. Within a single module, channels are numbered from left to right (as seen from the back of the GC) and are labeled on the AUX EPC module.

To assign a GC communication source to an Aux EPC

- 1 Unlock the GC configuration, press [**Options**], select **Keyboard & Display** and press [**Enter**]. Scroll down to **Hard Configuration Lock** and press [**Off/No**].
- 2 Press [**Config**][**Aux EPC #**], select **Aux EPC 1,2,3** or **Aux EPC 4,5,6** or **Aux EPC 7,8,9** and press [**Enter**].
- 3 With **Unconfigured** selected, press [**Mode/Type**], select **Install EPCx** and press [**Enter**].
- 4 When prompted by the GC, turn the power off then on again.

To configure the other parameters on this EPC, see [To configure an auxiliary pressure channel](#).

To configure an auxiliary pressure channel

- 1 Press [**Config**][**Aux EPC #**], select **Aux EPC 1,2,3** or **Aux EPC 4,5,6** or **Aux EPC 7,8,9** and press [**Enter**].
- 2 Select **Chan x Gas type**, press [**Mode/Type**], select the gas that is plumbed to the channel and press [**Enter**].
- 3 If necessary, repeat the above step for the other two channels on this EPC module.

Status

The **[Status]** key has two tables associated with it. You switch between them by pressing the key.

The Ready/Not Ready status table

This table lists parameters that are *Not Ready* or gives you a *Ready for Injection* display. If there are any *faults*, *warnings*, or *method mismatches* present, they are displayed here.

The setpoint status table

This table lists setpoints compiled from the active parameter lists on the instrument. This is a quick way to view active setpoints during a run without having to open multiple lists.

To configure the setpoint status table

You can change the order of the list. You might want the three most important setpoints to appear in the window when you open the table.

- 1 Press **[Config][Status]**.
- 2 Scroll to the setpoint that should appear first and press **[Enter]**. This setpoint will now appear at the top of the list.
- 3 Scroll to the setpoint that should appear second and press **[Enter]**. This setpoint will now be the second item on the list.
- 4 And so on, until the list is in the order you wish.

Time

Press [**Time**] to open this function. The first line always displays the current date and time, and the last line always displays a stopwatch. The two middle lines vary:

Between runs Show last and next (calculated) run times.

During a run Show time elapsed and time remaining in the run.

During Post Run Show last run time and remaining Post Run time.

To set time and date

- 1 Press [**Config**][**Time**].
- 2 Select **Time zone (hhmm)** and enter the local time offset from GMT using a 24 hour format.
- 3 Select **Time (hhmm)** and enter the local time.
- 4 Select **Date (ddmmyy)** and enter the date.

To use the stopwatch

- 1 Press [**Time**].
- 2 Scroll to the **time=** line.
- 3 To begin the timed period press [**Enter**].
- 4 To stop the timed period press [**Enter**].
- 5 Press [**Clear**] to reset the stopwatch.

Valve

Up to 4 valves can be mounted in a temperature- controlled valve box and are normally wired to the valve box bracket V1 through V4 plugs, located inside the electrical compartment. Additional valves or other devices (4 through 8) can be wired using the plug labeled **EVENT** on the back of the GC.

To configure a valve

- 1 Press **[Config][Valve #]** and enter the number (1 to 8) of the valve you are configuring. The current valve type is displayed.
- 2 To change the valve type, press **[Mode/Type]**, select the new valve type, and press **[Enter]**.

Valve types

- **Sampling** Two- position (load and inject) valve. In load position, an external sample stream flows through an attached (gas sampling) or internal (liquid sampling) loop and out to waste. In inject position, the filled sampling loop is inserted into the carrier gas stream. When the valve switches from Load to Inject, a run starts if one is not already in progress. See the example in [“Gas sampling valve”](#) on page 346.
- **Switching** Two- position valve with four, six, or more ports. These are general- purpose valves used for such tasks as column selection, column isolation, and many others. For an example of valve control, see [“Simple valve: column selection”](#) on page 345.
- **Multiposition** Also called a stream selection valve. It selects one from a number of gas streams and feeds it to a sampling valve. The actuator may be ratchet- (advances the valve one position each time it is activated) or motor- driven. An example that combines a stream selection valve with a gas sampling valve is on [page 347](#).
- **Remote start** Available selection when configuring valve #7 or #8 only. Use this selection when wires controlling an external device are attached to an internal pair of contacts controlled by the GC.
- **Other** Something else.
- **Not installed** Self- explanatory.

Front injector/Back injector

The GC supports two models of samplers.

For the 7693A samplers, the GC recognizes which injector is plugged into which connector, **INJ1** or **INJ2**. No configuration is needed. To move an injector from one inlet to another requires no settings: the GC detects the injector position.

To configure the 7693A sampler system, see the [7693A Installation, Operation, and Maintenance manual](#).

For the 7683 series samplers, normally the front inlet's injector is plugged into the connection on the rear of the GC labeled **INJ1**. The rear inlet's injector is plugged into the connection on the rear of the GC labeled **INJ2**.

When a GC shares a single 7683 injector between two inlets, the injector is moved from one inlet to the other and the injector's plug-in on the rear of the GC is switched.

To move the 7683 injector from one inlet on the GC to another without changing the injector's plug-in, use the **Front/Back tower** parameter.

Solvent Wash Mode (7683 ALS)

This section applies to the 7683 ALS system. To configure the 7693A sampler system, see the [7693A Installation, Operation, and Maintenance manual](#).

Depending upon the installed injector and turret, these parameters may be available to configure multiple solvent wash bottles usage. If necessary, refer to your injector user documentation for details.

A, B—Use solvent bottle A if injector uses solvent A washes and solvent bottle B if injector uses solvent B washes.

A-A2, B-B2—Use solvent bottles A and A2 if injector uses solvent A washes and solvent bottles B and B2 if injector uses solvent B washes. The injector alternates between both bottles.

A-A3, B-B3—Use solvent bottles A, A2, and A3 if injector uses solvent A washes and solvent bottles B, B2, and B3 if injector uses solvent B washes. The injector alternates between all bottles.

To configure an injector (7683 ALS)

This section applies to the 7683 ALS system. To configure the 7693A sampler system, see the [7693A Installation, Operation, and Maintenance manual](#).

- 1 Press [**Config**][**Front Injector**] or [**Config**][**Back Injector**].
- 2 Scroll to **Front/Back tower**.
- 3 Press [**Off/No**] to change the present tower position from INJ1 to INJ2 or from INJ2 to INJ1.
- 4 If the installed turret has locations for multiple solvent bottles, scroll to **Wash Mode**, press [**Mode/Type**], and then select **1**, **2**, or **3** bottles for each solvent and press [**Enter**].
- 5 Scroll to [**Syringe size**]. Enter the size of the syringe that is installed and press [**Enter**].

Sample tray (7683 ALS)

This section applies to the 7683 ALS system. To configure the 7693A sampler system, see the [7693A Installation, Operation, and Maintenance manual](#).

- 1 Press [**Config**][**Sample Tray**].
- 2 If the vial gripper is touching vials either too high or too low for reliable pickup, scroll to **Grip offset** and press [**Mode/Type**] to select:
 - **Up** to increase the gripper arm pickup height
 - **Default**
 - **Down** to decrease the gripper arm pickup height
- 3 Scroll to **Bar Code Reader**.
- 4 Press [**On/Yes**] or [**Off/No**] to control the following bar code setpoints:
 - **Enable 3 of 9**—encodes both letters and numbers, plus a few punctuation marks, and message length can be varied to suit both the amount of data to be encoded and the space available
 - **Enable 2 of 5**—restricted to numbers but does allow variable message length
 - **Enable UPC code**—restricted to numbers- only with fixed message length
 - **Enable checksum**—verifies that the checksum in the message matches the checksum calculated from the message characters, but does not include the checksum character in the returned message
- 5 Enter **3** as the **BCR Position** when the reader is installed in the front of the tray. Positions 1–19 are available.

Instrument

- 1 Press [**Config**]. Scroll to **Instrument** and press [**Enter**].
- 2 Scroll to **Serial #**. Enter a serial number and press [**Enter**].
This function can only be done by Agilent service personnel.
- 3 Scroll to **Auto prep run**. Press [**On/Yes**] to enable **Auto prep run**, [**Off/No**] to disable it. See “[Pre Run and Prep Run](#)” on page 171 for details.
- 4 Scroll to **Zero Init Data Files**.
 - Press [**On/Yes**] to enable it. When it is On, the GC immediately begins to subtract the current detector output from all future values. This applies only to digital output, and is useful when a non-Agilent data system has problems with baseline data that is non-zero.
 - Press [**Off/No**] to disable it. This is appropriate for all Agilent data systems.
- 5 **Front inlet type:** and **Back inlet type:** are both information displays. The values are determined by the type of flow modules installed.
- 6 The **Oven** line displays the GC power configuration.
- 7 Press [**Clear**] to return to the **Config** menu or any other function to end.



3 Options

About Options 58

Calibration 59

Maintaining EPC calibration—inlets, detectors, PCM, and AUX 59

Auto zero septum purge 60

Auto flow zero 59

Zero conditions 60

Zero intervals 60

To zero a specific flow or pressure sensor 60

To zero all pressure sensors in all modules 61

Column calibration 61

Communication 65

Configuring the IP address for the GC 65

Keyboard and Display 66



About Options

The **[Options]** key is used for a group of functions that are usually set on installation and seldom changed afterward. It accesses this menu:

Calibration

Communication

Keyboard and Display

Calibration

Press [Calibration] to list the parameters that can be calibrated. These include:

- Inlets
- Detectors
- ALS
- Columns
- Oven
- Atmospheric pressure

In general, you will only need to calibrate the EPC modules and capillary columns. ALS, oven, and atmospheric pressure calibration should only be performed by trained service personnel.

The calibration displays are discussed in the Agilent 7890A Service Manual.

Maintaining EPC calibration—inlets, detectors, PCM, and AUX

The EPC gas control modules contain flow and/or pressure sensors that are calibrated at the factory. Sensitivity (slope of the curve) is quite stable, but zero offset requires periodic updating.

Flow sensors

The split/splitless and purged packed inlet modules use flow sensors. If the **Auto flow zero** feature (see [page 59](#)) is on, they are zeroed automatically after each run. This is the recommended way. They can also be zeroed manually—see [“To zero a specific flow or pressure sensor.”](#)

Pressure sensors

All EPC control modules use pressure sensors. They can be zeroed as a group or individually. There is no automatic zero for pressure sensors.

Auto flow zero

A useful calibration option is **Auto flow zero**. When it is **On**, after the end of a run the GC shuts down the flow of gases to an inlet, waits for the flow to drop to zero, measures and stores the flow

sensor output, and turns the gas back on. This takes about two seconds. The zero offset is used to correct future flow measurements.

To activate this, select **Calibration** on the **Options** menu, then choose either **Front inlet** or **Back inlet**, press **[Enter]**, and turn **Auto flow zero** on.

Auto zero septum purge

This is similar to **Auto flow zero**, but is for the septum purge flow.

Zero conditions

Flow sensors are zeroed with the carrier gas connected and flowing.

Pressure sensors are zeroed with the supply gas line disconnected from the gas control module.

Zero intervals

Table 7 Flow and Pressure Sensor Zero Intervals

Sensor type	Module type	Zero interval
Flow	All	Use Auto flow zero and/or Auto zero septum purge
Pressure	Inlets	
	Packed columns	Every 12 months
	Small capillary columns (id 0.32 mm or less)	Every 12 months
	Large capillary columns (id > 0.32 mm)	At 3 months, at 6 months, then every 12 months
	Auxiliary channels	Every 12 months
	Detector gases	Every 12 months

To zero a specific flow or pressure sensor

- 1 Press **[Options]**, scroll to **Calibration**, and press **[Enter]**.
- 2 Scroll to the module to be zeroed and press **[Enter]**.
- 3 Scroll to a zero line and press **[Info]**. The GC will remind you of the conditions necessary for zeroing that specific sensor.

Flow sensors. Verify that the gas is connected and flowing (turned on).

Pressure sensors. Disconnect the gas supply line at the back of the GC. Turning it off is not adequate; the valve may leak.

- 4 Press [**On/Yes**] to zero or [**Clear**] to cancel.

To zero all pressure sensors in all modules

- 1 Press [**Service Mode**], scroll to **Diagnostics**, and press [**Enter**].
- 2 Scroll to **Electronics** and press [**Enter**].
- 3 Scroll to **Pneumatics** and press [**Enter**].
- 4 Scroll to **Zero all pressure sensors** and press [**Info**]. The GC will remind you that all gas supplies must be disconnected at the back panel. Turning them off is not adequate; the valves may leak.
- 5 Press [**On/Yes**] to zero or [**Clear**] to cancel.

Column calibration

As you use a capillary column, you may occasionally trim off portions, changing the column length. If measuring the actual length is impractical, and if you are using EPC with a defined column, you can use an internal calibration routine to estimate the actual column length. Similarly, if you do not know the column internal diameter or believe it is inaccurate, you can estimate the diameter from related measurements.

Before you can calibrate the column, make sure that:

- You are using a capillary column
- The column is defined
- There are no oven ramps
- The column gas source (usually the inlet) is **On** and non-zero

Also note that column calibration fails if the calculated column length correction is ≥ 5 m, or if the calculated diameter correction is ≥ 20 μm .

Calibration modes

There are three ways to calibrate the column length and/or diameter:

- Calibrate using an actual measured column flow rate
- Calibrate using an unretained peak time (elution time)
- Calibrate both length and diameter using flow rate and elution time

CAUTION

When you measure the column flow rate, be sure to convert the measurement to normal temperature and pressure if your measurement device does not report data at NTP. If you enter uncorrected data, the calibration will be wrong.

To estimate the actual column length or diameter from an elution time

- 1 Set oven ramp 1 to 0.00, then verify that the column is defined.
- 2 Perform a run using an unretained compound and record the elution time.
- 3 Press [**Options**], scroll to **Calibration** and press [**Enter**].
- 4 From the calibration list, select the column and press [**Enter**]. The GC displays the current calibration mode for the column.
- 5 To recalibrate or to change calibration mode, press [**Mode/Type**] to see the column calibration mode menu.
- 6 Scroll to **Length** or **Diameter** and press [**Enter**]. The following choices appear:
 - **Mode**
 - **Measured flow**
 - **Unretained peak**
 - **Calculated length** or **Calculated diameter**
 - **Not calibrated**
- 7 Scroll to **Unretained peak** and enter the actual elution time from the run performed above.
- 8 When you press [**Enter**], the GC will estimate the column length or diameter based on the elution time input and will now use that data for all calculations.

To estimate the actual column length or diameter from the measured flow rate

- 1 Set oven ramp 1 to 0.00, then verify that the column is defined.
- 2 Set the oven, inlet, and detectors temperatures to 35 °C and allow them to cool to room temperature.
- 3 Remove the column from the detector.

CAUTION

When you measure the column flow rate, be sure to convert the measurement to normal temperature and pressure if your measurement device does not report data at NTP. If you enter uncorrected data, the calibration will be wrong.

- 4 Measure the actual flow rate through the column using a bubble meter. Record the value. Reinstall the column.
- 5 Press **[Options]**, scroll to **Calibration** and press **[Enter]**.
- 6 From the calibration list, select the column and press **[Enter]**. The GC displays the current calibration mode for the column.
- 7 To recalibrate or to change calibration mode, press **[Mode/Type]** to see the column calibration mode menu.
- 8 Scroll to **Length** or **Diameter** and press **[Enter]**. The following choices appear:
 - **Mode**
 - **Measured flow**
 - **Unretained peak**
 - **Calculated length** or **Calculated diameter**
 - **Not calibrated**
- 9 Scroll to **Measured flow** and enter the corrected column flow rate (in mL • min) from the run performed above.
- 10 When you press **[Enter]**, the GC will estimate the column length or diameter based on the elution time input and will now use that data for all calculations.

To estimate the actual column length and diameter

- 1 Set oven ramp 1 to 0.00, then verify that the column is defined.
- 2 Perform a run using an unretained compound and record the elution time.
- 3 Set the oven, inlet, and detectors temperatures to 35 °C and allow them to cool to room temperature.
- 4 Remove the column from the detector.

CAUTION

When you measure the column flow rate, be sure to convert the measurement to normal temperature and pressure if your measurement device does not report data at NTP. If you enter uncorrected data, the calibration will be wrong.

- 5 Measure the actual flow rate through the column using a bubble meter. Record the value. Reinstall the column.
- 6 Press [**Options**], scroll to **Calibration** and press [**Enter**].
- 7 From the calibration list, select the column and press [**Enter**]. The GC displays the current calibration mode for the column.
- 8 To recalibrate or to change calibration mode, press [**Mode/Type**] to see the column calibration mode menu.
- 9 Scroll to **Length & diameter** and press [**Enter**]. The following choices appear:
 - **Mode**
 - **Measured flow**
 - **Unretained peak**
 - **Calculated length**
 - **Calculated diameter**
 - **Not calibrated**
- 10 Scroll to **Measured flow** and enter the corrected column flow rate (in mL •min) from the run performed above.
- 11 Scroll to **Unretained peak** and enter the actual elution time from the run performed above.
- 12 When you press [**Enter**], the GC will estimate the column length or diameter based on the elution time input and will now use that data for all calculations.

Communication

Configuring the IP address for the GC

For network (LAN) operation, the GC needs an IP address. It can get this from a DHCP server, or it can be entered directly from the keyboard. In either case, see your LAN administrator.

To use a DHCP server

- 1 Press [**Options**]. Scroll to **Communications** and press [**Enter**].
- 2 Scroll to **Enable DHCP** and press [**On/Yes**]. When prompted, turn the GC off and then on again.

To set the LAN address at the keyboard

- 1 Press [**Options**]. Scroll to **Communications** and press [**Enter**].
- 2 Scroll to **Enable DHCP** and, if necessary, press [**Off/No**]. Scroll to **Reboot GC**. Press [**On/Yes**] and [**On/Yes**].
- 3 Press [**Options**]. Scroll to **Communications** and press [**Enter**].
- 4 Scroll to **IP**. Enter the numbers of the GC IP address, separated by dots, and press [**Enter**]. A message tells you to power cycle the instrument. Do *not* power cycle yet. Press [**Clear**].
- 5 Scroll to **GW**. Enter the Gateway number and press [**Enter**]. A message tells you to power cycle the instrument. Do *not* power cycle yet. Press [**Clear**].
- 6 Scroll to **SM** and press [**Mode/Type**]. Scroll to the appropriate subnet mask from the list given and press [**Enter**]. A message tells you to power cycle the instrument. Do *not* power cycle yet. Press [**Clear**].
- 7 Scroll to **Reboot GC**. Press [**On/Yes**] and [**On/Yes**] to power cycle the instrument and apply the LAN setpoints.

Keyboard and Display

Press [**Options**] and scroll to **Keyboard and Display**. Press [**Mode/Type**].

The following parameters are turned on and off by pressing the [**On/Yes**] or [**Off/No**] keys.

Keyboard lock These keys and functions are operational when the keyboard lock is On:

[**Start**], [**Stop**], and [**Prep Run**]

[**Load**][**Method**] and [**Load**][**Seq**]

[**Seq**]**—**to edit existing sequences

[**Seq Control**]**—**to start or stop sequences.

Hard configuration lock **On** prevents keyboard configuration changes; **Off** removes lock.

Key click Click sound when keys are pressed.

Warning beep Allows you to hear warning beeps.

Warning beep mode There are 9 different warning sounds that may be selected. This allows you to give multiple GCs individual “voices”. We suggest you experiment.

Method modified beep Turn on for high pitched beep when method setpoint is modified.

Press [**Mode/Type**] to change the pressure units and radix type.

Pressure units psi—pounds per square inch, lb/in²

bar—absolute cgs unit of pressure, dyne/cm²

kPa—mks unit of pressure, 10³ N/m²

Language Select English or Chinese.

Radix type Determines the numeric separator type—1.00 or 1,00

Display saver If On, dims the display after a period of inactivity. If Off, disabled.



4 Chromatographic Checkout

About Chromatographic Checkout	68
To Prepare for Chromatographic Checkout	69
To Check FID Performance	71
To Check TCD Performance	76
To Check NPD Performance	81
To Check uECD Performance	86
To Check FPD Performance (Sample 5188-5953)	91
To Verify FPD Performance (Sample 5188-5245)	98



About Chromatographic Checkout

The tests described in this section provide basic confirmation that the GC and detector can perform comparably to factory condition. However, as detectors and the other parts of the GC age, detector performance can change. The results presented here represent typical outputs for typical operating conditions and are not specifications.

The tests assume the following:

- Use of an automatic liquid sampler. If not available, use a suitable manual syringe instead of the syringe listed.
- Use of a 10- μL syringe in most cases. However, a 5- μL syringe is an acceptable substitute for the 1- μL injections described here.
- Use of the septa and other hardware (liners, jets, adapters, and so forth) described. If you substitute other hardware, performance can vary.

Selected tests described in this section can be run automatically using the documentation and utility DVD provided with your GC.

To Prepare for Chromatographic Checkout

Because of the differences in chromatographic performance associated with different consumables, Agilent strongly recommends using the parts listed here for all checkout tests. Agilent also recommends installing new consumable parts whenever the quality of the installed ones is not known. For example, installing a new liner and septum ensures that they will not contribute any contamination to the results.

- 1 Check the indicators/dates on any gas supply traps. Replace/recondition expended traps.
- 2 Install new consumable parts for the inlet and prepare the correct injector syringe (and needle, as needed).

Table 8 Recommended parts for checkout by inlet type

Recommended part for checkout	Part number
Split splitless inlet	
Syringe, 10- μ L	5181-1267
O-ring	5188-5365
Septum	5183-4757
Liner	5183-4711 (FID) 5062-3587 or 5181-3316 (TCD, μ ECD, FPD, NPD)
Multimode inlet	
Syringe, 10- μ L	5181-1267
O-ring	5188-6405
Septum	5183-4757
Liner	5188-6568
Packed column inlet	
Syringe, 10- μ L	5181-1267
O-ring	5080-8898
Septum	5183-4757
Cool on-column inlet	
Septum	5183-4758
Septum nut	19245-80521
Syringe, 5- μ L on-column	5182-0836

Table 8 Recommended parts for checkout by inlet type (continued)

Recommended part for checkout	Part number
0.32-mm needle for 5- μ L syringe	5182-0831
7693A ALS: Needle support insert, COC	G4513-40529
7683B ALS: Needle support assembly for 0.25/0.32 mm injections	G2913-60977
Insert, fused silica, 0.32-mm id	19245-20525
PTV inlet	
Syringe, 10- μ L—for septum head	5181-1267
Syringe, 10- μ L, 23/42/HP—for septumless head	5181-8809
Inlet adapter, Graphpak-2M	5182-9761
Silver seal for Graphpak-2M	5182-9763
Glass liner, multibaffle	5183-2037
Teflon ferrule (septumless head)	5182-9748
Microseal replacement (if installed)	5182-3444
Ferrule, Graphpak-3D	5182-9749

To Check FID Performance

- 1 Gather the following:
 - Evaluation column, HP-5 30 m × 0.32 mm × 0.25 μm (19091J-413)
 - FID performance evaluation (checkout) sample (5188-5372)
 - Chromatographic-grade isooctane
 - 4-mL solvent and waste bottles or equivalent for autoinjector
 - 2-mL sample vials or equivalent for sample
- 2 Verify the following:
 - Capillary column jet installed. If not, [select](#) and [install](#) a capillary column jet.
 - Capillary column adapter installed (adaptable FID only). If not, [install](#) it.
 - Chromatographic-grade gases plumbed and configured: helium as carrier gas, nitrogen, hydrogen, and air.
 - Empty waste vials loaded in sample turret.
 - 4-mL solvent vial with diffusion cap filled with isooctane and inserted in Solvent A injector position.
- 3 Install the evaluation column. (See the procedure for the [SS](#), [PP](#), [COC](#), [MMI](#), or [PTV](#) in the Maintenance manual.)
 - Bake out the evaluation column for at least 30 min at 180 °C. (See the procedure for the [SS](#), [PP](#), [COC](#), [MMI](#), or [PTV](#) in the Maintenance manual.)
 - Be sure to configure the column.
- 4 [Check the FID baseline output](#). The output should be between 5 pA and 20 pA and relatively stable. (If using a gas generator or ultra pure gas, the signal may stabilize below 5 pA.) If the output is outside this range or unstable, resolve this problem before continuing.
- 5 If the output is too low:
 - Check that the electrometer is on.
 - Check that the flame is lit ("[To light the FID flame](#)" on page 300).
- 6 Create or load a method with the parameter values listed in [Table 9](#).

Table 9 FID Checkout Conditions

Column and sample	
Type	HP-5, 30 m × 0.32 mm × 0.25 μm (19091J-413)
Sample	FID checkout 5188-5372
Column flow	6.5 mL/min
Column mode	Constant flow
Split/splitless inlet	
Temperature	250 °C
Mode	Splitless
Purge flow	40 mL/min
Purge time	0.5 min
Septum purge	3 mL/min
Gas saver	Off
Multimode inlet	
Mode	Splitless
Inlet temperature	75 °C
Initial time	0.1 min
Rate 1	720 °C/min
Final temp 1	250 °C
Final time 1	5.0 min
Purge time	1.0 min
Purge flow	40 mL/min
Septum purge	3 mL/min
Packed column inlet	
Temperature	250 °C
Septum purge	3 mL/min
Cool on-column inlet	
Temperature	Oven Track
Septum purge	15 mL/min
PTV inlet	
Mode	Splitless

Table 9 FID Checkout Conditions (continued)

Inlet temperature	75 °C
Initial time	0.1 min
Rate 1	720 °C/min
Final temp 1	350 °C
Final time 1	2 min
Rate 2	100 °C/min
Final temp 2	250 °C
Final time 2	0 min
Purge time	0.5 min
Purge flow	40 mL/min
Septum purge	3 mL/min
Detector	
Temperature	300 °C
H ₂ flow	30 mL/min
Air flow	400 mL/min
Makeup flow (N ₂)	25 mL/min
Lit offset	Typically 2 pA
Oven	
Initial temp	75 °C
Initial time	0.5 min
Rate 1	20 °C/min
Final temp	190 °C
Final time	0 min
ALS settings (if installed)	
Sample washes	2
Sample pumps	6
Sample wash volume	8
Injection volume	1 µL
Syringe size	10 µL
Solvent A pre washes	2
Solvent A post washes	2

Table 9 FID Checkout Conditions (continued)

Solvent A wash volume	8
Solvent B pre washes	0
Solvent B post washes	0
Solvent B wash volume	0
Injection mode (7693A)	Normal
Airgap Volume (7693A)	0.20
Viscosity delay	0
Inject Dispense Speed (7693A)	6000
Plunger speed (7683)	Fast, for all inlets except COC.
PreInjection dwell	0
PostInjection dwell	0
Manual injection	
Injection volume	1 μ L
Data system	
Data rate	5 Hz

- 7** If using a data system, prepare the data system to perform one run using the loaded checkout method. Make sure that the data system will output a chromatogram.

If not using a data system, create a one sample sequence using the GC keypad.

- 8** Start the run.

If performing an injection using an autosampler, start the run using the data system or press **[Start]** on the GC.

If performing a manual injection (with or without a data system):

- a** Press **[Prep Run]** to prepare the inlet for splitless injection.
 - b** When the GC becomes ready, inject 1 μ L of the checkout sample and press **[Start]** on the GC.
- 9** The following chromatogram shows typical results for a new detector with new consumable parts installed and nitrogen makeup gas.

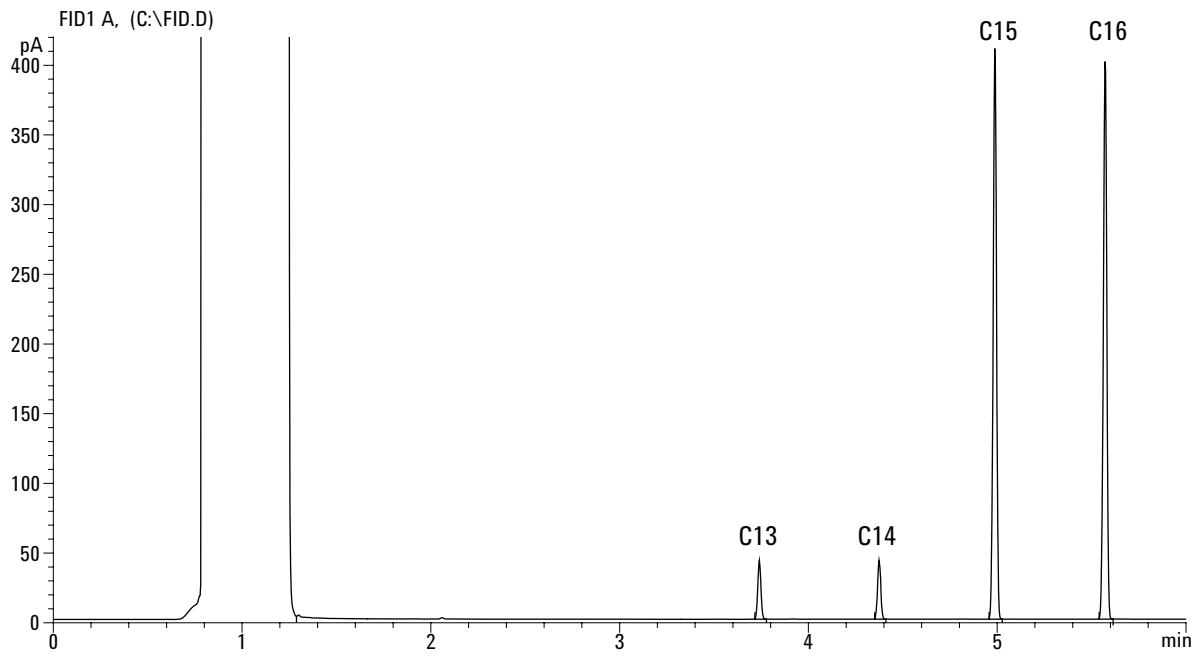

To Check TCD Performance

- 1 Gather the following:
 - Evaluation column, HP- 5 30 m × 0.32 mm × 0.25 μm (19091J- 413)
 - FID/TCD performance evaluation (checkout) sample (18710- 60170)
 - 4- mL solvent and waste bottles or equivalent for autoinjector
 - Chromatographic- grade hexane
 - 2- mL sample vials or equivalent for sample
 - Chromatographic- grade helium as carrier, makeup, and reference gas
- 2 Verify the following:
 - Chromatographic- grade gases plumbed and configured: helium as carrier gas and reference gas.
 - Empty waste vials loaded in sample turret.
 - 4- mL solvent vial with diffusion cap filled with hexane and inserted in Solvent A injector position.
- 3 Install the evaluation column. (See the procedure for the [SS](#), [PP](#), [COC](#), [MMI](#), or [PTV](#) in the Maintenance manual.)
 - Bake out the evaluation column for at least 30 min at 180 °C. (See the procedure for the [SS](#), [PP](#), [COC](#), [MMI](#), or [PTV](#) in the Maintenance manual.)
 - Configure the column
- 4 Create or load a method with the parameter values listed in [Table 10](#).

Table 10 TCD Checkout Conditions

Column and sample	
Type	HP-5, 30 m × 0.32 mm × 0.25 μm (19091J-413)
Sample	FID/TCD checkout 18710-60170
Column flow	6.5 mL/min
Column mode	Constant flow
Split/splitless inlet	
Temperature	250 °C

Table 10 TCD Checkout Conditions (continued)

Mode	Splitless
Purge flow	60 mL/min
Purge time	0.75 min
Septum purge	3 mL/min
Multimode inlet	
Mode	Splitless
Inlet temperature	40 °C
Initial time	0.1 min
Rate 1	720 °C/min
Final temp 1	350 °C
Final time 1	2 min
Purge time	1.0 min
Purge flow	40 mL/min
Septum purge	3 mL/min
Packed column inlet	
Temperature	250 °C
Septum purge	3 mL/min
Cool on-column inlet	
Temperature	Oven track
Septum purge	15 mL/min
PTV inlet	
Mode	Splitless
Inlet temperature	40 °C
Initial time	0.1 min
Rate 1	720 °C/min
Final temp 1	350 °C
Final time 1	2 min
Rate 2	100 °C/min
Final temp 2	250 °C
Final time 2	0 min
Purge time	0.5 min
Purge flow	40 mL/min

Table 10 TCD Checkout Conditions (continued)

Septum purge	3 mL/min
Detector	
Temperature	300 °C
Reference flow (He)	20 mL/min
Makeup flow (He)	2 mL/min
Baseline output	< 30 display counts on Agilent ChemStation (< 750 μ V)
Oven	
Initial temp	40 °C
Initial time	0 min
Rate 1	20 °C/min
Final temp	90 °C
Final time	0 min
Rate 2	15 °C/min
Final temp	170 °C
Final time	0 min
ALS settings (if installed)	
Sample washes	2
Sample pumps	6
Sample wash volume	8
Injection volume	1 μ L
Syringe size	10 μ L
Solvent A pre washes	2
Solvent A post washes	2
Solvent A wash volume	8
Solvent B pre washes	0
Solvent B post washes	0
Solvent B wash volume	0
Injection mode (7693A)	Normal
Airgap Volume (7693A)	0.20
Viscosity delay	0
Inject Dispense Speed (7693A)	6000

Table 10 TCD Checkout Conditions (continued)

Plunger speed (7683)	Fast, for all inlets except COC.
PreInjection dwell	0
PostInjection dwell	0
Manual injection	
Injection volume	1 μ L
Data system	
Data rate	5 Hz

- 5 Display the signal output. A stable output at any value between 12.5 and 750 μ V (inclusive) is acceptable.
 - If the baseline output is < 0.5 display units (< 12.5 μ V), verify that the detector filament is on. If the offset is still < 0.5 display units (< 12.5 μ V), your detector requires service.
 - If baseline output is > 30 display units (> 750 μ V), there may be chemical contamination contributing to the signal. [Bakeout the TCD](#). If repeated cleanings do not give an acceptable signal, check gas purity. Use higher purity gases and/or install traps.
- 6 If using a data system, prepare the data system to perform one run using the loaded checkout method. Make sure that the data system will output a chromatogram.
- 7 Start the run.

If performing an injection using an autosampler, start the run using the data system or press **[Start]** on the GC.

If performing a manual injection (with or without a data system):

 - a Press **[Prep Run]** to prepare the inlet for splitless injection.
 - b When the GC becomes ready, inject 1 μ L of the checkout sample and press **[Start]** on the GC.
- 8 The following chromatogram shows typical results for a new detector with new consumable parts installed.

4 Chromatographic Checkout

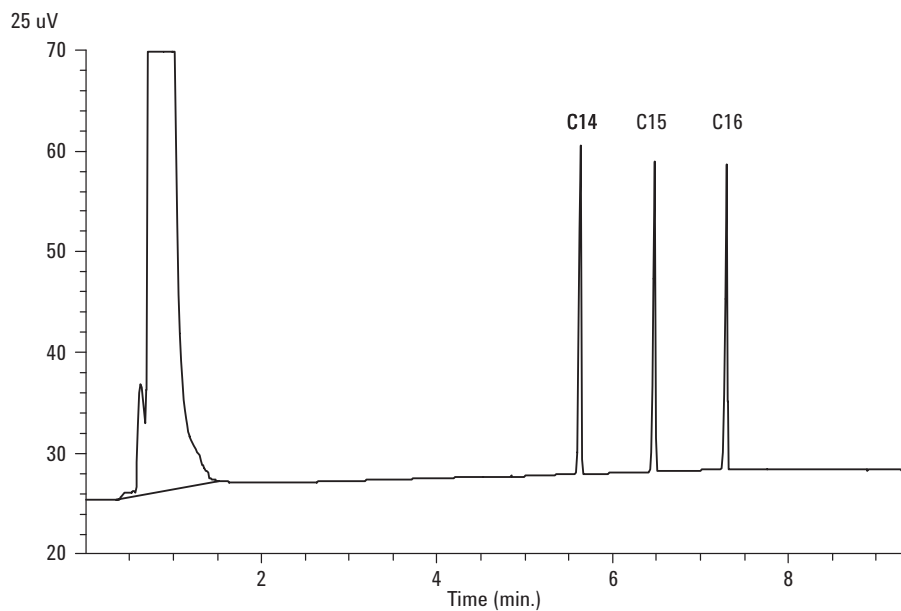

To Check NPD Performance

- 1 Gather the following:
 - Evaluation column, HP-5 30 m × 0.32 mm × 0.25 μm (19091J-413)
 - NPD performance evaluation (checkout) sample (18789-60060)
 - 4- mL solvent and waste bottles or equivalent for autoinjector.
 - Chromatographic- grade isooctane
 - 2- mL sample vials or equivalent for sample.
- 2 Verify the following:
 - Capillary column jet installed. If not, [select](#) and [install](#) a capillary column jet.
 - Capillary column adapter installed. If not, [install](#) it.
 - Chromatographic- grade gases plumbed and configured: helium as carrier gas, nitrogen, hydrogen, and air.
 - Empty waste vials loaded in sample turret.
 - 4- mL vial with diffusion cap filled with isooctane and inserted in Solvent A injector position.
- 3 If present, remove any protective caps from the inlet manifold vents.
- 4 Install the evaluation column. (See the procedure for the [SS](#), [PP](#), [COC](#), [MMI](#), or [PTV](#) in the Maintenance manual.)
 - Bake out the evaluation column for at least 30 min at 180 °C. (See the procedure for the [SS](#), [PP](#), [COC](#), [MMI](#), or [PTV](#) in the Maintenance manual.)
 - Be sure to configure the column
- 5 Create or load a method with the parameter values listed in [Table 11](#).

Table 11 NPD Checkout Conditions

Column and sample	
Type	HP-5, 30 m × 0.32 mm × 0.25 μm (19091J-413)
Sample	NPD checkout 18789-60060
Column mode	Constant flow

Table 11 NPD Checkout Conditions (continued)

Column flow	6.5 mL/min (helium)
Split/splitless inlet	
Temperature	200 °C
Mode	Splitless
Purge flow	60 mL/min
Purge time	0.75 min
Septum purge	3 mL/min
Multimode inlet	
Mode	Splitless
Inlet temperature	60 °C
Initial time	0.1 min
Rate 1	720 °C/min
Final temp 1	350 °C
Final time 1	2 min
Purge time	1.0 min
Purge flow	60 mL/min
Septum purge	3 mL/min
Packed column inlet	
Temperature	200 °C
Septum purge	3 mL/min
Cool on-column inlet	
Temperature	Oven track
Septum purge	15 mL/min
PTV inlet	
Mode	Splitless
Inlet temperature	60 °C
Initial time	0.1 min
Rate 1	720 °C/min
Final temp 1	350 °C
Final time 1	2 min
Rate 2	100 °C/min
Final temp 2	250 °C

Table 11 NPD Checkout Conditions (continued)

Final time 2	0 min
Purge time	0.75 min
Purge flow	60 mL/min
Septum purge	3 mL/min
Detector	
Temperature	300 °C
H ₂ flow	3 mL/min
Air flow	60 mL/min
Makeup flow (N ₂)	Makeup + column = 10 mL/min
Output	30 display units (30 pA)
Oven	
Initial temp	60 °C
Initial time	0 min
Rate 1	20 °C/min
Final temp	200 °C
Final time	3 min
ALS settings (if installed)	
Sample washes	2
Sample pumps	6
Sample wash volume	8
Injection volume	1 µL
Syringe size	10 µL
Solvent A pre washes	2
Solvent A post washes	2
Solvent A wash volume	8
Solvent B pre washes	0
Solvent B post washes	0
Solvent B wash volume	0
Injection mode (7693A)	Normal
Airgap Volume (7693A)	0.20
Viscosity delay	0

Table 11 NPD Checkout Conditions (continued)

Inject Dispense Speed (7693A)	6000
Plunger speed (7683)	Fast, for all inlets except COC.
PreInjection dwell	0
PostInjection dwell	0
Manual injection	
Injection volume	1 μ L
Data system	
Data rate	5 Hz

- 6 If using a data system, prepare the data system to perform one run using the loaded checkout method. Make sure that the data system will output a chromatogram.
- 7 Start the run.

If performing an injection using an autosampler, start the run using the data system, or creating a one sample sequence and pressing **[Start]** on the GC.

If performing a manual injection (with or without a data system):

- a Press **[Prep Run]** to prepare the inlet for splitless injection.
 - b When the GC becomes ready, inject 1 μ L of the checkout sample and press **[Start]** on the GC.
- 8 The following chromatogram shows typical results for a new detector with new consumable parts installed.

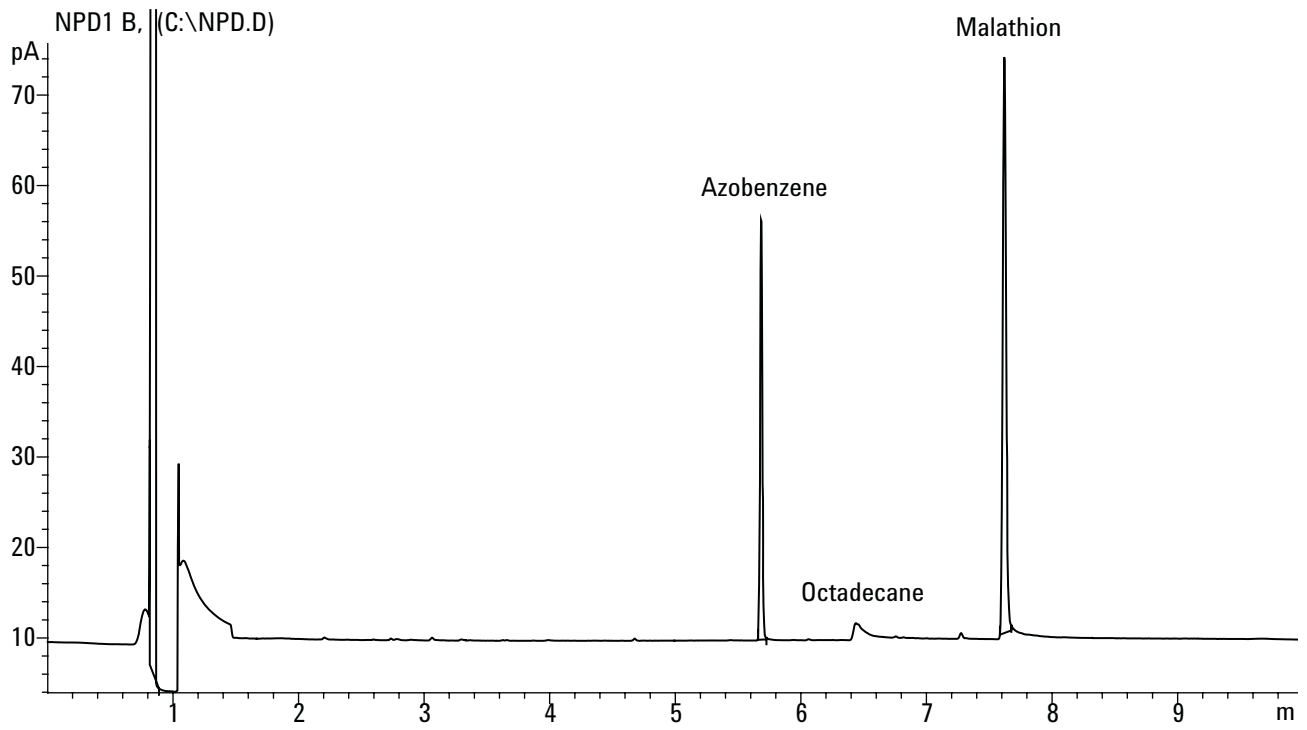

To Check uECD Performance

- 1 Gather the following:
 - Evaluation column, HP-5 30 m × 0.32 mm × 0.25 μm (19091J-413)
 - uECD performance evaluation (checkout) sample (18713-60040, Japan: 5183-0379)
 - 4-mL solvent and waste bottles or equivalent for autoinjector.
 - Chromatographic-grade isooctane
 - 2-mL sample vials or equivalent for sample.
- 2 Verify the following:
 - Clean fused silica indented mixing liner installed. If not, [install it](#).
 - Chromatographic-grade gases plumbed and configured: helium for carrier gas, nitrogen for makeup.
 - Empty waste vials loaded in sample turret.
 - 4-mL vial with diffusion cap filled with hexane and inserted in Solvent A injector position.
- 3 Install the evaluation column. (See the procedure for the [SS](#), [PP](#), [COC](#), [MMI](#), or [PTV](#) in the Maintenance manual.)
 - Bake out the evaluation column for at least 30 minutes at 180 °C. (See the procedure for the [SS](#), [PP](#), [COC](#), [MMI](#), or [PTV](#) in the Maintenance manual.)
 - Be sure to configure the column.
- 4 Display the signal output to determine baseline output. A stable baseline output at any value between 0.5 and 1000 Hz (ChemStation display units) (inclusive) is acceptable.
 - If the baseline output is < 0.5 Hz, verify that the electrometer is on. If the offset is still < 0.5 Hz, your detector requires service.
 - If the baseline output is > 1000 Hz, there may be chemical contamination contributing to the signal. [Bakeout the uECD](#). If repeated cleanings do not give an acceptable signal, check gas purity. Use higher purity gases and/or install traps.
- 5 Create or load a method with the parameter values listed in [Table 12](#).

Table 12 uECD Checkout Conditions

Column and sample	
Type	HP-5, 30 m × 0.32 mm × 0.25 μm (19091J-413)
Sample	μECD checkout (18713-60040 or Japan: 5183-0379)
Column mode	Constant flow
Column flow	6.5 mL/min (helium)
Split/splitless inlet	
Temperature	200 °C
Mode	Splitless
Purge flow	60 mL/min
Purge time	0.75 min
Septum purge	3 mL/min
Multimode inlet	
Mode	Splitless
Inlet temperature	80 °C
Initial time	0.1 min
Rate 1	720 °C/min
Final temp 1	250 °C
Final time 1	5 min
Purge time	1.0 min
Purge flow	60 mL/min
Septum purge	3 mL/min
Packed column inlet	
Temperature	200 °C
Septum purge	3 mL/min
Cool on-column inlet	
Temperature	Oven track
Septum purge	15 mL/min
PTV inlet	
Mode	Splitless

Table 12 uECD Checkout Conditions (continued)

Inlet temperature	80 °C
Initial time	0.1 min
Rate 1	720 °C/min
Final temp 1	350 °C
Final time 1	2 min
Rate 2	100 °C/min
Final temp 2	250 °C
Final time 2	0 min
Purge time	0.75 min
Purge flow	60 mL/min
Septum purge	3 mL/min
Detector	
Temperature	300 °C
Makeup flow (N ₂)	30 mL/min (constant + makeup)
Baseline output	Should be < 1000 display counts in Agilent ChemStation (< 1000 Hz)
Oven	
Initial temp	80 °C
Initial time	0 min
Rate 1	15 °C/min
Final temp	180 °C
Final time	10 min
ALS settings (if installed)	
Sample washes	2
Sample pumps	6
Sample wash volume	8
Injection volume	1 µL
Syringe size	10 µL
Solvent A pre washes	2
Solvent A post washes	2
Solvent A wash volume	8
Solvent B pre washes	0

Table 12 uECD Checkout Conditions (continued)

Solvent B post washes	0
Solvent B wash volume	0
Injection mode (7693A)	Normal
Airgap Volume (7693A)	0.20
Viscosity delay	0
Inject Dispense Speed (7693A)	6000
Plunger speed (7683)	Fast, for all inlets except COC.
PreInjection dwell	0
PostInjection dwell	0
Manual injection	
Injection volume	1 μ L
Data system	
Data rate	5 Hz

6 If using a data system, prepare the data system to perform one run using the loaded checkout method. Make sure that the data system will output a chromatogram.

7 Start the run.

If performing an injection using an autosampler, start the run using the data system or press **[Start]** on the GC.

If performing a manual injection (with or without a data system):

- a** Press **[Prep Run]** to prepare the inlet for splitless injection.
- b** When the GC becomes ready, inject 1 μ L of the checkout sample and press **[Start]** on the GC.

8 The following chromatogram shows typical results for a new detector with new consumable parts installed.

4 Chromatographic Checkout

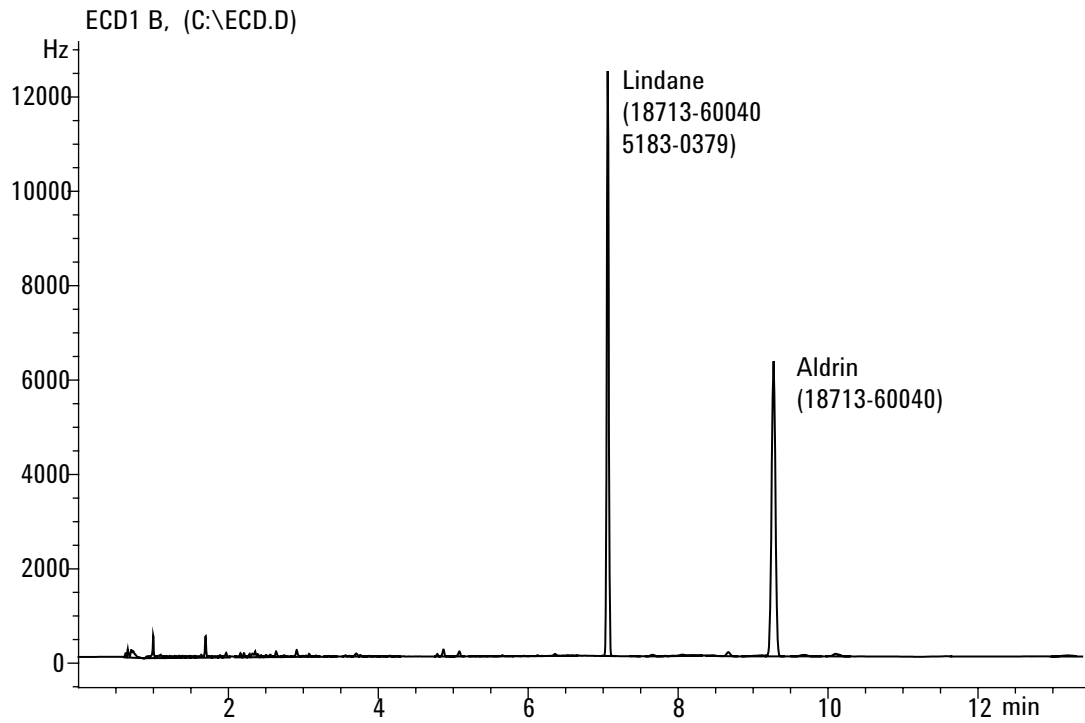

To Check FPD Performance (Sample 5188-5953)

To check FPD performance, first check the phosphorus performance, then the sulfur performance.

Preparation

- 1 Gather the following:
 - Evaluation column, HP-5 30 m × 0.32 mm × 0.25 μm (19091J-413)
 - FPD performance evaluation (checkout) sample (5188-5953)
 - Phosphorus filter
 - Sulfur filter and filter spacer
 - 4-mL solvent and waste bottles or equivalent for autoinjector.
 - 2-mL sample vials or equivalent for sample.
 - Chromatographic-grade isooctane for syringe wash solvent.
- 2 Verify the following:
 - Capillary column adapter installed. If not, [install](#) it.
 - Chromatographic-grade gases plumbed and configured: helium as carrier gas, nitrogen, hydrogen, and air.
 - Empty waste vials loaded in sample turret.
 - 4-mL vial with diffusion cap filled with isooctane and inserted in Solvent A injector position.
- 3 Verify that the **Lit Offset** is set appropriately. Typically, it should be about 2.0 pA for the checkout method.
- 4 Install the evaluation column. (See the procedure for the [SS](#), [PP](#), [COC](#), [MMI](#), or [PTV](#) in the Maintenance manual.)
 - Set the oven, inlet, and detector to 250 °C and bake out for at least 15 minutes. (See the procedure for the [SS](#), [PP](#), [COC](#), [MMI](#), or [PTV](#) in the Maintenance manual.)
 - Be sure to configure the column.

Phosphorus performance

- 5 If it is not already installed, install the [phosphorus filter](#).
- 6 Create or load a method with the parameter values listed in [Table 13](#).

Table 13 FPD Checkout Conditions (P)

Column and sample	
Type	HP-5, 30 m × 0.32 mm × 0.25 μm (19091J-413)
Sample	FPD checkout (5188-5953)
Column mode	Constant pressure
Column pressure	25 psi
Split/splitless inlet	
Temperature	200 °C Split/splitless
Mode	Splitless
Purge flow	60 mL/min
Purge time	0.75 min
Septum purge	3 mL/min
Multimode inlet	
Mode	Splitless
Inlet temperature	75 °C
Initial time	0.1 min
Rate 1	720 °C/min
Final temp 1	250 °C
Final time 1	5.0 min
Purge time	1.0 min
Purge flow	60 mL/min
Septum purge	3 mL/min
Packed column inlet	
Temperature	200 °C
Septum purge	3 mL/min
Cool on-column inlet	
Temperature	Oven track
Septum purge	15 mL/min
PTV inlet	
Mode	Splitless
Inlet temperature	75 °C

Table 13 FPD Checkout Conditions (continued)(P)

Initial time	0.1 min
Rate 1	720 °C/min
Final temp 1	350 °C
Final time 1	2 min
Rate 2	100 °C/min
Final temp 2	250 °C
Final time 2	0 min
Purge time	0.75 min
Purge flow	60 mL/min
Septum purge	3 mL/min
Detector	
Temperature	200 °C (On)
Hydrogen flow	75 mL/min (On)
Air (Oxidizer) flow	100 mL/min (On)
Mode	Constant makeup flow OFF
Makeup flow	60 mL/min (On)
Makeup gas type	Nitrogen
Flame	On
Lit offset	Typically 2 pA
High voltage	On
Oven	
Initial temp	70 °C
Initial time	0 min
Rate 1	25 °C/min
Final temp 1	150 °C
Final time 1	0 min
Rate 2	5 °C/min
Final temp 2	190 °C
Final time 2	4 min
ALS settings (if installed)	
Sample washes	2

Table 13 FPD Checkout Conditions (continued)(P)

Sample pumps	6
Sample wash volume	8
Injection volume	1 μ L
Syringe size	10 μ L
Solvent A pre washes	2
Solvent A post washes	2
Solvent A wash volume	8
Solvent B pre washes	0
Solvent B post washes	0
Solvent B wash volume	0
Injection mode (7693A)	Normal
Airgap Volume (7693A)	0.20
Viscosity delay	0
Inject Dispense Speed (7693A)	6000
Plunger speed (7683)	Fast, for all inlets except COC.
PreInjection dwell	0
PostInjection dwell	0
Manual injection	
Injection volume	1 μ L
Data system	
Data rate	5 Hz

7 Ignite the FPD flame, if not lit.

8 Display the signal output and monitor. This output typically runs between 40 and 55 but can be as high as 70. Wait for the output to level off. This takes approximately 1 hour.

If the baseline output is too high:

- Check column installation. If installed high, the stationary phase burns out and increases measured output.
- Check for leaks.
- Bake out the detector and column at 250 °C.
- Wrong flows set for installed filter.

If the baseline output is zero, verify the electrometer is on and the flame is lit.

- 9 If using a data system, prepare the data system to perform one run using the loaded checkout method. Make sure that the data system will output a chromatogram.
- 10 Start the run.

If performing an injection using an autosampler, start the run using the data system or press **[Start]** on the GC.

If performing a manual injection (with or without a data system):

- a Press **[Prep Run]** to prepare the inlet for splitless injection.
 - b When the GC becomes ready, inject 1 μL of the checkout sample and press **[Start]** on the GC.
- 11 The following chromatogram shows typical results for a new detector with new consumable parts installed.

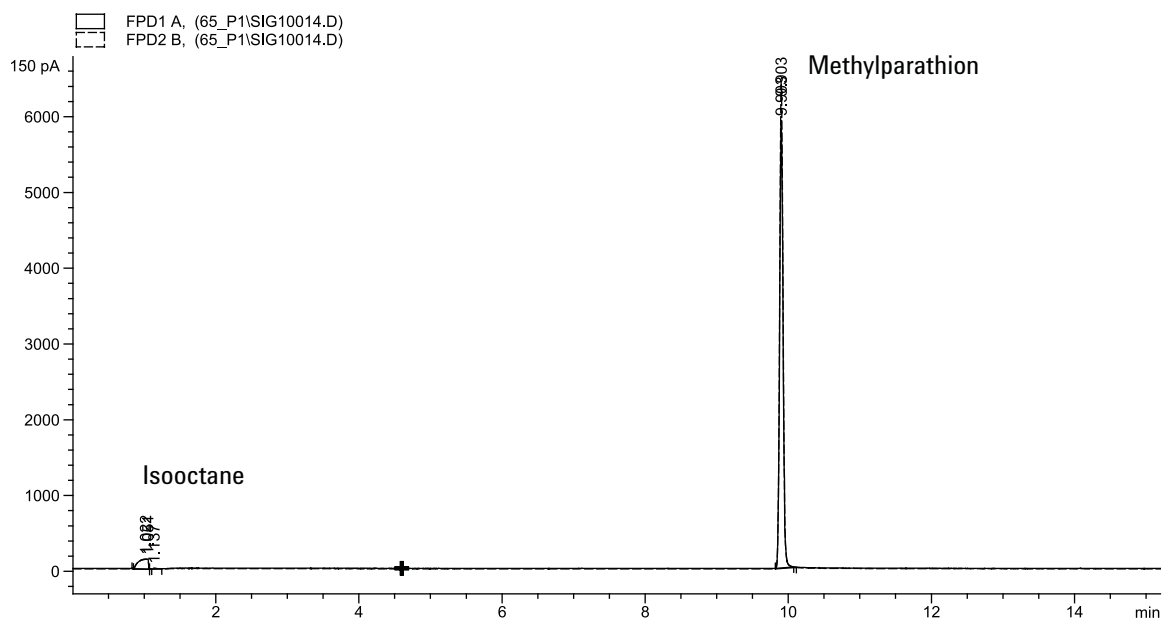

Table 14 Evaluating checkout runs

FPD P filter	Typical range after 24 hours	Limits at installation
MDL (pg/sec)	0.06 to 0.08	≤ 0.10
Peak area	19000 to 32000	≥ 19000
Signal height	5000 to 11000	—

Table 14 Evaluating checkout runs

FPD P filter	Typical range after 24 hours	Limits at installation
Noise	1.6 to 3.0	≤4
Half-width (min)	0.05 to 0.07	—
Output	34 to 80	≤80

Sulfur performance

- 12 Install the [sulfur filter and filter spacer](#).
- 13 Make the following method parameter changes.

Table 15 Sulfur method parameters (S)

Parameter	Value (mL/min)
H ₂ flow	50
Air flow	60

- 14 Ignite the FPD flame if not lit.
- 15 Display the signal output and monitor. This output typically runs between 50 and 60 but can be as high as 70. Wait for the output to level off. This takes approximately 1 hour.

If the baseline output is too high:

- Check column installation. If installed high, the stationary phase burns out and increases measured output.
- Check for leaks.
- Bake out the detector and column at 250 °C.
- Wrong flows set for installed filter.

If the baseline output is zero, verify the electrometer is on and the flame is lit.

- 16 If using a data system, prepare the data system to perform one run using the loaded checkout method. Make sure that the data system will output a chromatogram.
- 17 Start the run.

If performing an injection using an autosampler, start the run using the data system or press **[Start]** on the GC.

If performing a manual injection (with or without a data system):

- a Press **[Prep Run]** to prepare the inlet for splitless injection.
 - b When the GC becomes ready, inject 1 μL of the checkout sample and press **[Start]** on the GC.
- 18 The following chromatogram shows typical results for a new detector with new consumable parts installed.

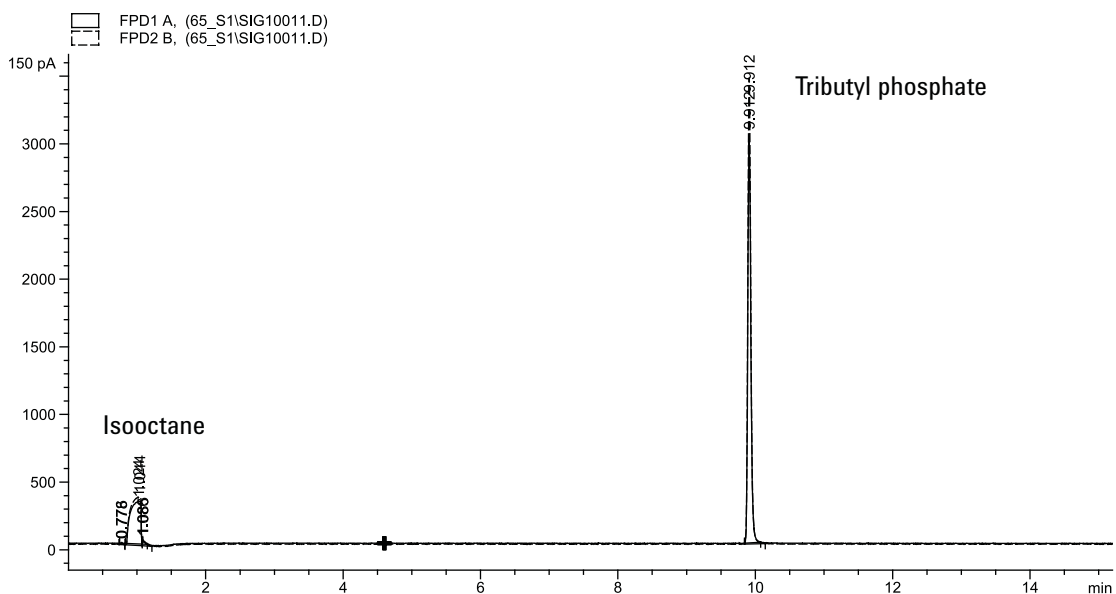

Table 16 Evaluating checkout runs

FPD S filter	Typical range after 24 hours	Limits at installation
MDL (pg/s)	3.8 to 5	≤ 6
Peak area	8000 to 19000	≥ 8000
Signal height	2500 to 6000	—
Noise	2 to 4	≤ 5
Half-width (min)	0.06 to 0.08	—
Output	34 to 65	≤ 70

To Verify FPD Performance (Sample 5188-5245)

To verify FPD performance, first check the phosphorus performance, then the sulfur performance.

Preparation

- 1 Gather the following:
 - Evaluation column, DB5 15 m × 0.32 mm × 1.0 μm (123- 5513)
 - FPD performance evaluation (checkout) sample (5188- 5245)
 - Phosphorus filter
 - Sulfur filter and filter spacer
 - 4- mL solvent and waste bottles or equivalent for autoinjector.
 - 2- mL sample vials or equivalent for sample.
 - Chromatographic- grade isooctane for syringe wash solvent.
- 2 Verify the following:
 - Capillary column adapter installed. If not, [install](#) it.
 - Chromatographic- grade gases plumbed and configured: helium as carrier gas, nitrogen, hydrogen, and air.
 - Empty waste vials loaded in sample turret.
 - 4- mL vial with diffusion cap filled with isooctane and inserted in Solvent A injector position.
- 3 Verify the lit offset is set appropriately. Typically, it should be about 2.0 pA for the checkout method.
- 4 Install the evaluation column. (See the procedure for the [SS](#), [PP](#), [COC](#), [MMI](#), or [PTV](#) in the Maintenance manual.)
 - Set the oven, inlet, and detector to 250 °C and bake out for at least 15 minutes. (See the procedure for the [SS](#), [PP](#), [COC](#), [MMI](#), or [PTV](#) in the Maintenance manual.)
 - Configure the column.

Phosphorus performance

- 5 If it is not already installed, install the [phosphorus filter](#).
- 6 Create or load a method with the parameter values listed in [Table 17](#).

Table 17 FPD Phosphorus Checkout Conditions

Column and sample	
Type	DB-5MS, 15 m × 0.32 mm × 1.0 μm (123-5513)
Sample	FPD checkout (5188-5245)
Column mode	Constant flow
Column flow	7.5 mL/min
Split/splitless inlet	
Temperature	250 °C
Mode	Splitless
Total purge flow	69.5 mL/min
Purge flow	60 mL/min
Purge time	0.75 min
Septum purge	3 mL/min
Multimode inlet	
Mode	Splitless
Inlet temperature	80 °C
Initial time	0.1 min
Rate 1	720 °C/min
Final temp 1	250 °C
Final time 1	5.0 min
Purge time	1.0 min
Purge flow	60 mL/min
Septum purge	3 mL/min
Packed column inlet	
Temperature	250 °C
Septum purge	3 mL/min
Cool on-column inlet	
Temperature	Oven track
Septum purge	15 mL/min
PTV inlet	
Mode	Splitless

Table 17 FPD Phosphorus Checkout Conditions (continued)

Inlet temperature	80 °C
Initial time	0.1 min
Rate 1	720 °C/min
Final temp 1	350 °C
Final time 1	2 min
Rate 2	100 °C/min
Final temp 2	250 °C
Final time 2	0 min
Purge time	0.75 min
Purge flow	60 mL/min
Septum purge	3 mL/min
Detector	
Temperature	200 °C (On)
Hydrogen flow	75.0 mL/min (On)
Air (oxidizer) flow	100.0 mL/min (On)
Mode	Constant makeup flow Off
Makeup flow	60.0 mL/min (On)
Makeup gas type	Nitrogen
Flame	On
Lit offset	Typically 2 pA
High voltage	On
Oven	
Initial temp	70 °C
Initial time	0 min
Rate 1	10 °C/min
Final temp	105 °C
Final time	0 min
Rate 2	20 °C/min
Final temp 2	190 °C
Final time 2	7.25 min for sulfur 12.25 min for phosphorus
ALS settings (if installed)	

Table 17 FPD Phosphorus Checkout Conditions (continued)

Sample washes	2
Sample pumps	6
Sample wash volume	8
Injection volume	1 μ L
Syringe size	10 μ L
Solvent A pre washes	2
Solvent A post washes	2
Solvent A wash volume	8
Solvent B pre washes	0
Solvent B post washes	0
Solvent B wash volume	0
Injection mode (7693A)	Normal
Airgap Volume (7693A)	0.20
Viscosity delay	0
Inject Dispense Speed (7693A)	6000
Plunger speed (7683)	Fast, for all inlets except COC.
PreInjection dwell	0
PostInjection dwell	0
Manual injection	
Injection volume	1 μ L
Data System	
Data rate	5 Hz

7 Ignite the FPD flame, if not lit.

8 Display the signal output and monitor. This output typically runs between 40 and 55 but can be as high as 70. Wait for the output to level off. This takes approximately 1 hour.

If the baseline output is too high:

- Check column installation. If installed high, the stationary phase burns out and increases measured output.
- Check for leaks.
- Bake out the detector and column at 250 °C.
- Wrong flows set for installed filter

If the baseline output is zero, verify the electrometer is on and the flame is lit.

- 9 If using a data system, prepare the data system to perform one run using the loaded checkout method. Make sure that the data system will output a chromatogram.
- 10 Start the run.

If performing an injection using an autosampler, start the run using the data system or press **[Start]** on the GC.

If performing a manual injection (with or without a data system):

- a Press **[Prep Run]** to prepare the inlet for splitless injection.
 - b When the GC becomes ready, inject 1 μL of the checkout sample and press **[Start]** on the GC.
- 11 The following chromatogram shows typical results for a new detector with new consumable parts installed.

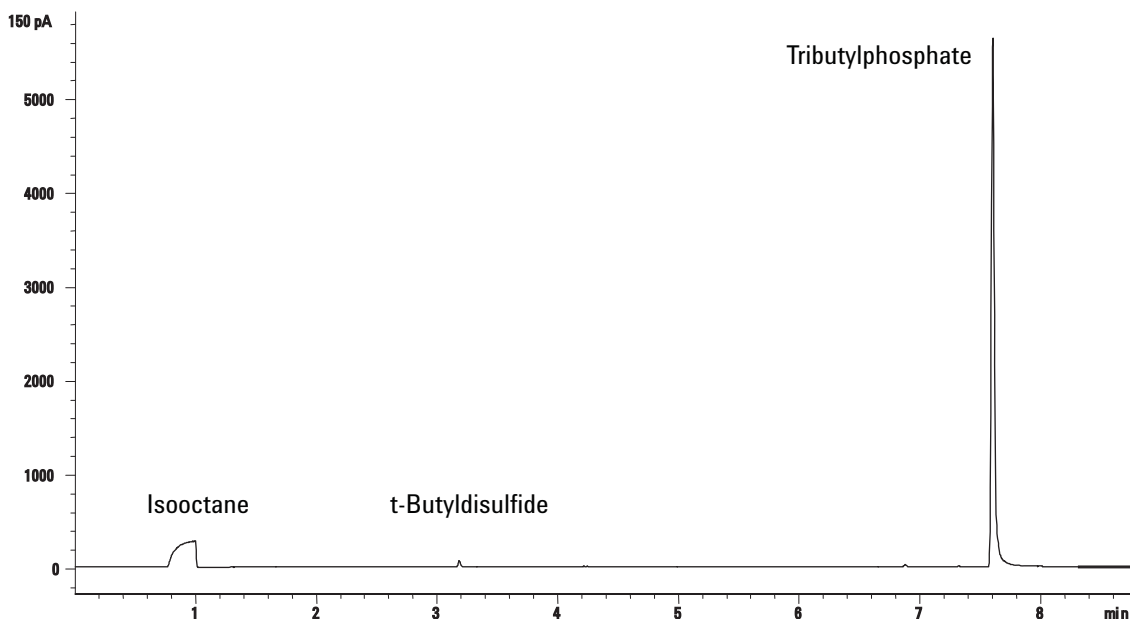

Table 18 Evaluating checkout runs

FPD P filter	Typical range after 24 hours	Limits at installation
MDL (pg/sec)	0.06 to 0.08	≤ 0.10
Peak area	19000 to 32000	≥ 19000
Signal height	5000 to 11000	—

Table 18 Evaluating checkout runs

FPD P filter	Typical range after 24 hours	Limits at installation
Noise	1.6 to 3.0	≤4
Half-width (min)	0.05 to 0.07	—
Output	34 to 80	≤80

Sulfur performance

- 12 Install the [sulfur filter](#).
- 13 Make the following method parameter changes.

Table 19 Sulfur method parameters

Parameter	Value (mL/min)
H ₂ flow	50
Air flow	60

- 14 Ignite the FPD flame, if not lit.
- 15 Display the signal output and monitor. This output typically runs between 50 and 60 but can be as high as 70. Wait for the output to level off. This takes approximately 2 hours.

If the baseline output is too high:

- Check column installation. If installed high, the stationary phase burns out and increases measured output.
- Check for leaks.
- Bake out the detector and column at 250 °C.
- Wrong flows set for installed filter

If the baseline output is zero, verify the electrometer is on and the flame is lit.

- 16 If using a data system, prepare the data system to perform one run using the loaded checkout method. Make sure the data system will output a chromatogram.
- 17 Start the run.

If performing an injection using an autosampler, start the run using the data system or press **[Start]** on the GC.

4 Chromatographic Checkout

If performing a manual injection (with or without a data system):

- a Press **[Prep Run]** to prepare the inlet for splitless injection.
- b When the GC becomes ready, inject 1 μL of the checkout sample and press **[Start]** on the GC.

18 The following chromatogram shows typical results for a new detector with new consumable parts installed.

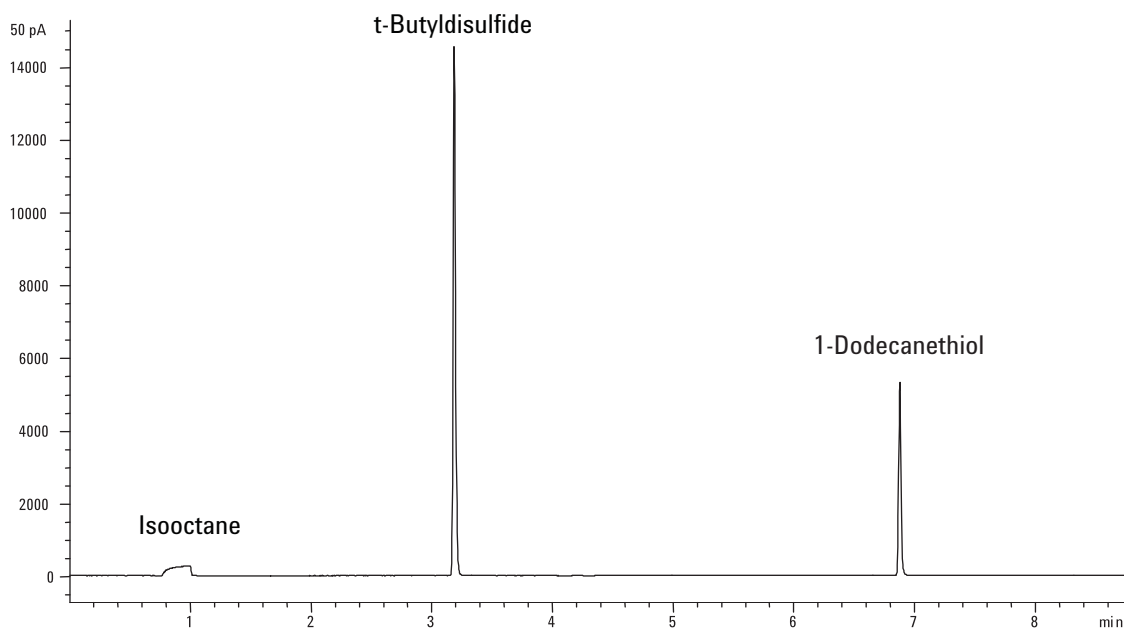

Table 20 Evaluating checkout runs

FPD S filter	Typical range after 24 hours	Limits at installation
MDL (pg/s)	3.8 to 5	≤ 6
Peak area	8000 to 19000	≥ 8000
Signal height	2500 to 6000	—
Noise	2 to 4	≤ 5
Half-width (min)	0.06 to 0.08	—
Output	34 to 65	≤ 70



5 Methods and Sequences

- Creating Methods 106
 - To program a method 107
 - To program the ALS 107
 - To program the ALS sampler tray 107
 - To program the 7683B ALS bar code reader 108
 - To save a method 109
 - To load a stored method 109
 - Method mismatch 109
- Creating Sequences 111
 - About the priority sequence 111
 - To program a sequence 111
 - To program a priority sequence 112
 - To program an ALS subsequence 113
 - To program a valve subsequence 113
 - To program post sequence events 113
 - To save a sequence 114
 - To load a stored sequence 114
 - To determine sequence status 114
 - To start a sequence 114
 - To pause and resume a sequence 115
 - To stop a sequence 115
 - To abort a sequence 115



Creating Methods

A method is the group of setpoints needed to run a single sample on the GC, such as oven temperature programs, pressure programs, inlet temperatures, sampler parameters, etc. A method is created by saving a group of setpoints as a numbered method using the **[Store]** key. At least 10 methods can be stored.

Components for which setpoint parameters can be stored are shown in [Table 21](#).

Table 21 Setpoint parameter components

Component	Component
Oven	Aux temp
Valve 1–8	Aux EPC
Front and back inlet	Aux column
Columns 1 to 6	Aux detector 1 and 2
Front and back detector	Post run
Analog 1 and 2	Run table
Front and back injector (see Table 22)	Sample tray

[Table 22](#) lists the setpoint parameters for the 7683B ALS.

Table 22 7683B ALS setpoint parameters

Parameter	Parameter
Injection volume	Sample Draw Speed
Viscosity delay	Sample Disp Speed
Inject Dispense Speed	Solvent Draw Speed
Sample pumps	Solvent Disp Speed
Sample washes	Slow plunger
Solvent A post washes	Pre dwell time
Solvent A pre washes	Post dwell time
Solvent B post washes	Sample offset
Solvent B pre washes	Injection Reps
Solvent B wash volume	Injection Delay

The GC also saves ALS setpoints. See the [7693A Installation, Operation, and Maintenance](#) manual for details on its setpoints.

Setpoint parameters are saved when the GC is turned off and loaded when you turn the instrument back on. However, if the hardware was changed while the instrument was turned off, it may not be possible to restore all setpoints in the method.

To program a method

- 1 Individually select each component for which setpoint parameters are appropriate for your method. (See [Table 21](#).)
- 2 Examine the current setpoints and modify as desired. Repeat for each component as appropriate.
- 3 Examine the current setpoints for the ALS, if appropriate, and modify as desired. (See [“To program the ALS”](#) on page 107.)
- 4 Save the setpoints as a stored method. (See [“To save a method”](#) on page 109.)

To program the ALS

- 1 Press **[Front Injector]** or **[Back Injector]**.
- 2 Scroll to the desired setpoint. (See [Table 22](#).)
- 3 Enter a setpoint value.
- 4 Examine the current setpoints for the sampler tray, if appropriate, and modify as desired. (See [“To program the ALS sampler tray”](#) on page 107.)
- 5 Examine the current setpoints for the bar code reader, if appropriate, and modify as desired. (See [“To program the 7683B ALS bar code reader”](#) on page 108.)
- 6 Save the setpoints as a stored method. (See [“To save a method”](#) on page 109.)

To program the ALS sampler tray

For the 7693A sampler tray, see the [7693A Installation, Operation, and Maintenance](#) manual.

For the 7683B sampler tray:

- 1 Press **[Sample tray]**.
- 2 Press **[On/Yes]** to enable the barcode reader (if present) or **[Off/No]** to disable it.

Configuration issues

- 1 To edit the sample tray configuration setpoints, press **[Config][Sample Tray]**.

Normally, no tray configuration is required. If using a bar code reader and the tray gripper arm has difficulties retrieving a vial from the bar code reader, adjust the gripper offset (step 2). If the sample vial contacts the side of the turret hole when the tray delivers or retrieves the sample vial, then adjust the injector offset (step 3).

- 2 Scroll to **Grip offset** and press **[Mode/Type]**. Select from:
 - **Up** to raise the gripper arm pickup height
 - **Default**
 - **Down** to lower the gripper arm pickup height

and press **[Enter]**.

- 3 Scroll to **Front Injector Offset** or **Back Injector Offset** and press **[Mode/Type]**. Select from:
 - **Clockwise** to have the gripper arm meet the turret at a further clockwise position (relative to turret rotation)
 - **Default**
 - **CounterClockwise** to have the gripper arm meet the turret at a further counterclockwise position (relative to turret rotation)

and press **[Enter]**.

To program the 7683B ALS bar code reader

For the 7693A sampler bar code reader, see the [7693A Installation, Operation, and Maintenance](#) manual.

- 1 Press **[Sample tray]**.
- 2 Scroll to **Enable bar code reader** and press **[On/Yes]** to enable or **[Off/No]** to disable the bar code reader.

Configuration issues

- 1 To edit the bar code configuration setpoints, press **[Config][Sample Tray]**.
- 2 Select **Bar Code Reader**.
- 3 Press **[On/Yes]** or **[Off/No]** to control the following bar code setpoints:

- **Enable 3 of 9**—encodes both letters and numbers, plus a few punctuation marks, and message length can be varied to suit both the amount of data to be encoded and the space available
 - **Enable 2 of 5**—restricted to numbers but does allow variable message length
 - **Enable UPC code**—restricted to numbers- only with fixed message length
 - **Enable checksum**—verifies that the checksum in the message matches the checksum calculated from the message characters, but does not include the checksum character in the returned message
- 4 Enter **3** as the **BCR Position** when the reader is installed in the front of the tray. Positions 1–19 are available.

To save a method

- 1 Press [**Method**] and scroll to the desired method number.
- 2 Press [**Store**] and [**On/Yes**] to store the new method using the chosen number. Alternatively, press [**Off/No**] to return to the stored methods list without saving the method.

A message is displayed if a method with the number you selected already exists.

- Press [**On/Yes**] to *replace* the existing method or [**Off/No**] to return to the stored methods list without saving the method.

To load a stored method

Press [**Load**][**Method**]. Supply the method number and press [**Enter**]. The specified method will replace the current active method.

Method mismatch

This section applies *only* to a standalone (not connected to a data system) GC. When a data system, such as a ChemStation or EZChrom Elite, controls the GC, methods are stored in the data system and can be edited there. See your data system documentation for more information.

Suppose your standalone GC is equipped with a single FID. You have created and saved methods that use this detector. Now you remove the FID and install a TCD in its place. When you try to load one of your stored methods, you observe an error message saying that the method and the hardware do not match.

The problem is that the actual hardware is no longer the same as the hardware configuration saved in the method. The method cannot run because it does not know how to operate the recently-added TCD.

On inspecting the method, you find that the detector-related parameters have all been reset to the default values.

Correcting a method mismatch on a standalone GC

This problem can be avoided if you follow this procedure for any hardware change, even including the simple replacement of a defective detector board.

- 1 Before changing any hardware, press **[Config][hardware module]**, where **[hardware module]** is the device you intend to replace.
- 2 Press **[Mode/Type]**. Select **Remove module** and press **[Enter]**. The module is now **Unconfigured**.
- 3 Turn the GC off.
- 4 Make the hardware change that you intended (in this example, remove the FID and its flow module and replace them with the TCD and its module).
- 5 Turn the GC on. Press **[Config][hardware module]**.
- 6 Press **[Mode/Type]**. Select **Install module** and press **[Enter]**. The GC will install the new hardware module, which corrects the active method (but not the stored one!).
- 7 Save the corrected method using the same number (which overwrites the stored method) or a new number (which saves both versions of the method).

Creating Sequences

A sequence specifies the samples to be run and the stored method to be used for each. The sequence is divided into a priority sequence (ALS only), subsequences (each of which uses a single method), and post-sequence events

- Priority sequence—allows you to interrupt a running ALS or valve sequence to analyze urgent samples. (See [“About the priority sequence”](#) on page 111.)
- Subsequences—contain the stored method number and information that defines a set of samples and calibrators to be analyzed using a particular method. Sampler and/or valve subsequences can be used in the same sequence.
- Post sequence—names a method to be loaded and run after the last run in the last subsequence. Specifies whether the sequence is to be repeated indefinitely or halted after the last subsequence.

Samples in each subsequence are specified as either ALS tray locations or sampling valve positions (gas or liquid sampling valves, often with a stream selection valve).

Five sequences with up to five subsequences each can be stored.

About the priority sequence

The priority sequence consists of a single sampler or valve subsequence and a special **Use priority** parameter, which can be activated at any time, even when a sequence is running. This feature allows you to interrupt a running sequence without having to edit it.

If **Use priority** is **On**, then:

- 1 The GC and ALS complete the current run, then the sequence pauses.
- 2 The GC runs the priority sequence.
- 3 The GC resets the **Use priority** parameter to **Off**.
- 4 The main sequence resumes where it paused.

To program a sequence

- 1 Press [**Seq**]. (Press again, if necessary, to display subsequence information.)
- 2 Create a priority sequence, if desired. (See [“To program a priority sequence”](#) on page 112.) If you might want to use a

priority sequence, you must program it now. (Once the sequence starts, you cannot edit it without stopping it.)

- 3 Scroll to the **Method #** line of **Subseq 1** and enter a method number. Use **0** for the currently active method, **1 to 9** for the stored methods, or **[Off/No]** to end the sequence.
- 4 Press **[Mode/Type]** to select a valve or injector type. (See “[To program a valve subsequence](#)” on page 113 or “[To program an ALS subsequence](#)” on page 113.)
- 5 Create the next subsequence or scroll to **Post Sequence**. (See “[To program post sequence events](#)” on page 113.)
- 6 Save the completed sequence. (See “[To save a sequence](#)” on page 114.)

To program a priority sequence

- 1 Press **[Seq]**. (Press again, if necessary, to display subsequence information.)
- 2 Scroll to **Priority Method #** and enter a method number. Use **0** for the currently active method, **1 to 9** for the stored methods, or **[Off/No]** to end the sequence. Press **[Enter]**.

The active method, 0, will change during the sequence if the subsequences use stored methods. Therefore, method 0 should be chosen for the priority sequence only if all subsequences use method 0.

- 3 Press **[Mode/Type]** and select the injector type.
- 4 Program the ALS subsequence. (See “[To program an ALS subsequence](#)” on page 113.)
- 5 Store the completed sequence. (See “[To save a sequence](#)” on page 114.)

Once a priority subsequence exists in a sequence, you can activate it when the urgent samples are ready to be processed by:

- 1 Press **[Seq]**. (Press again, if necessary, to display subsequence information.)
- 2 Scroll to **Use Priority** and press **[On/Yes]**.

When the priority samples are completed, the normal sequence resumes.

To program an ALS subsequence

- 1 See [step 1](#) through [step 3](#) of “To program a sequence” on page 111.
- 2 Press [**Mode/Type**] and select the injector type.
- 3 Enter injector sequence parameters (if using both injectors, there will be two sets of parameters):
 - **Number of Injections/vial**—the number of repeat runs from each vial. Enter **0** if no samples are to be injected.
 - **Samples**—the range (first–last) of sample vials to be analyzed.
- 4 Proceed with [step 5](#) of “To program a sequence” on page 111.

To program a valve subsequence

- 1 See [step 1](#) through [step 3](#) of “To program a sequence” on page 111.
- 2 Press [**Mode/Type**] and select **Valve**.
- 3 Enter the valve sequence parameters (the first three appear only if a multiposition valve is configured):
 - **#inj/position**—number of injections at each position (0–99)
 - **Position rng**—first–last valve positions to sample (1–32)
 - **Times thru range**—number of times to repeat the range (1–99)
 - **# injections**—number of injections for each sample
- 4 Proceed with [step 5](#) of “To program a sequence” on page 111.

To program post sequence events

- 1 See [step 1](#) through [step 4](#) of “To program a sequence” on page 111.
- 2 Scroll to the **Method #** line of **Post Sequence** and enter a method number. Use **1** to **9** for the stored methods, or **0** if there is no method to be loaded.
- 3 Press [**On/Yes**] at **Repeat sequence** to keep repeating the sequence (useful for valve sequences). Otherwise, press [**Off/No**] to halt the sequence when all subsequences are finished.

To save a sequence

- 1 Press [**Store**][**Seq**].
- 2 Enter an identifying number for the sequence.
- 3 Press [**On/Yes**] to store the sequence. Alternatively, press [**Off/No**] to cancel.

A message is displayed if a sequence with the number you selected already exists.

- Press [**On/Yes**] to replace the existing sequence or [**Off/No**] to cancel.

Sequences can also be stored from within the stored sequence list ([**Seq**]) by scrolling to the appropriate sequence number and pressing the [**Store**] key.

To load a stored sequence

Press [**Load**][**Seq**]. Supply the sequence number and press [**Enter**]. The specified sequence will replace the current active sequence.

To determine sequence status

Press [**Seq Control**] to display the current status of the active sequence. There are six possible sequence status modes:

- Start/running
- Ready wait
- Paused/resume
- Stopped
- Aborted
- No sequence

To start a sequence

Press [**Seq Control**], scroll to **Start sequence** and press [**Enter**].

The sequence status will change to **Running**. The sequence continues to run until all subsequences are executed, or until one of the events described under “[To abort a sequence](#)” on page 115 occurs.

Ready wait

If a sequence is started but the instrument is not ready (due to oven temperature, equilibration times, etc.), the sequence will not start until all instrument setpoints are ready

To pause and resume a sequence

Press [**Seq Control**], scroll to **Pause sequence**, and press [**Enter**]. The sequence status changes to **paused**, and you are given the option to resume or stop the paused sequence.

The sequence halts when the current sample run is complete.

To continue the paused sequence, scroll to **Resume sequence** and press [**Enter**]. When a sequence is resumed, it starts with the next sample.

To stop a sequence

A sequence automatically stops at the end of the last active subsequence unless **Repeat sequence** is **On** in the Post Sequence events.

To stop a running sequence, scroll to **Stop sequence** and press [**Enter**]. A stopped sequence can only be restarted from the beginning.

To abort a sequence

When a sequence is aborted, it stops immediately without waiting for the current run to finish. These actions will cause a sequence to abort:

- A run is stopped by pressing [**Stop**].
- A sampler error occurs producing an error message.
- The GC detects a configuration mismatch during a method load.
- A running sequence tries to load an empty method.
- The sampler is turned off. You can correct the problem and then resume the sequence. The aborted sample run will be repeated.



6 Checking for Leaks

Preparing the GC for Maintenance	118
To Check for External Leaks	120
To Check for GC Leaks	121
Leaks in Capillary Column (Microfluidic) Fittings	122
To Perform a SS Inlet Pressure Decay Test	123
To Correct Leaks in the Split Splitless Inlet	127
To Perform a Multimode Inlet Pressure Decay Test	128
To Correct Leaks in the Multimode Inlet	132
To Perform a SS Inlet Pressure Decay Test	133
To Correct Leaks in the Packed Column Inlet	137
To Perform a COC Pressure Decay Test	138
To Correct Leaks in the Cool On-Column Inlet	141
To Perform a PTV Pressure Decay Test	142
To Correct Leaks in the PTV Inlet	146
To Perform a VI Pressure Decay Test	147
To Prepare the VI for a Closed System Leak Check	150
To Correct Leaks in the Volatiles Interface	151

Preparing the GC for Maintenance

Before most maintenance procedures, the GC must be made ready. The purpose of this preparation is to avoid damage to both the instrument (electronics, columns, etc.) and the user (shocks, burns).

Column and oven preparation

The main hazards here are temperature (burns) and column exposure to air.

- Cool the oven by changing its setpoint to 35 °C. This allows the oven fan to assist cooling.
- Leave the carrier gas flow **On** until the oven has cooled. This protects the column from oxygen damage.

Inlet preparation

We are concerned with the possibility of burns and air intrusion into the column.

- *After the oven and columns have cooled*, reduce all inlet flows to 0.0 and turn the temperatures **Off**.
- For inlet-only maintenance, leave all detectors at their normal setpoints except for the TCD filament, which should be turned **Off**.
- If the column is to be removed, cap both ends to keep air out.

Detector preparation

This is another burn hazard area, plus the possibility of damage to the very sensitive electronics.

Some detectors (uECD, FPD, NPD) require 12 hours or longer to stabilize from the detector-off condition.

- To cool the detector, reduce the temperature setpoint to 35 °C.
- Some detectors (FID, NPD, FPD) use high voltages. The high voltage supply is part of the electrometer. Turn it **Off** to disable the high voltage.
- The filament in the TCD will be damaged if exposed to air while hot. To protect the filament, turn it **Off**.

Leak Check Tips

When checking for leaks, consider the system in two parts: external leak points and GC leak points.

- **External leak points** include the gas cylinder (or gas purifier), regulator and its fittings, supply shutoff valves, and connections to the GC supply fittings.
- **GC leak points** include inlets, detectors, column connections, valve connections, and connections between flow modules and inlets/detectors.

WARNING

Hydrogen (H₂) is flammable and is an explosion hazard when mixed with air in an enclosed space (for example, a flow meter). Purge flowmeters with inert gas as needed. Always measure gases individually. Always turn off detectors to prevent flame/bead autoignition.

WARNING

Hazardous sample gases may be present.

- 1 Gather the following:
 - Electronic leak detector capable of detecting the gas type
 - 7/16, 9/16, and 1/4- inch wrenches for tightening Swagelok and column fittings
- 2 Check any potential leak points associated with any maintenance recently performed.
- 3 Check GC fittings and connections that undergo thermal cycling, since thermal cycling tends to loosen some fitting types. Use the electronic leak detector to determine if a fitting is leaking.
 - Start by checking any newly made connections.
 - Remember to check connections in the gas supply lines after changing traps or supply cylinders.

To Check for External Leaks

Check for leaks at these connections:

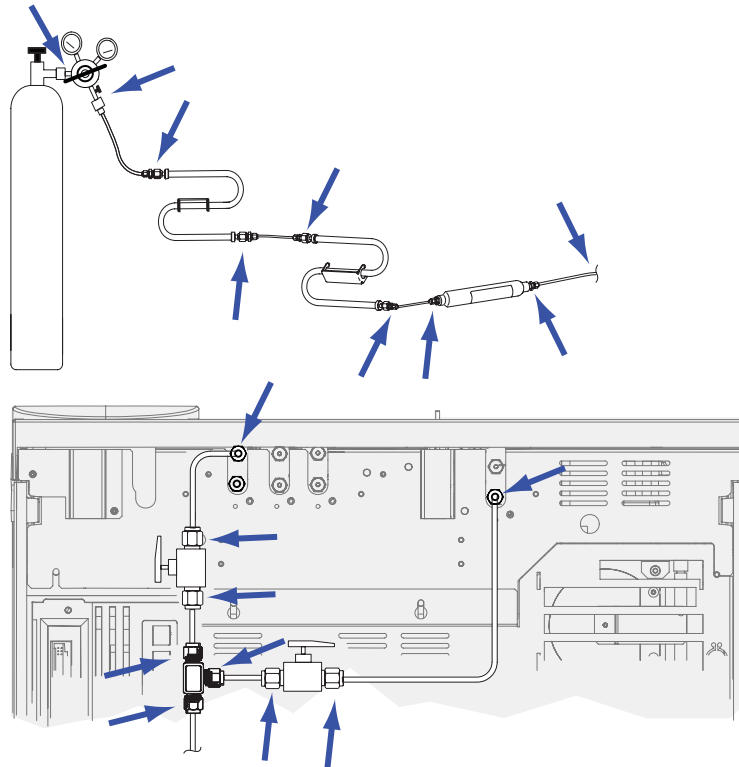

- Gas supply bulkhead fittings
- Gas cylinder fitting
- Regulator fittings
- Traps
- Shut- off valves
- T- fittings

Perform a pressure drop test.

- 1 Turn off the GC.
- 2 Set the regulator pressure to 415 kPa (60 psi).
- 3 Fully turn the regulator knob counterclockwise to shut the valve.
- 4 Wait 5 minutes. If there is a measurable drop in pressure, there is a leak in the external connections. No drop in pressure indicates that the external connections are not leaking.

To Check for GC Leaks

Check for leaks at these connections:

- Inlet septum, septum head, liner, split vent trap, split vent trap line, and purge vent fittings
- Column connections to inlets, detectors, valves, splitters, and unions
- Fittings from the flow modules to the inlets, detectors, and valves
- Column adapters
- Agilent capillary flow fittings

Leaks in Capillary Column (Microfluidic) Fittings

For capillary column fittings, a leak usually indicates that the fitting has been overtightened. Unless the fitting is obviously loose, do not tighten it further. Instead, remove the connection, trim the column end, and install it again.

Also inspect the plate and connection for a broken column tip.

To Perform a SS Inlet Pressure Decay Test

The pressure decay test checks for leaks from the inlet flow module up to the column fitting.

After performing maintenance, first check for leaks in externally accessible areas. See [“To Check for External Leaks”](#).

If a leak is known to exist, check the externally accessible inlet fittings first, especially any connection that has seen recent maintenance, such as the septum nut, column adapter, column connection, and so forth.

The pressure decay leak test described below requires removing the column and capping the inlet column fitting. This test can/cannot find the following types of leaks:

The test can find leaks at the:	The test cannot find leaks at the:
septum	column fitting
septum nut	gas supply bulkhead fittings to the flow module
liner O-ring seal	tubing and connections in a transfer line connected to the inlet
gold seal/washer and reducing nut	internal leaks in an EPC module (septum purge valve)
inlet body	
flow manifold split vent valve	
flow manifold septum purge valve	
split vent tubing and trap	
septum purge tubing	
seals within the tubing between the inlet flow module and the inlet body	

1 Gather the following (see [Consumables and parts for the split/splitless inlet](#)):

- No-hole ferrule
- 1/4-inch wrench
- Heat-resistant gloves (if the inlet is hot)
- Column nut
- New septum

- O- ring
 - ECD/TCD Detector plug (part no. 5060- 9055)
- 2 Load the [inlet maintenance method](#) and wait for the GC to become ready.
 - 3 Remove the column, if installed.
 - 4 Plug the column fitting with a column nut and a no- hole ferrule.
 - 5 Remove the old septum and replace it with a new one. See [To change the septum on the split/splitless inlet](#).
 - 6 Inspect the O- ring and replace it if it is hard and brittle or cracked. See [To change the liner and O- ring on the split/splitless inlet](#).
 - 7 Set the inlet to **Split Mode**.
 - 8 Configure the column as **Inlet: Unspecified**.
 - 9 Set the inlet temperature to 70 °C.
 - 10 Set the **Total flow** to 60 mL/min.
 - 11 Enter a pressure setpoint of 25 psi (172 kPa). Make sure that the pressure supplied to the GC is at least 10 psi (70 kPa) higher than the inlet pressure.
 - 12 If pressure cannot be achieved, there is either a large leak or the supply pressure is too low.
 - 13 Set the **Septum purge** flow to 3.0 mL/min.
 - 14 Cap the septum purge fitting with the ECD/TCD detector plug.

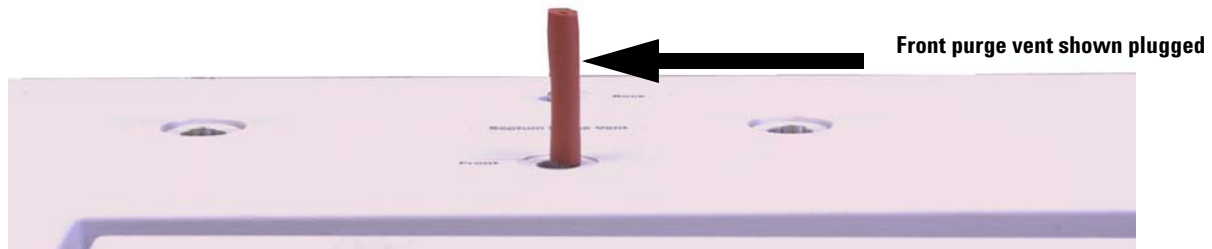
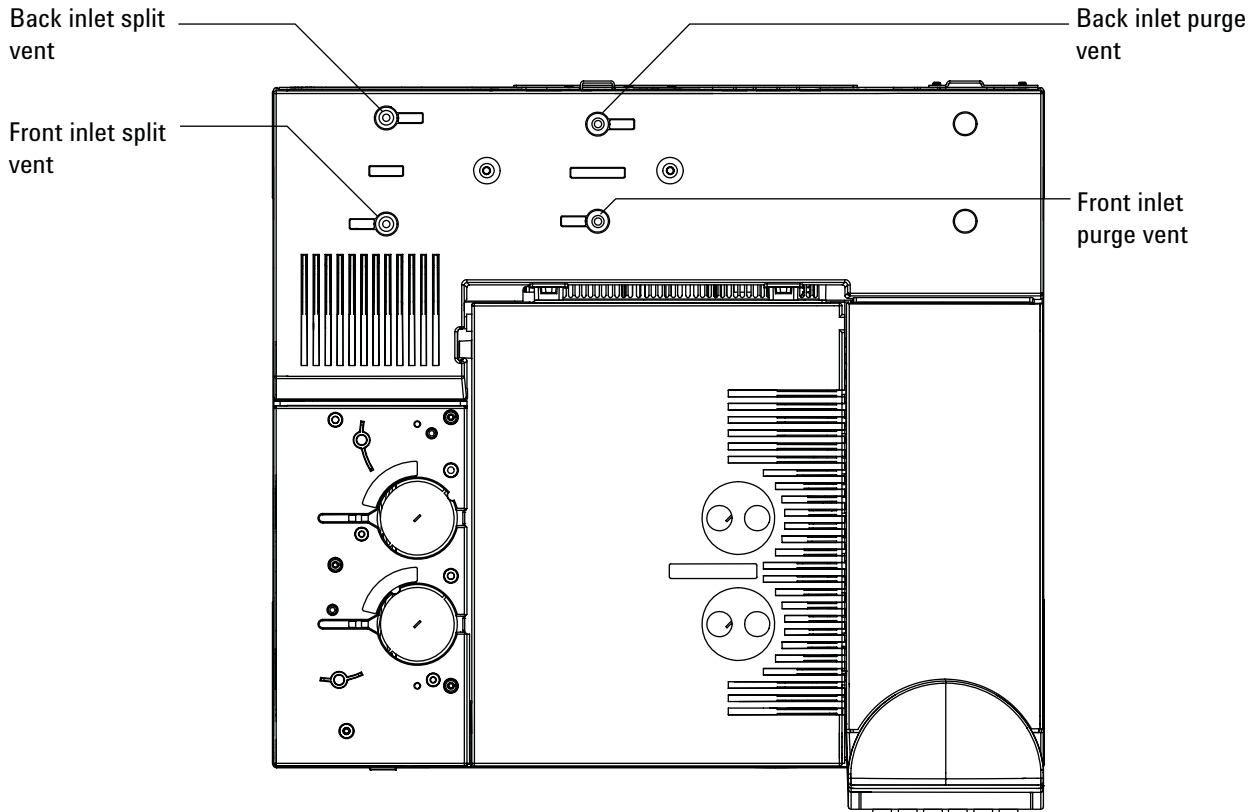

- 15 From the keypad, press [**Service Mode**]. Select **Diagnostics > Front or Back Inlet > Pneumatics Control > Septum Purge control**.
- 16 Scroll to the **Constant duty cycle** and enter **50**. Wait 10 seconds.
- 17 Press [**Front or Back Inlet**]. Scroll to **Pressure** and press **Off/No**.
- 18 Quickly turn off the carrier gas supply at its source.
- 19 Monitor the pressure for 10 minutes. Use the timer by pressing [**Time**] and [**Enter**].

A pressure drop of less than 0.5 psig (0.05 psi/min or less; 3.4 kPa or 0.34 kPa/min) is acceptable.

If the pressure drops much faster than the acceptable rate, see [“To Correct Leaks in the Split Splitless Inlet”](#). Retest.

Note that liner size impacts pressure drop. An inlet with a smaller volume liner does not tolerate as large a leak rate as an inlet with a larger volume liner.

- 20 After the inlet passes the test, restore the GC to operating condition.
 - Remove any caps/plugs.
 - Reinstall the column.
 - Restore the correct column configuration.
 - Load the operating method.

To Correct Leaks in the Split Splitless Inlet

If the inlet fails a pressure decay test, check the following:

- Check the caps/plugs used in the test—make sure each is correctly installed and tight.
- If you performed the leak test after performing maintenance, check for proper installation of the part(s) handled during the maintenance.
- Check the tightness of the septum nut. See [To change the septum on the split/Splitless inlet](#).
- Check the septum. Replace if old or damaged.
- Check the insert assembly installation.
- Check the liner and liner O- ring. See [To change the liner and O- ring on the split/splitless inlet](#).
- If you changed the gold seal, verify correct installation. See [To replace the gold seal on the split/splitless inlet](#).

If these items do not resolve the problem, contact Agilent for service.

To Perform a Multimode Inlet Pressure Decay Test

The pressure decay test checks for leaks from the inlet flow module up to the column fitting.

After performing maintenance, first check for leaks in externally accessible areas. See [“To Check for External Leaks”](#).

If a leak is known to exist, check the externally accessible inlet fittings first, especially any connection that has seen recent maintenance, such as the septum nut, column adapter, column connection, and so forth.

The pressure decay leak test described below requires removing the column and capping the inlet column fitting. This test can/cannot find the following types of leaks:

The test can find leaks at the:	The test cannot find leaks at the:
septum	column fitting
septum nut	gas supply bulkhead fittings to the flow module
liner O-ring seal	tubing and connections in a transfer line connected to the inlet
inlet body	
flow manifold split vent valve	
flow manifold septum purge valve	
split vent tubing and trap	
septum purge tubing	
seals within the tubing between the inlet flow module and the inlet body	

1 Gather the following (see [Consumables and parts for the Multimode inlet](#)):

- No-hole ferrule
- 1/4-inch wrench
- Heat-resistant gloves (if the inlet is hot)
- Column nut
- New septum
- O-ring
- ECD/TCD Detector plug (part no. 5060-9055)

- 2 Load the [inlet maintenance method](#) and wait for the GC to become ready.
- 3 Remove the column, if installed.
- 4 Plug the column fitting with a column nut and a no-hole ferrule.
- 5 Remove the old septum and replace it with a new one. See [To change the septum on the multimode inlet](#).
- 6 Inspect the O-ring and replace it if it is hard and brittle or cracked. See [To change the liner and O-ring on the Multimode inlet](#).
- 7 Set the inlet to **Split Mode**.
- 8 Configure the column as **Inlet: Unspecified**.
- 9 Set the inlet temperature to 70 °C.
- 10 Set the **Total flow** to 60 mL/min.
- 11 Enter a pressure setpoint of 25 psi (172 kPa). Make sure that the pressure supplied to the GC is at least 10 psi (70 kPa) higher than the inlet pressure.
- 12 If pressure cannot be achieved, there is either a large leak or the supply pressure is too low.
- 13 Set the **Septum purge** flow to 3.0 mL/min.
- 14 Cap the septum purge fitting with the ECD/TCD detector plug.

6 Checking for Leaks

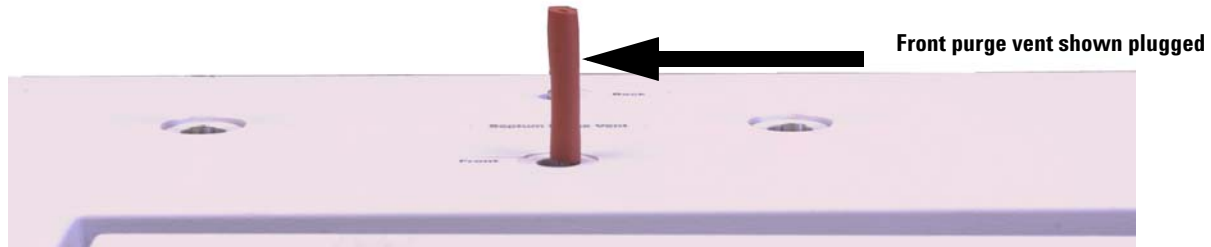
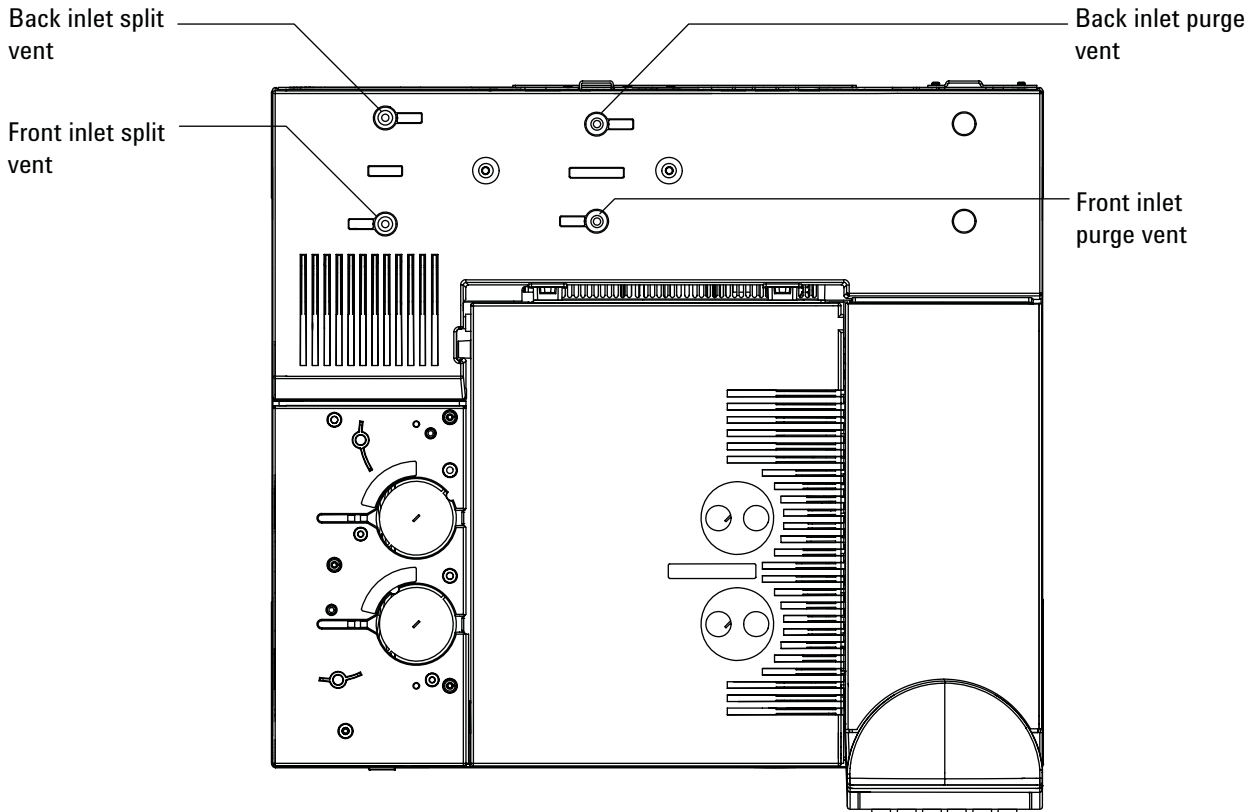

- 15 From the keypad, press [**Service Mode**]. Select **Diagnostics > Front or Back Inlet > Pneumatics Control > Septum Purge control**.
- 16 Scroll to the **Constant duty cycle** and enter **50**. Wait 10 seconds.
- 17 Press [**Front or Back Inlet**]. Scroll to **Pressure** and press **Off/No**.
- 18 Quickly turn off the carrier gas supply at its source.
- 19 Monitor the pressure for 10 minutes. Use the timer by pressing [**Time**] and [**Enter**].

A pressure drop of less than 0.5 psig (0.05 psi/min or less; 3.4 kPa or 0.34 kPa/min) is acceptable.

If the pressure drops much faster than the acceptable rate, see [“To Correct Leaks in the Multimode Inlet”](#). Retest.

Note that liner size impacts pressure drop. An inlet with a smaller volume liner does not tolerate as large a leak rate as an inlet with a larger volume liner.

- 20 After the inlet passes the test, restore the GC to operating condition.
 - Remove any caps/plugs.
 - Reinstall the column.
 - Restore the correct column configuration.
 - Load the operating method.

To Correct Leaks in the Multimode Inlet

If the inlet fails a pressure decay test, check the following:

- Check the caps/plugs used in the test—make sure each is correctly installed and tight.
- If you performed the leak test after performing maintenance, check for proper installation of the part(s) handled during the maintenance.
- Check the tightness of the septum nut. See [To change the septum on the Multimode inlet](#).
- Check the septum. Replace if old or damaged.
- Check the insert assembly installation.
- Check the liner and liner O- ring. See [To change the liner and O- ring on the Multimode inlet](#).

If these items do not resolve the problem, contact Agilent for service.

To Perform a PP Inlet Pressure Decay Test

The pressure decay test checks for leaks from the inlet flow module up to the column fitting.

After performing maintenance, first check for leaks in externally accessible areas. See [“To Check for External Leaks”](#).

If a leak is known to exist, check the externally accessible inlet fittings first, especially any connection that has seen recent maintenance, such as the septum nut, column adapter, column connection, and so forth.

The pressure decay leak test described below requires removing the column and capping the inlet column fitting. This test can/cannot find the following types of leaks:

The test can find leaks at the:	The test cannot find leaks at the:
septum	column fitting
septum nut	gas supply bulkhead fittings to the flow module
glass insert O-ring seal	
adapter and ferrule	
inlet body	
top insert weldment	
seals within the tubing between the inlet flow module and the inlet body	

- 1 Gather the following (see [Consumables and parts for the purged packed inlet](#)):
 - No-hole ferrule
 - 1/4-inch wrench
 - 7/16-inch wrench
 - Heat-resistant gloves (if the inlet is hot)
 - 9/16-inch wrench
 - 1/8- and 1/4-inch Swagelok caps
 - ECD/TCD Detector plug (part no. 5060-9055)
- 2 Load the [inlet maintenance method](#) and wait for the GC to become ready.
- 3 Remove the column, if installed.

- 4 Plug the column fitting.
 - If the capillary column adapter is installed, use a column nut and a no-hole ferrule
 - If a 1/8-inch packed column adapter is installed, use a 1/8-inch Swagelok cap (5180-4121).
 - If a 1/4-inch packed column adapter is installed, use a 1/4-inch Swagelok cap (5180-4120)
- 5 Remove the old septum and replace it with a new one. See [To change the septum on the purged packed inlet](#).
- 6 Inspect the O-ring and replace it if it is hard and brittle or cracked. See [To change the O-ring on the purged packed inlet](#).
- 7 If unsure of the quality of the adapter ferrule, replace it. See [To change the glass insert on a PP inlet](#).
- 8 Configure, but do not install, a capillary column to put the inlet in pressure control mode.
- 9 Set the inlet temperature to 100 °C.
- 10 Enter a pressure setpoint of 25 psi (172 kPa). Make sure that the pressure supplied to the GC is at least 10 psi (70 kPa) higher than the inlet pressure.
- 11 If pressure cannot be achieved, there is either a large leak or the supply pressure is too low.
- 12 Set the **Septum purge** flow to 3.0 mL/min.
- 13 Cap the septum purge fitting with the ECD/TCD detector plug.

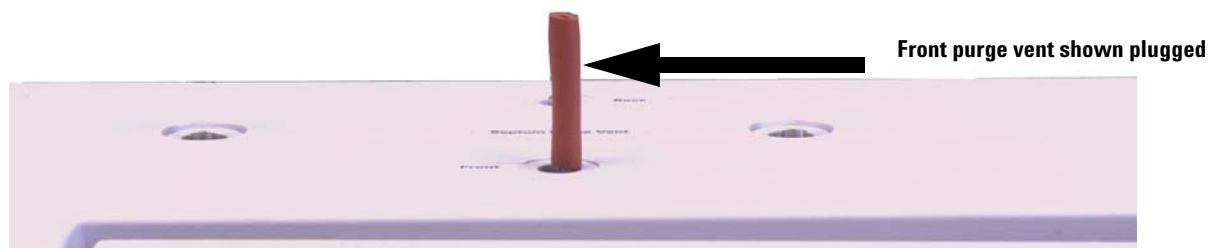
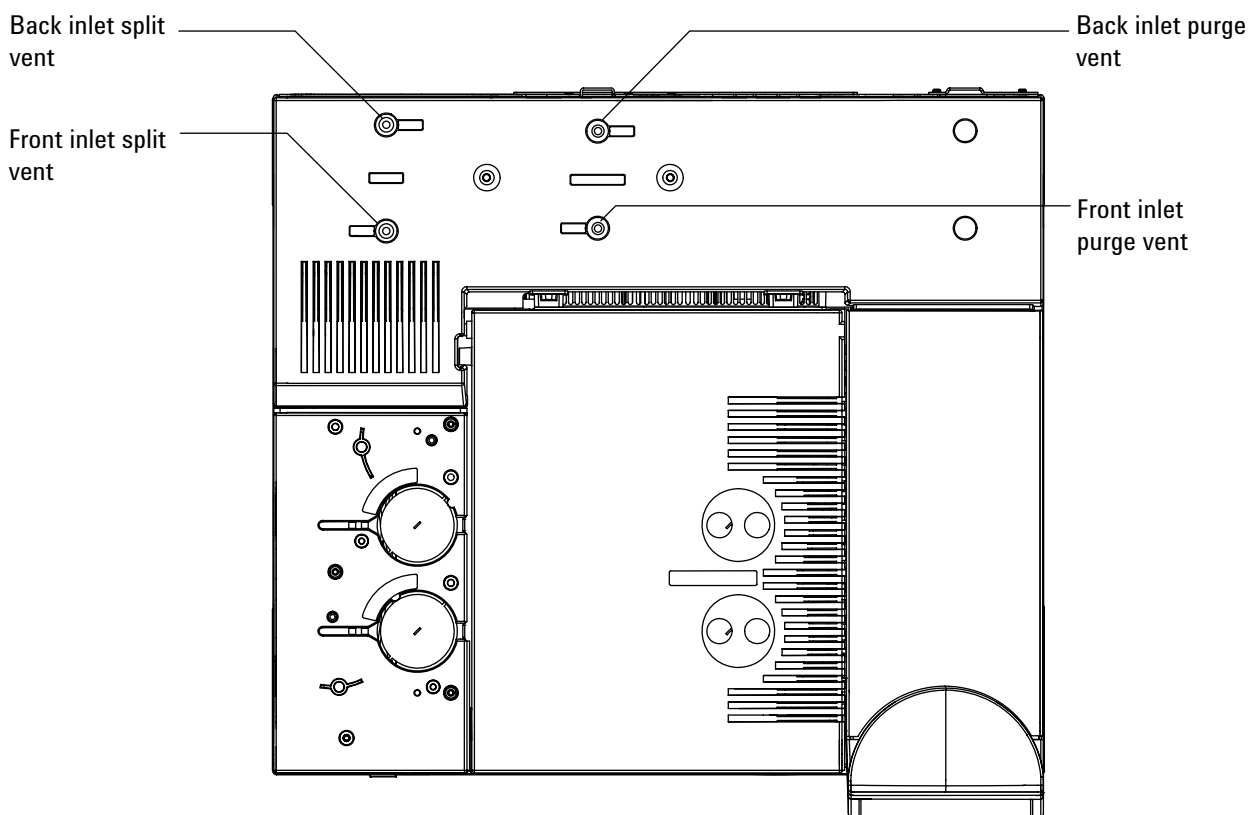

- 14 From the keypad, press [**Service Mode**]. Select **Diagnostics > Front or Back Inlet > Pneumatics Control > Septum Purge control**.
- 15 Scroll to the **Constant duty cycle** and enter **50**. Wait 10 seconds.
- 16 Press [**Front or Back Inlet**]. Scroll to **Pressure** and press **Off/No**.
- 17 Quickly turn off the carrier gas supply at its source.
- 18 Monitor the pressure for 10 minutes. Use the timer by pressing [**Time**] and [**Enter**].

A pressure drop of less than 0.7 psig (0.07 psi/min or less; 4.8 kPa or 0.48 kPa/min) is acceptable.

If the pressure drops much faster than the acceptable rate, see [“To Correct Leaks in the Packed Column Inlet”](#). Retest.

- 19 After the inlet passes the test, restore the GC to operating condition.
 - Remove any caps/plugs.
 - Reinstall the column.
 - Restore the correct column configuration.
 - Load the operating method.

To Correct Leaks in the Packed Column Inlet

If the inlet fails a pressure decay test, check the following:

- Check the caps/plugs used in the test—make sure each is correctly installed and tight.
- If you performed the leak test after performing maintenance, check for proper installation of the part(s) handled during the maintenance.
- Check the tightness of the septum nut. See [To change the septum on the purged packed inlet](#).
- Check the septum. Replace if old or damaged.
- Check that the top insert weldment is installed tightly.
- Replace the O- ring. See [To change the O- ring on the purged packed inlet](#). Also check the glass insert. See [To change the glass insert on a PP inlet](#).
- Replace the ferrule seal on the adapter.

If these items do not resolve the problem, contact Agilent for service.

To Perform a COC Pressure Decay Test

The pressure decay test checks for leaks from the inlet flow module up to the column fitting.

After performing maintenance, first check for leaks in externally accessible areas. See [“To Check for External Leaks”](#).

If a leak is known to exist, check the externally accessible inlet fittings first, especially any connection that has seen recent maintenance, such as the septum nut, column adapter, column connection, and so forth. See [“To Check for External Leaks”](#).

The pressure decay leak test described below requires removing the column and capping the inlet column fitting. This test can/cannot find the following types of leaks:

The test can find leaks at the:	The test cannot find leaks at the:
septum	column fitting
septum nut or cooling tower	gas supply bulkhead fittings to the flow module
seals within the tubing between the inlet flow module and the inlet body	
inlet body	

- 1 Gather the following (see [Consumables and parts for the COC inlet](#)):
 - No-hole ferrule
 - 1/4-inch wrench
 - Heat-resistant gloves (if the inlet is hot)
 - Column nut
 - New septum
 - ECD/TCD Detector plug (part no. 5060-9055)
- 2 Load the [inlet maintenance method](#) and wait for the GC to become ready.
- 3 Remove the column, if installed.
- 4 Plug the column fitting with a column nut and no-hole ferrule.
- 5 Remove the old septum and replace it with a new one. See [To change a septum on the COC inlet](#).

- 6 Enter a pressure setpoint of 25 psi (172 kPa). Make sure that the pressure supplied to the GC is at least 10 psi (70 kPa) higher than the inlet pressure.
- 7 Wait 5 minutes for the pressure to equilibrate. If pressure cannot be achieved, there is either a large leak or the supply pressure is too low.
- 8 Set the **Septum purge** flow to 3.0 mL/min.
- 9 Cap the septum purge fitting with the ECD/TCD detector plug.

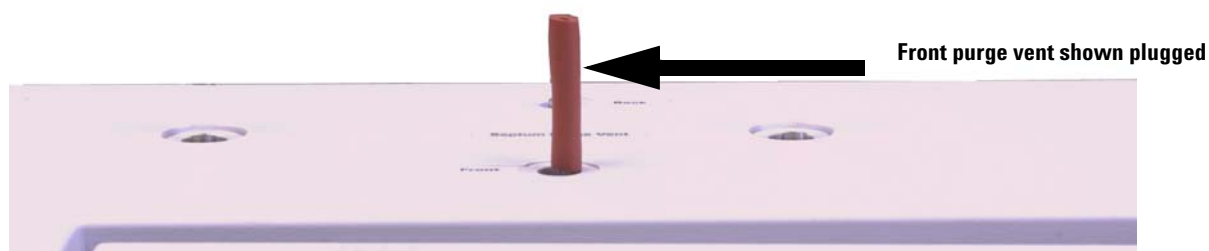
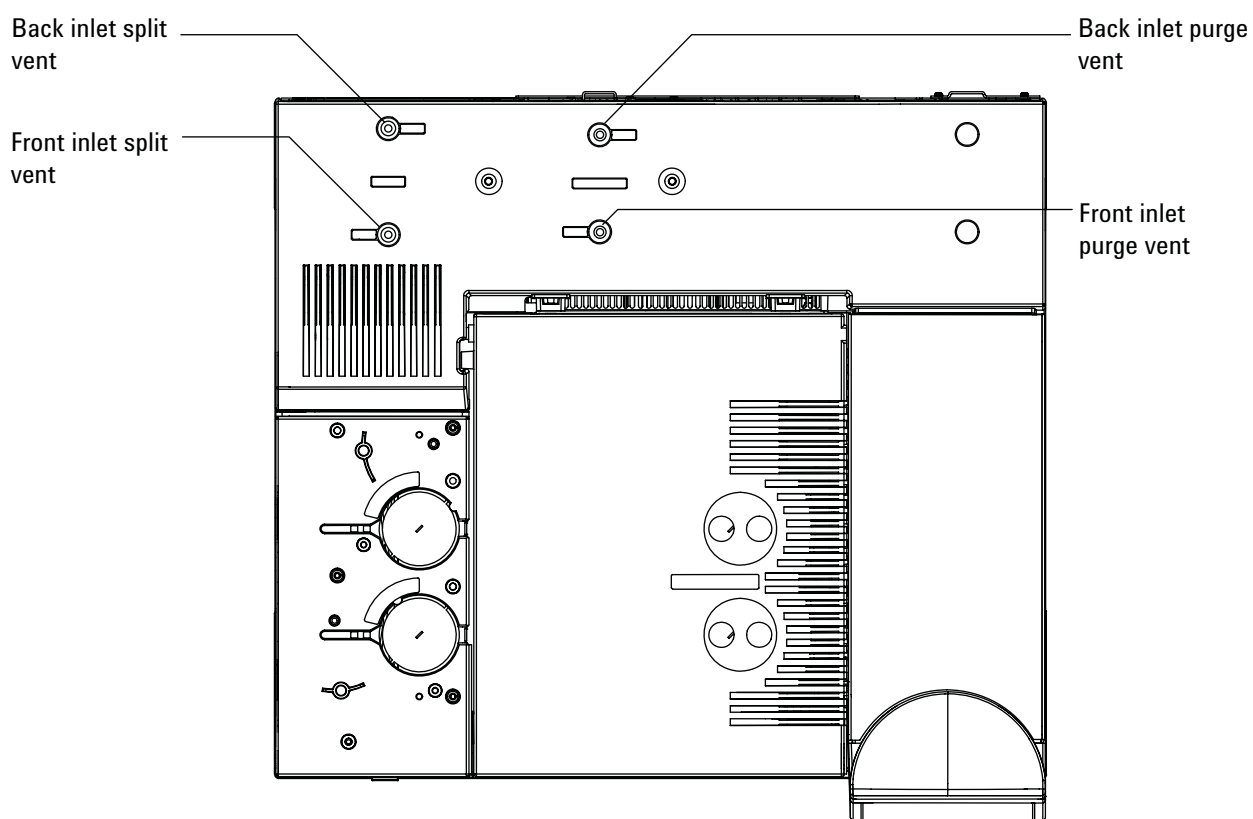

- 10 From the keypad, press [**Service Mode**]. Select **Diagnostics > Front or Back Inlet > Pneumatics Control > Septum Purge control**.

- 11 Scroll to the **Constant duty cycle** and enter **50**. Wait 10 seconds.
- 12 Press [**Front or Back Inlet**]. Scroll to **Pressure** and press **Off/No.**
- 13 Quickly turn off the carrier gas supply at its source.
- 14 Monitor the pressure for 10 minutes. Use the timer by pressing [**Time**] and [**Enter**].

A pressure drop of less than 1.0 psig (0.1 psi/min or less; 6.9 kPa or 0.69 kPa/min) is acceptable.

If the pressure drops much faster than the acceptable rate, see [“To Correct Leaks in the Cool On- Column Inlet”](#). Retest.

- 15 After the inlet passes the test, restore the GC to operating condition.
 - Remove any caps/plugs.
 - Reinstall the column.
 - Restore the correct column configuration.
 - Load the operating method.

To Correct Leaks in the Cool On-Column Inlet

If the inlet fails a pressure decay test, check the following:

- Check the caps/plugs used in the test—make sure each is correctly installed and tight.
- If you performed the leak test after performing maintenance, check for proper installation of the part(s) handled during the maintenance.
- Check the tightness of the septum nut or cooling tower assembly. See [To change a septum nut or cooling tower and septum on a COC inlet](#).
- Check the septum. Replace if old or damaged.

If these items do not resolve the problem, contact Agilent for service.

To Perform a PTV Pressure Decay Test

The pressure decay test checks for leaks from the inlet flow module up to the column fitting.

After performing maintenance, first check for leaks in externally accessible areas. See [“To Check for External Leaks”](#).

If a leak is known to exist, check the externally accessible inlet fittings first, especially any connection that has seen recent maintenance, such as the septum nut, column adapter, column connection, and so forth.

The pressure decay leak test described below requires removing the column and capping the inlet column fitting. This test can/cannot find the following types of leaks:

The test can find leaks at the:	The test cannot find leaks at the:
septum	column fitting
septum nut	gas supply bulkhead fittings to the flow module
liner O-ring seal	tubing and connections in a transfer line connected to the inlet
gold seal/washer and reducing nut	
inlet body	
flow manifold split vent valve	
flow manifold septum purge valve	
split vent tubing and trap	
septum purge tubing	
seals within the tubing between the inlet flow module and the inlet body	

1 Gather the following (see [Consumables and parts for the PTV inlet](#)):

- No-hole ferrule
- 1/4-inch wrench
- Heat-resistant gloves (if the inlet is hot)
- Column nut
- New septum
- New Graphpak 3D ferrule and liner

- ECD/TCD Detector plug (part no. 5060-9055)
- 2 Load the [inlet maintenance method](#) and wait for the GC to become ready.
 - 3 Remove the column, if installed.
 - 4 Plug the column fitting with a column nut and a no-hole ferrule.
 - 5 If using the septum head, and the quality of the septum (or Microseal) and GRAPHPACK-3D ferrule on the glass liner are unknown, replace them now. See [To change the septum on the PTV inlet](#) and [To change the liner on the PTV inlet](#).
 - 6 Set the inlet to **Split Mode**.
 - 7 Configure the column as 0 length.
 - 8 Set the inlet temperature to 100 °C.
 - 9 Set the **Total flow** to 60 mL/min.
 - 10 Enter a pressure setpoint of 25 psi (172 kPa). Make sure that the pressure supplied to the GC is at least 10 psi (70 kPa) higher than the inlet pressure.
 - 11 If pressure cannot be achieved, there is either a large leak or the supply pressure is too low.
 - 12 Set the **Septum purge** flow to 3.0 mL/min.
 - 13 Cap the septum purge fitting with the ECD/TCD detector plug.

6 Checking for Leaks

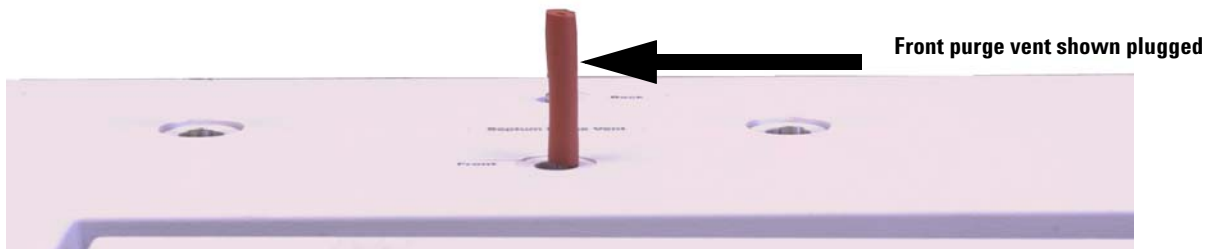
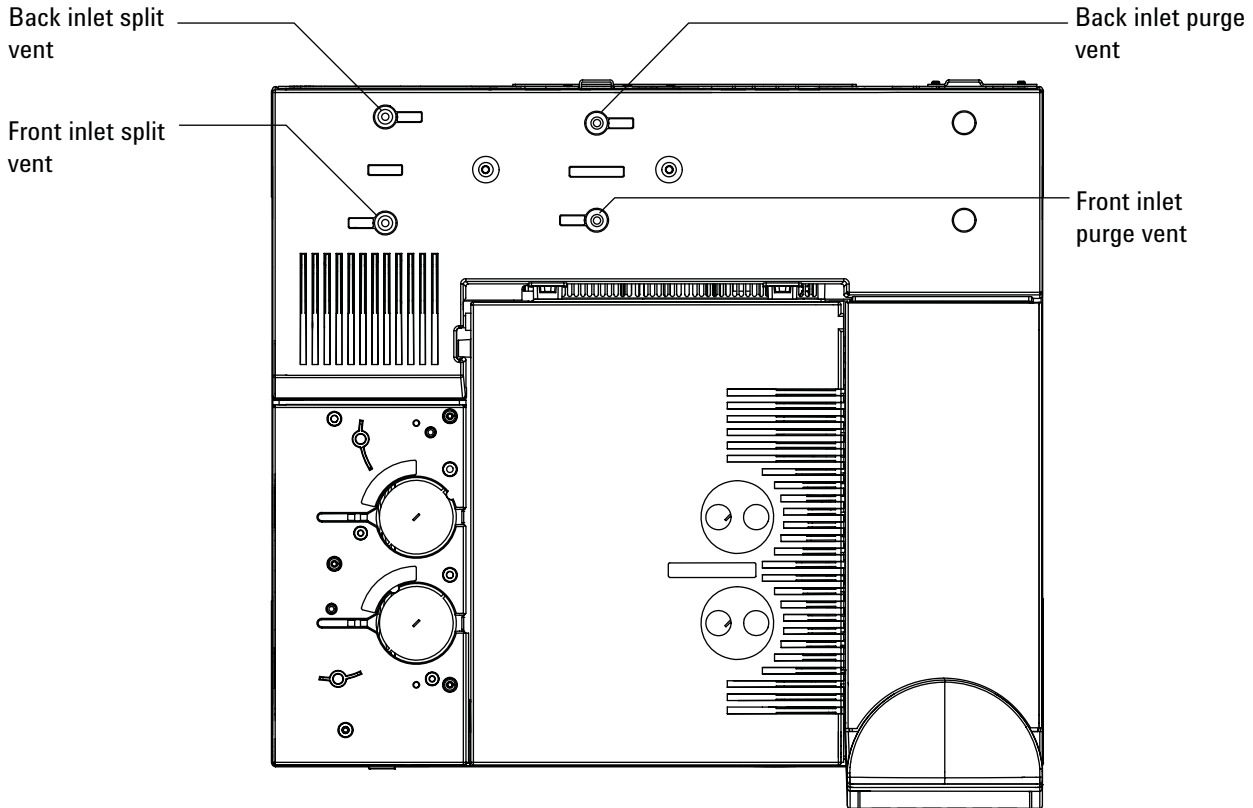

- 14 From the keypad, press [**Service Mode**]. Select **Diagnostics > Front or Back Inlet > Pneumatics Control > Septum Purge control**.
- 15 Scroll to the **Constant duty cycle** and enter **50**. Wait 10 seconds.
- 16 Press [**Front or Back Inlet**]. Scroll to **Pressure** and press **Off/No**.
- 17 Quickly turn off the carrier gas supply at its source.
- 18 Monitor the pressure for 10 minutes. Use the timer by pressing [**Time**] and [**Enter**].

A pressure drop of less than 0.5 psig (0.05 psi/min or less; 3.4 kPa or 0.34 kPa/min) is acceptable.

If the pressure drops much faster than the acceptable rate, see [“To Correct Leaks in the PTV Inlet”](#). Retest.

Note that liner size impacts pressure drop. An inlet with a smaller volume liner does not tolerate as large a leak rate as an inlet with a larger volume liner.

- 19 After the inlet passes the test, restore the GC to operating condition.
 - Remove any caps/plugs.
 - Reinstall the column.
 - Restore the correct column configuration.
 - Load the operating method.

To Correct Leaks in the PTV Inlet

If the inlet fails a pressure decay test, check the following:

- Check the caps/plugs used in the test—make sure each is correctly installed and tight.
- If you performed the leak test after performing maintenance, check for proper installation of the part(s) handled during the maintenance.
- If using a septum head, check the tightness of the septum nut. See [To change the septum on the PTV inlet](#).
- If using a septum head, check the septum. Replace if old or damaged.
- Check that the septumless- or septum- head assembly is installed tightly.
- Replace the liner and Graphpak 3D ferrule. See [To change the liner on the PTV inlet](#).
- Check the Graphpak adapter seal against the inlet body. Replace the silver seal and reinstall the adapter if needed. See [To replace the inlet adapter for the PTV inlet](#).
- If using the septumless head, check for leaks around the guide cap. Replace the Teflon ferrule in the guide cap. See [To replace the Teflon ferrule on a PTV inlet](#).
- Check for leaks at the split vent trap. Tighten as necessary. Replace the split vent trap filter and O- rings. See [To replace the filter in the PTV inlet split vent line](#).

If these items not resolve the problem, contact Agilent for service.

To Perform a VI Pressure Decay Test

The pressure decay test checks for leaks from the inlet flow module up to the column fitting.

Initially test the VI with a sampling system installed. If the system fails the leak test, then isolate the VI from the sampler as described in [“To Prepare the VI for a Closed System Leak Check”](#) on page 150.

After performing maintenance, first check for leaks in externally accessible areas. See [“To Check for External Leaks”](#).

If a leak is known to exist, check the externally accessible inlet fittings first, especially any connection that has seen recent maintenance, such as the column connection, split vent line, and so forth.

The pressure decay leak test described below requires removing the column and capping the inlet column fitting. This test can/cannot find the following types of leaks:

The test can find leaks at the:	The test cannot find leaks at the:
sampler connection	column fitting
pressure sensing line connection to the interface	gas supply bulkhead fittings to the flow module
split vent line connection to the interface	tubing and connections in a transfer line connected to the inlet
the connected sampler’s entire sample flow path	
flow manifold split vent valve	
flow manifold septum purge valve	
split vent tubing and trap	

- Gather the following (see [Consumables and parts for the VI](#)):
 - No-hole ferrule
 - 1/4-inch wrench
 - Heat-resistant gloves (if the inlet is hot)
 - Long column nut
 - ECD/TCD Detector plug (part no. 5060-9055)
- Load the [inlet maintenance method](#) and wait for the GC to become ready.

6 Checking for Leaks

- 3 Remove the column, if installed.
- 4 Plug the column fitting with a column nut and a no-hole ferrule.
- 5 Set the inlet to **Split Mode**.
- 6 Configure the column as 0 length.
- 7 Set the inlet temperature to 100 °C.
- 8 Set the **Total flow** to 60 mL/min.
- 9 Enter a pressure setpoint of 25 psi (172 kPa). Make sure that the pressure supplied to the GC is at least 10 psi (70 kPa) higher than the inlet pressure.
- 10 If pressure cannot be achieved, there is either a large leak or the supply pressure is too low.
- 11 Set the **Septum purge** flow to 3.0 mL/min.
- 12 Cap the septum purge fitting with the ECD/TCD detector plug.

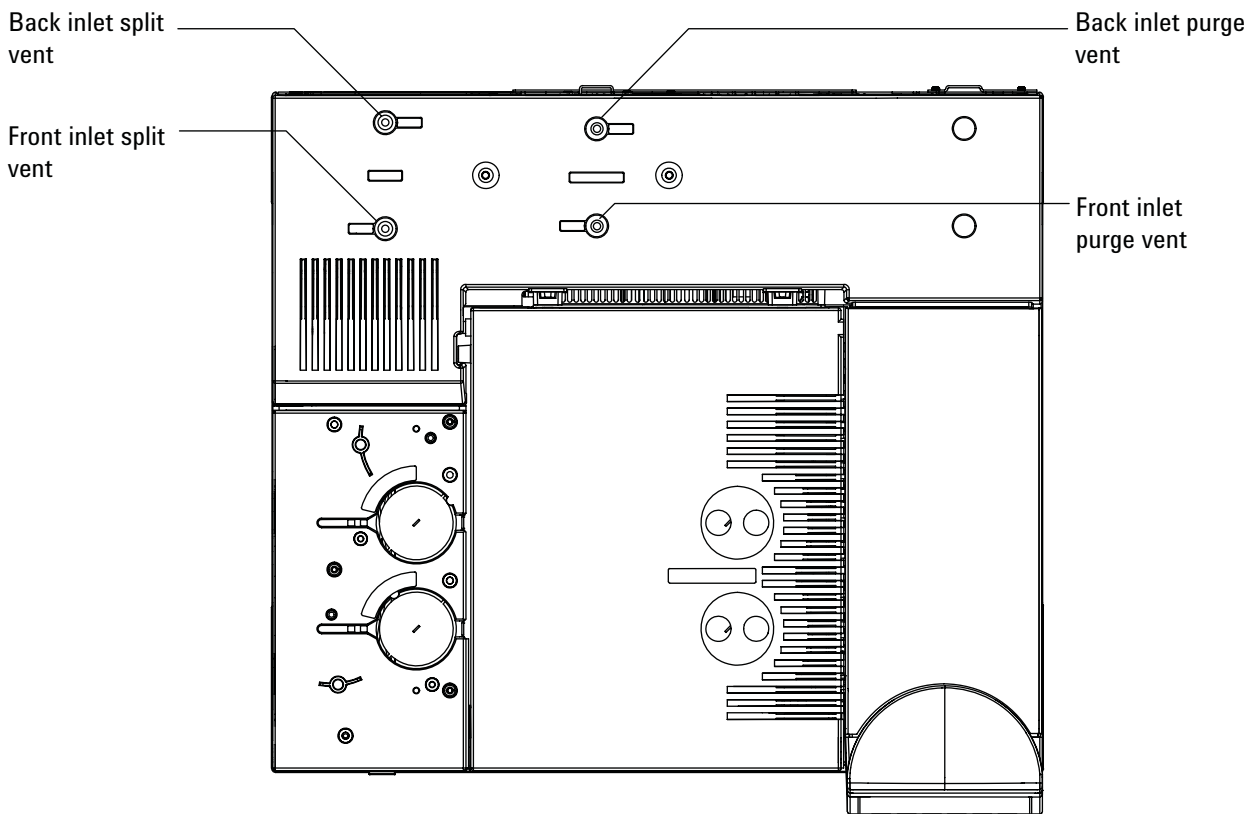

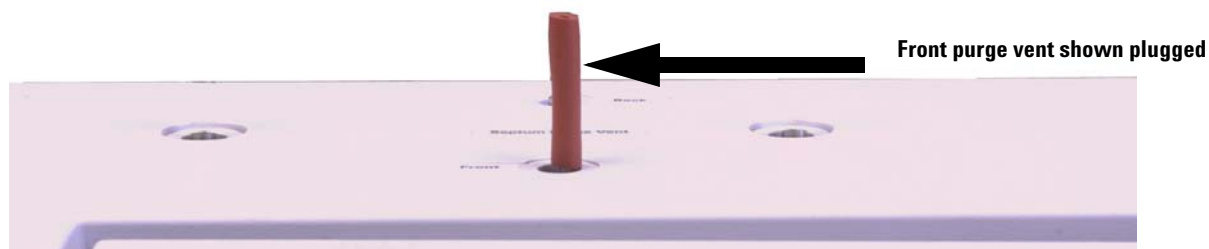

- 13 From the keypad, press **[Service Mode]**. Select **Diagnostics > Front or Back Inlet > Pneumatics Control > Septum Purge control**.
- 14 Scroll to the **Constant duty cycle** and enter **50**. Wait 10 seconds.
- 15 Press **[Front or Back Inlet]**. Scroll to **Pressure** and press **Off/No.**
- 16 Quickly turn off the carrier gas supply at its source.
- 17 Monitor the pressure for 10–15 minutes. Use the timer by pressing **[Time]** and **[Enter]**.

The pressure should drop approximately 1 psi (6.9 kPa) during the first 1 to 2 minutes. After an initial pressure drop of about 1 psi, the pressure should not drop more than 0.03 psi/min (0.21 kPa/min).

If the pressure drop is 0.03 psi/min or less, you can consider the interface- gas sampler system leak- free.

If the pressure drops faster than the acceptable rate, you must check the interface and sampler systems separately to determine the source of the leak. See [“To Prepare the VI for a Closed System Leak Check”](#) to create a closed flow system, then return to this section and complete steps 10 to 15.

If you find a leak in the interface, refer to [“To Correct Leaks in the Volatiles Interface”](#).

If the interface is leak- free, pressure check the sampling device. See the operating manual for your sampler for instructions.

- 18 After the VI passes the test, restore the GC to operating condition.
 - Remove any caps/plugs.
 - If needed, reconnect the sampling device.
 - Reinstall the column.
 - Restore the correct column configuration.
 - Load the operating method.

To Prepare the VI for a Closed System Leak Check

To leak check the interface independently of the gas sampling device, you must disconnect the sampler from the interface to isolate the interface flow system from the sampler.

WARNING

Be careful! The oven and/or inlet may be hot enough to cause burns. If either is hot, wear heat-resistant gloves to protect your hands.

- 1 Gather the following:
 - 1/16- inch nut for transfer line
 - Ferrule for transfer line
 - Heat- resistant gloves (if the inlet is hot)
- 2 Disconnect the transfer line from the interface.
- 3 Disconnect the carrier line from the sampler.
- 4 Prepare the end of the carrier line using a 1/16- inch male nut and ferrule.
- 5 Connect the carrier line to the interface where you removed the transfer line and tighten the nut finger tight. Tighten an additional 1/4 to 1/2 turn with the 1/4- inch wrench.
- 6 Return to [“To Perform a VI Pressure Decay Test”](#) and repeat steps 9 to 15.

To Correct Leaks in the Volatiles Interface

If the inlet fails a pressure decay test, check the following:

- The caps and plugs used in the test—make sure each is correctly installed and tight.
- If you performed the leak test after performing maintenance, check for proper installation of the part(s) handled during the maintenance.
- The split vent and pressure sensing connections at the interface.
- The sampler connection to the interface.
- The sampler.

If these items do not resolve the problem, contact Agilent for service.

6 Checking for Leaks



7 Flow and Pressure Modules

About Flow and Pressure Control	154
Maximum operating pressure	154
PIDs	155
Inlet Modules	156
Detector Modules	157
Pressure Control Modules	158
Auxiliary Pressure Controllers	161
Restrictors	162
1. Using an Aux epc channel to supply purge gas to a splitter	163
2. Using the PCM channels	163

About Flow and Pressure Control

The GC uses four types of electronic flow or pressure controllers; inlet modules, detector modules, pressure control modules (PCMs), and auxiliary pressure controllers (Aux EPCs).

All of these modules mount in the slots at the top rear of the GC. The slots are identified by numbers, as shown here.

			Split vent traps and valves
Slot 5	Slot 3	Slot 1	
Slot 6	Slot 4	Slot 2	

Back of GC

When a module is installed in a slot, it must be connected to the communications buss that runs underneath it. Each branch of the buss has an identifying label near the connector. The proper branch must be connected to the module for the firmware to recognize it.

Branch/slot assignments are:

			Split vent traps and valves
EPC5	EPC3	EPC1	
EPC6	EPC4	EPC2	

Back of GC

If a detector is mounted in the left side carrier (as seen from the front side of the oven), it is controlled by **EPC6**. An extension cable connects to **EPC6**, runs across the top of the oven just in front of the top row of slots, and passes through an opening into the detector carrier.

Maximum operating pressure

The pneumatics modules of the GC will stand over 250 psi pressure, but may not function reliably. We recommend a maximum continuous operating pressure of 170 psi to avoid excessive wear and leaks.

PIDs

The behavior of a pressure control module is governed by a set of three constants, called **P** (proportional), **I** (integral), and **D** (differential).

Certain gases or special applications (such as QuickSwap, headspace vial pressurization, or splitter and backflush applications) require different PIDs than those provided at the factory.

If you need to update or change the pneumatic PID values for an application, use the utility program on the documentation and utility DVD provided with the GC.

The table summarizes custom PID values required for selected applications. Note that if you are updating an AUX EPC module, you will need to change the frit for the channel used.

Table 23 PIDs and frits

Application	Module	AUX frit	Select Available PID Values
QuickSwap	AUX EPC	Brown, 1 ring	Quickswap
Purged splitter and Deans Switch when using backflush	AUX EPC	No color or rings	Quickswap
Purged splitter and Deans Switch	AUX EPC	Brown, 1 ring	Standard
Headspace vial pressurization	AUX EPC	No color or rings	AUX_EPC_Headspace
Headspace sampling loop	PCM in backpressure control		PCM_Headspace

Inlet Modules

These modules are used with specific inlets. They provide a controlled flow or pressure of carrier gas to the inlet and control the septum flow rate.

Module locations depend on the type of module and the length of the tubing connecting it to the inlet.

If you have a **Front inlet**, its flow module must go in Slot 1.

If you have a **Back inlet**, its flow module must go in Slot 2.

Detector Modules

These are specific to the detector with which they are supplied, and differ according to the needs of that detector. For example, the FID module must supply controlled amounts of air, hydrogen, and makeup gas. The TCD module supplies the reference and makeup gases, but includes the reference switching valve that is essential to detector operation.

Module locations depend on the type of module and the length of the tubing connecting it to the detector.

If you have a **Front detector**, its flow module must go in Slot 3.

If you have a **Back detector**, its flow module must go in Slot 4.

If you have a TCD detector mounted on the left side of the GC, its flow module mounts in a special bracket near the detector.

Pressure Control Modules

The PCM is a general purpose module with two independent control channels, designated 1 and 2. The general name of a PCM module is **PCM #**, where the # (actually, a letter) identifies the PCM (there can be up to 3 installed).

The two channels are not identical. Channel 1 is a simple forward- pressure regulated channel that maintains constant flow through a fixed restrictor.

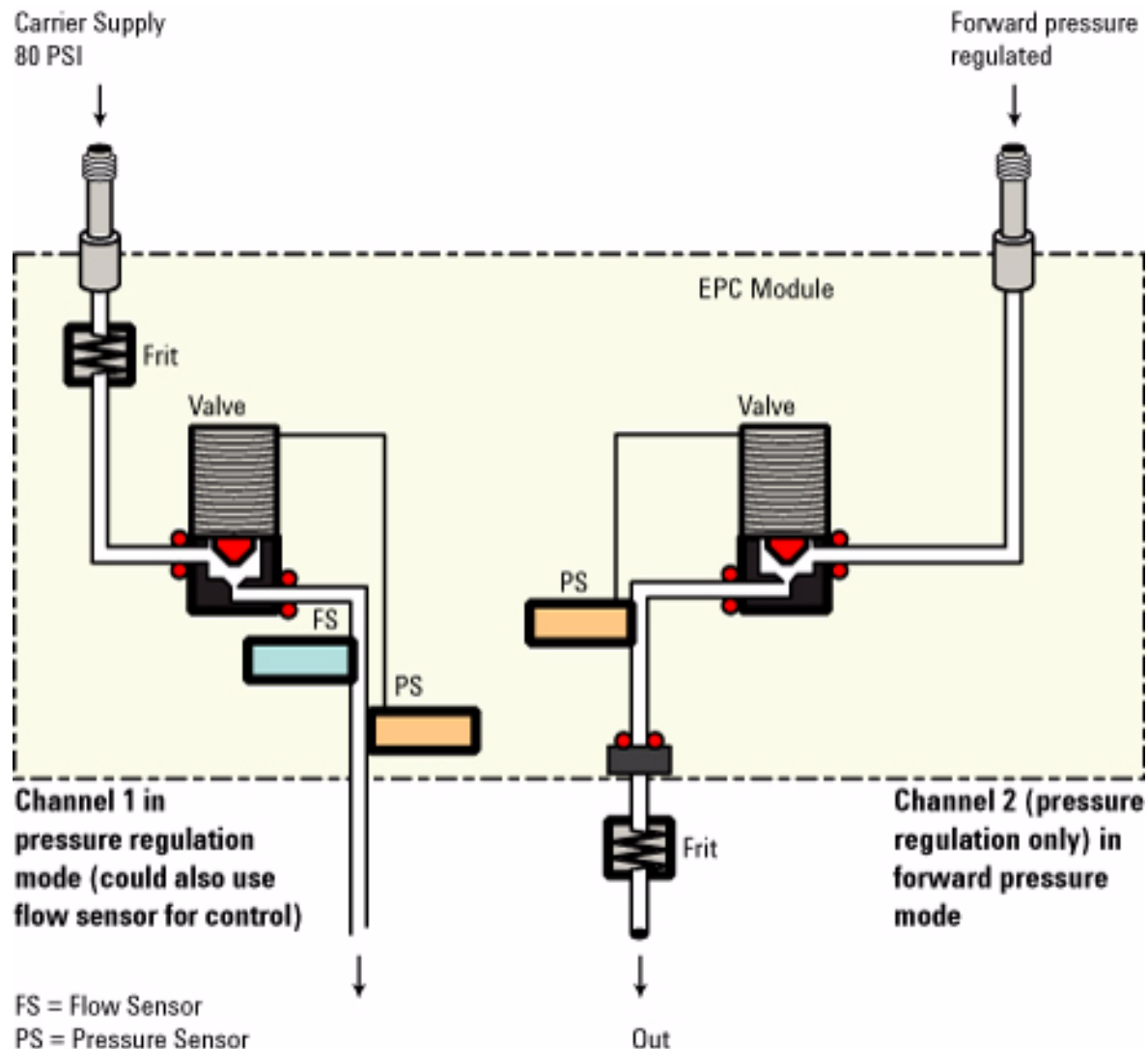

Channel 2 may be used either as a forward- pressure regulator or as a back- pressure regulator, simply by reversing the input and output connections. The back pressure mode can be very useful with a gas sampling valve, where it ensures that the sample pressure in the loop remains constant.

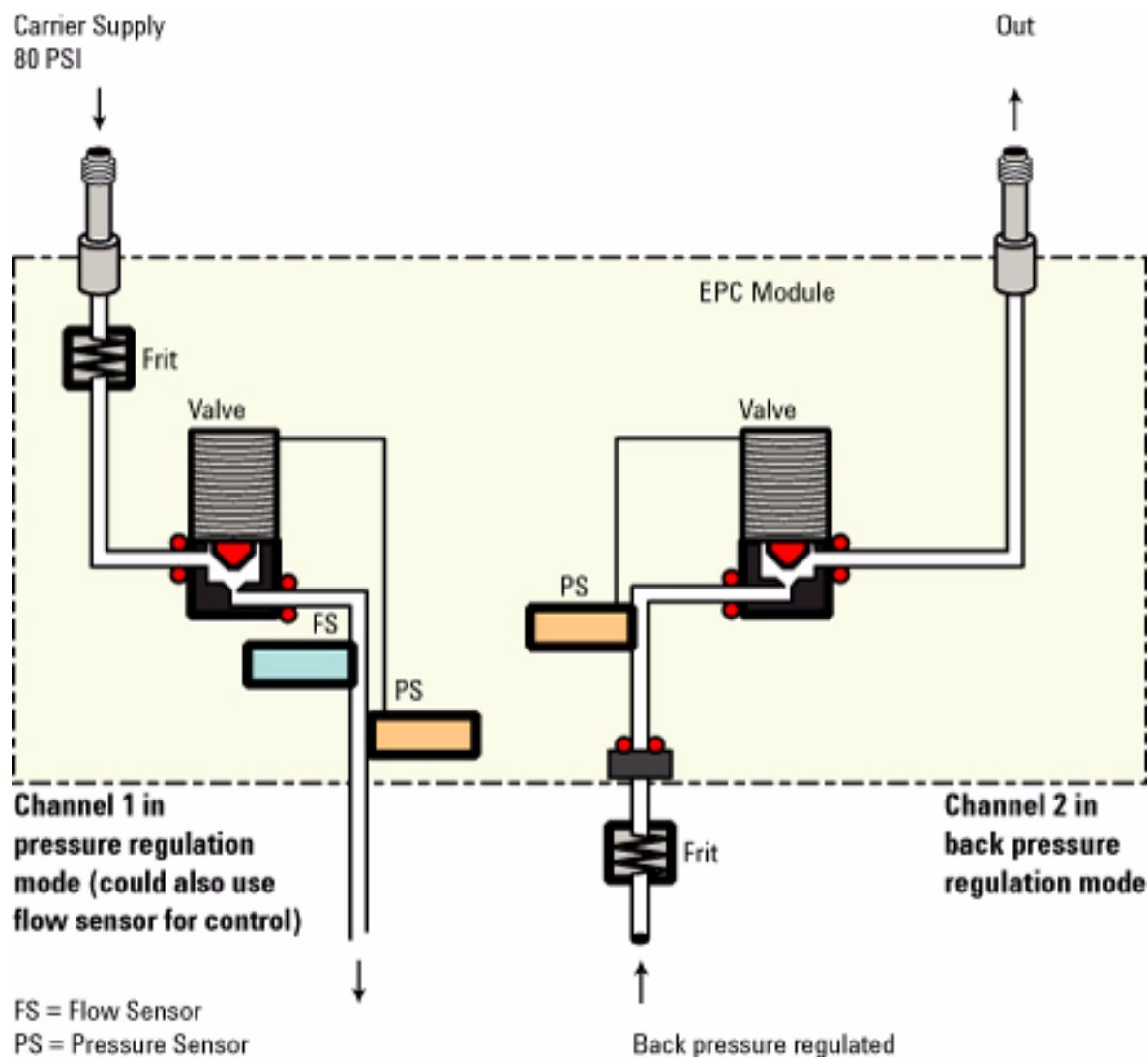

For channel 1, gas input is via a threaded fitting. Gas output is via a coil of metal tubing with a Swagelok fitting on the end.

For channel 2, the connections are the same as for channel 1 if channel 2 is to be used as a forward- pressure regulator. They are reversed—extra fittings/adapters will be needed—if it is to be used as a back- pressure regulator.

PCMs can be installed in several locations:

- In slot 1. The name is **PCM A**.
- In slot 2. The name is **PCM B**.
- In slot 5. If there are no PCMs in slots 1 and 2, the name is **PCM A**. If another PCM is installed in either slot 1 or 2, the PCM in slot 5 takes the name that is not being used (**A** or **B**). If PCMs are installed in both slots 1 and 2, the name is **PCM C**.

- In slot 6. The name is always **PCM C**.

PCM A or B	Slot 3	PCM A	Split vent trap and valve
PCM C	Slot 4	PCM B	

Back of GC

Both channels of a PCM are controlled by the same parameter list. The first two lines refer to channel 1, the remaining lines refer to channel 2.

Auxiliary Pressure Controllers

The Auxiliary Pressure Controller (Aux epc) is also a general purpose device. It has three independent forward- pressure regulated channels. Channels are designated by numbers 1 through 9 (there can be up to 3 Aux eps), depending on where the module is installed.

If an auxiliary channel is specified as the **Inlet** during column configuration, that channel allows run time programming and three- ramp flow or pressure programming.

Gas input is via threaded fittings. Gas output is via coils of metal tubing with Swagelok fittings on the ends.

As you look at the module from the back of the GC, the channels are numbered from left to right according to this scheme:

- In slot 6. The name is **Aux epc #**, where # is 1, 2, or 3 and identifies the channel.
- In slot 5. The name is **Aux epc #**, where # is 4, 5, or 6 and identifies the channel.
- In slot 4. The name is **Aux epc #**, where # is 7, 8, or 9 and identifies the channel.
- In the third detector side of the GC. The name is **Aux epc #**, where # is 7, 8, or 9 and identifies the channel.

Aux epc 4, 5, 6	Slot 3	Slot 1	Split vent trap and valve
Aux epc 1, 2, 3	Aux epc 7, 8, 9	Slot 2	

Back of GC

Restrictors

Both PCMs and auxiliary channels are controlled by pressure setpoints. To work properly, there must be adequate flow resistance downstream of the pressure sensor. Each channel provides a frit-type restrictor. Four frits are available.

Table 24 Auxiliary channel frits

Frit marking	Flow resistance	Flow characteristic	Often used with
Three blue rings	High	3.33 ± 0.3 SCCM @ 15 PSIG	FID Air, QuickSwap, Splitter, Deans Switch
Two red rings	Medium	30 ± 1.5 SCCM H ₂ @ 15 PSIG	FID Hydrogen
One brown ring	Low	400 ± 30 SCCM AIR @ 40 PSIG	NPD Hydrogen
None (brass tube)	Zero	No restriction	Headspace vial pressurization

The brown ring frit is in all channels in the AUX epc when the instrument is shipped. No frit ships in the PCM Aux channel.

When installing or replacing a frit, always use a new O-ring (5180-4181, 12/pk).

Selecting a frit

The frits change the control range of the channels. The objective is to find a frit that allows the required range of flows at reasonable source pressures.

- For an auxiliary channel ordered as an option (part of the GC order), use the frit supplied by the factory.
- For an auxiliary channel ordered as an accessory (separate from the GC order), see the instruction information supplied with the accessory.
- For a non-Agilent instrument, you must experiment to find the appropriate frit.

When you change a frit, you change the physical characteristics of the channel. It may be desirable (or necessary) to change the PID constants for that channel. See “PIDs” on page 155.

Examples

1. Using an Aux epc channel to supply purge gas to a splitter

An Aux epc channel operates only in the forward-pressure mode; it provides a constant pressure at its outlet. It is used to provide gas to some other device, such as a splitter with a makeup gas input.

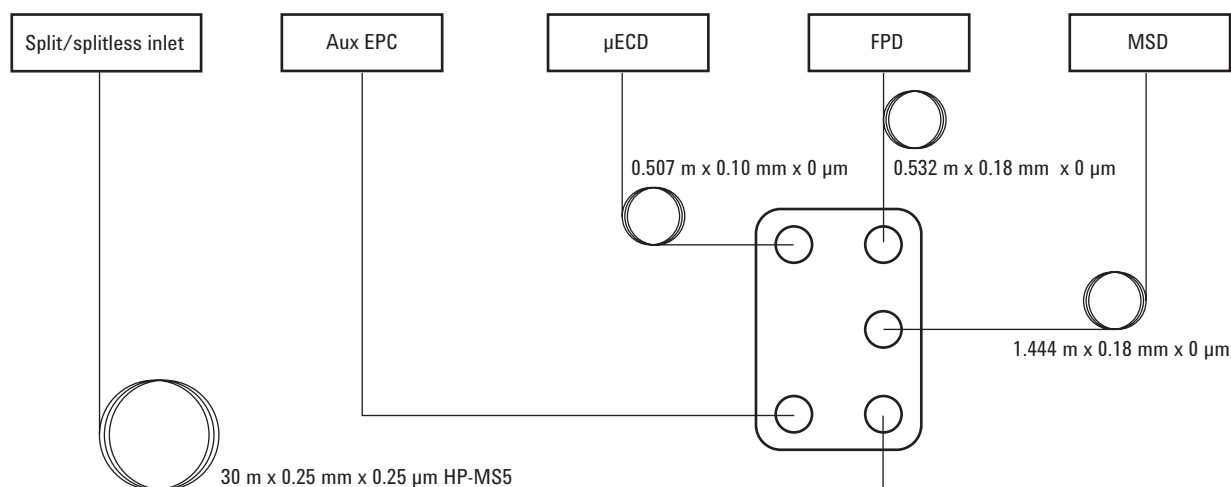

In this configuration, the gas eluting from the column is divided among three detectors. Because the resulting flows can be quite small, makeup gas is added at the splitter. An Aux epc channel provides it.

Assume that we are using channel **Aux epc 1** as the makeup source. The gas is plumbed to the leftmost (as seen from the back of the GC) fitting on the proper module. The outlet tubing for this channel goes to the splitter inside the oven—an extension tube may be needed to reach this far.

The medium frit is probably appropriate for this application.

Rather than have the makeup gas flowing all the time, consider turning it on and off with run time commands.

2. Using the PCM channels

The two channels in a PCM are different. Channel 1 is used to *supply* a pressure. Channel 2 may be used in the same way, but can also be used to *maintain* a pressure by reversing the input and output connections.

Channel 1: Forward-pressure only

This is identical to the carrier gas channel for the packed column inlet.

Channel 2: Two-way channel

If gas is supplied at the threaded connection and delivered by the tubing, this operates the same as channel 1. But the connections can be reversed—requiring some fittings—so that it will maintain the gas supplied to it at a fixed pressure. In this mode it behaves as a controlled leak.

This can be used to maintain the gas in a gas sampling valve at a fixed pressure, even if the supply varies somewhat. The result is improved reproducibility in sample amount.

The figure shows the connections with the valve in the Load position.

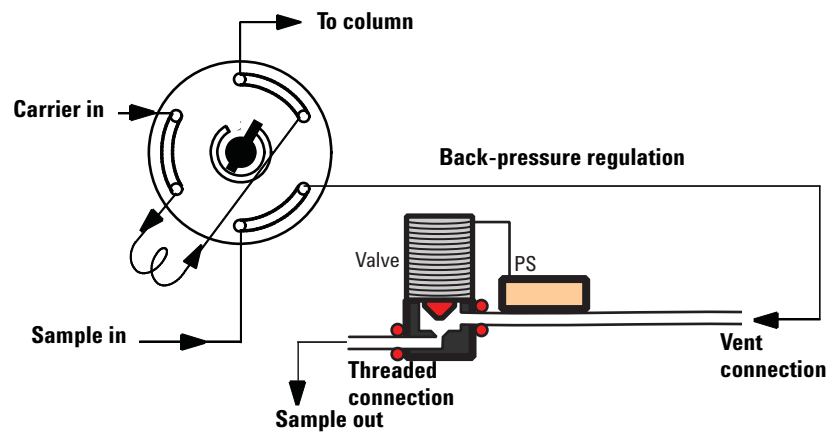



8 Inlets

- Using Hydrogen [167](#)
- Inlet Overview [168](#)
- Carrier Gas Flow Rates [169](#)
- About Gas Saver [170](#)
- Pre Run and Prep Run [171](#)
 - Auto Prep Run [172](#)
- About Heaters [173](#)
- About the Split/Splitless Inlet [175](#)
 - Split/Splitless inlet split mode overview [176](#)
 - Split/Splitless inlet splitless mode overview [177](#)
 - The S/SL inlet pulsed split and splitless modes [178](#)
 - Split/Splitless inlet split mode minimum operating pressures [179](#)
 - Selecting the correct S/SL inlet liner [180](#)
 - Vapor Volume Calculator [182](#)
 - Selecting parameters for the S/SL splitless mode [183](#)
- About the Multimode Inlet [186](#)
 - Septum tightening (MMI) [186](#)
 - Heating the MMI [187](#)
 - Cooling the MMI [187](#)
 - MMI split mode minimum operating pressures [188](#)
 - Selecting the correct MMI liner [189](#)
 - Vapor Volume Calculator [191](#)
 - MMI split and pulsed split modes [191](#)
 - MMI splitless and pulsed splitless modes [194](#)
 - MMI solvent vent mode [201](#)
 - MMI Direct Mode [209](#)
 - To develop a MMI method that uses large volume injection [210](#)
 - Multiple injections with the MMI [213](#)
- About the Cool On-Column Inlet [222](#)
 - Retention gaps [223](#)
 - COC inlet temperature control [223](#)
 - Setting COC inlet flows/pressures [224](#)
- About the PTV Inlet [226](#)
 - PTV sampling heads [226](#)
 - Heating the PTV inlet [227](#)



- Cooling the PTV inlet [228](#)
- PTV inlet split and pulsed split modes [228](#)
- PTV inlet splitless and pulsed splitless modes [232](#)
- PTV inlet solvent vent mode [239](#)
- To develop a PTV method that uses large volume injection [247](#)
- Multiple injections with the PTV inlet [250](#)
- About the Volatiles Interface [255](#)
 - About the VI split mode [257](#)
 - About the VI splitless mode [261](#)
 - About the VI direct mode [266](#)
 - Preparing the Interface for Direct Sample Introduction [269](#)
 - Setting parameters for the VI direct mode [272](#)

Using Hydrogen

WARNING

When using hydrogen (H_2), as the carrier gas, be aware that hydrogen (H_2) gas can flow into the oven and create an explosion hazard. Therefore, be sure that the supply is off until all connections are made, and ensure that the inlet and detector column fittings are either connected to a column or capped at all times when hydrogen (H_2) gas is supplied to the instrument.

WARNING

Hydrogen (H_2) is flammable. Leaks, when confined in an enclosed space, may create a fire or explosion hazard. In any application using hydrogen (H_2), leak test all connections, lines, and valves before operating the instrument. Always turn off the hydrogen (H_2) supply at its source before working on the instrument.

Inlet Overview

Table 25 Comparing inlets

Inlet	Column	Mode	Sample concentration	Comments	Sample to column
Split/splitless	Capillary	Split	High	Useful with large injections	Very little
		Pulsed split	High		Very little
		Splitless	Low	Useful with large injections	All
		Pulsed splitless	Low		All
Multimode	Capillary	Split	High	Multiple injections concentrate analytes and vent solvent	Very little
		Pulsed split	High		Very little
		Splitless	Low		All
		Pulsed splitless	Low		All
		Solvent vent	Low		Most
		Direct			All
Cool on-column	Capillary	n/a	Low or labile	Minimal discrimination and decomposition	All
Packed column	Packed	n/a	Any	OK if resolution not critical	All
	Large capillary	n/a	Any		All
Programmed temperature vaporization	Capillary	Split	High	Multiple injections concentrate analytes and vent solvent	Very little
		Pulsed split	High		Very little
		Splitless	Low		All
		Pulsed splitless	Low		All
		Solvent vent	Low		Most
Volatiles interface (for use with external volatiles sampler)	Capillary	Direct	Low	Lowest dead volume Max flow = 100 mL/min	All
		Split	High		Very little
		Splitless	Low		All

Carrier Gas Flow Rates

The flow rates in [Table 26](#) are recommended for all column temperatures.

Table 26 Column size and carrier flow rate

Column type	Column size	Carrier flow rate, mL/min		
		Hydrogen	Helium	Nitrogen
Packed	1/8-inch		30	20
	1/4-inch		60	40
Capillary	0.05 mm id	0.5	0.4	n/a
	0.10 mm id	1.0	0.8	n/a
	0.20 mm id	2.0	1.6	0.25
	0.25 mm id	2.5	2.0	0.5
	0.32 mm id	3.2	2.6	0.75
	0.53 mm id	5.3	4.2	1.5

About Gas Saver

Gas saver reduces carrier flow from the split vent after the sample is on the column. It applies to the Split/Splitless and PTV inlets (all modes) and to the split and splitless modes of the Volatiles Interface. It is most useful in split applications.

Column head pressure and flow rate are maintained, while purge and split vent flows decrease. Flows—except column flow—remain at the reduced level until you press **[Prep Run]**.

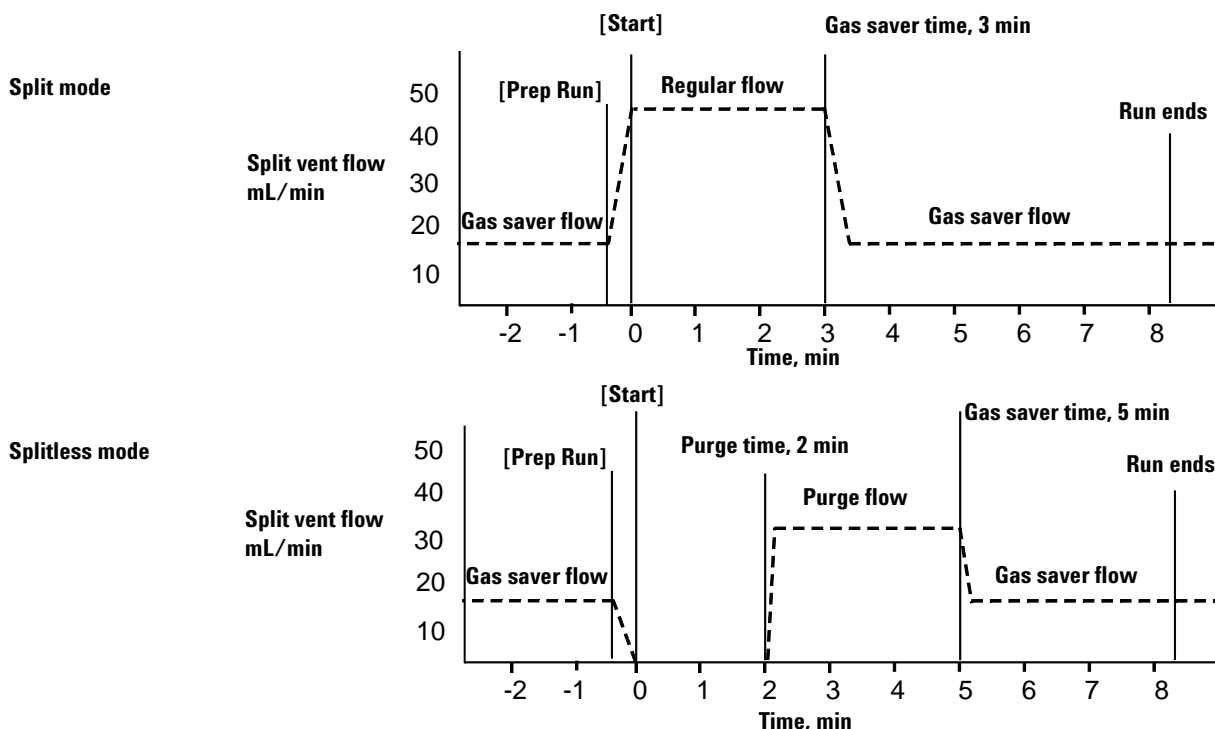

The pulsed modes of the split/splitless and PTV inlets are similar except for the pressure pulse starting at **[Prep Run]** and ending at **Pulse time**. The solvent vent mode of the PTV is more complex; see [“PTV inlet solvent vent mode”](#) on page 239.

To use gas saver

- 1 Press **[Front Inlet]** or **[Back Inlet]**.
- 2 Turn gas saver **On**.
- 3 Set **Gas saver flow**. It must be at least 15 mL/min greater than the column flow.
- 4 If in split mode, set **Saver time** after injection time. In all other modes, set after **Purge time**.

Pre Run and Prep Run

With some inlets and operating modes, certain instrument setpoints are different between runs than during an analysis. To restore the setpoints for injection, you must place the GC into the Pre Run state.

You must use the Pre Run state when:

- Using gas saver with any inlet.
- Using splitless mode with any inlet.
- Using a pressure pulse mode with any inlet.
- Using the solvent vent mode of the PTV inlet.
- Using the direct or splitless mode of the Volatiles Interface.

There are three ways to begin Pre Run—manually (press **[Prep Run]** before each run), automatically (for Agilent samplers), or using **Auto Prep Run** (for non-Agilent samplers). The three methods are discussed below.

During the Pre Run state:

- The Pre Run light blinks and Not Ready is on.
- Setpoints change to the correct values for injection.
- Inlet, detector, and oven equilibration times begin.

When all equilibration times expire, the Pre Run light is on steadily. When all criteria for a run are met, the Not Ready light turns off. The GC is now ready for sample injection.

The **[Prep Run]** key

Press **[Prep Run]** before you inject a sample manually. The GC enters the Pre Run state. When the Pre Run light is steady and the Not Ready light goes off, begin the analysis.

Agilent samplers

If you are using an Agilent automatic sampling system, the **[Prep Run]** function is automatic.

Start the sampler. It generates the **[Prep Run]** function. When all the setpoints are reached and the GC becomes Ready, sample injection begins.

Non-Agilent samplers

With most automatic injection systems, you do not need to use the **[Prep Run]** key. If your sampler or automation controller (for example, an integrator or workstation) does not support the **[Prep Run]** function, you must set the GC to **Auto Prep Run**.

Auto Prep Run

To set this parameter, usually for a non-Agilent integrator, workstation, or other controlling device:

- 1 Press **[Config]** to view a list of configurable parameters.
- 2 Scroll to **Instrument** and press **[Enter]**.
- 3 Scroll to **Auto prep run** and press **[On/Yes]**.

About Heaters

Inlets (and detectors, valve boxes, etc.) are heated. There are six heater connectors on the GC mainframe, located as shown here:

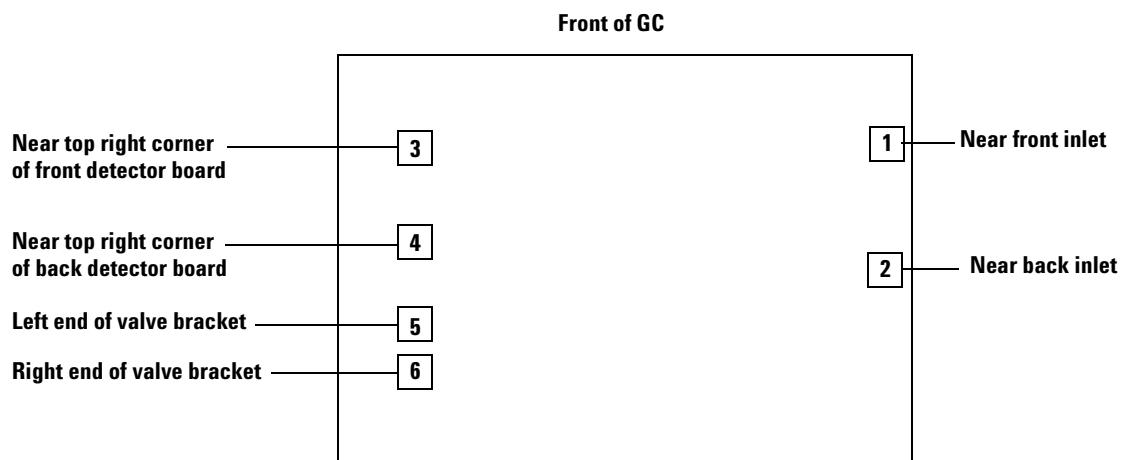

All heater connectors are square, 4-conductor receptacles mounted on brackets.

The next table describes the heaters that are available for each module.

Table 27 Heater connectors by module

Module	Available heater connectors
Front inlet	1 or None
Back inlet	2 or None
Front detector	3 or 5
Back detector	4 or 6
Aux detector 1	5 or 6 or 2
Aux detector 2	None
PCM A	5 or 6 or 1 or 2
PCM B	5 or 6 or 1 or 2
PCM C	5 or 6 or 1 or 2
AUX 1,2,3	None
AUX 4,5,6	None
AUX 7,8,9	None
Valve box	5 or 6 or Both

Table 27 Heater connectors by module (continued)

Module	Available heater connectors
Aux heater 1	5
Aux heater 2	6

Front FPD uses heater connectors 3 and 5.

Back FPD uses heater connectors 4 and 6.

FPDs can be configured for one or two heater versions.

About the Split/Splitless Inlet

This inlet is used for split, splitless, pulsed splitless, or pulsed split analyses. You can choose the operating mode from the inlet parameter list. The *split mode* is generally used for major component analyses, while the *splitless mode* is used for trace analyses. The *pulsed splitless* and *pulsed split modes* are used for the same type of analyses as split or splitless, but allow you to inject larger samples.

Septum tightening (S/SL)

Septum retainer nuts must be tightened enough to obtain a good gas seal, but not so much as to compress the septum and make it difficult to push a syringe needle through it.

For the standard septum retainer nut, an internal spring in the septum retainer applies pressure to the septum. For inlet pressures up to 100 psi, tighten the retainer until the C-ring lifts about 1 mm above the top surface. This is adequate for most situations.

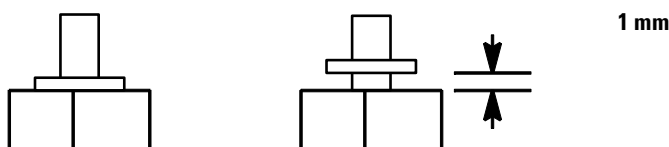

With higher inlet pressures, tighten the septum retainer until the C-ring stops turning, indicating that the retainer is in firm contact with the septum.

If using a Merlin Microseal™ septum, finger tighten the septum nut, until snug (not loose). The pressure capacity depends on the duckbill seal used.

Standard and high-pressure versions of the S/SL inlet

The standard split/splitless inlet is rated to 100 psi pressure at the inlet. It is appropriate for most columns. The high-pressure inlet is rated to 150 psi pressure—it is useful with very small diameter capillary columns that offer considerable resistance to gas flow.

Recommended source pressures are 120 psi and 170 psi respectively.

To determine the version that you have, press **[Front Inlet]** or **[Back Inlet]**, scroll to the **Pressure** line, and press the **[Info]** key. The display will show the pressure range for the inlet—either **1 to 100 psi** (for the standard version) or **1 to 150 psi** (for the high- pressure version).

Split/Splitless inlet split mode overview

During a split injection, a liquid sample is introduced into a hot inlet where it vaporizes rapidly. A small amount of the vapor enters the column while the major portion exits from the split/purge vent. The ratio of column flow to split vent flow is controlled by the user. Split injections are primarily used for high concentration samples when you can afford to lose most of the sample out the split/purge vent. It is also used for samples that cannot be diluted.

The **split ratio** is equal to the split vent flow divided by the column flow. If the column has been configured, the desired split ratio can be entered directly.

The pneumatics for this inlet in split mode operation are shown in the figure below.

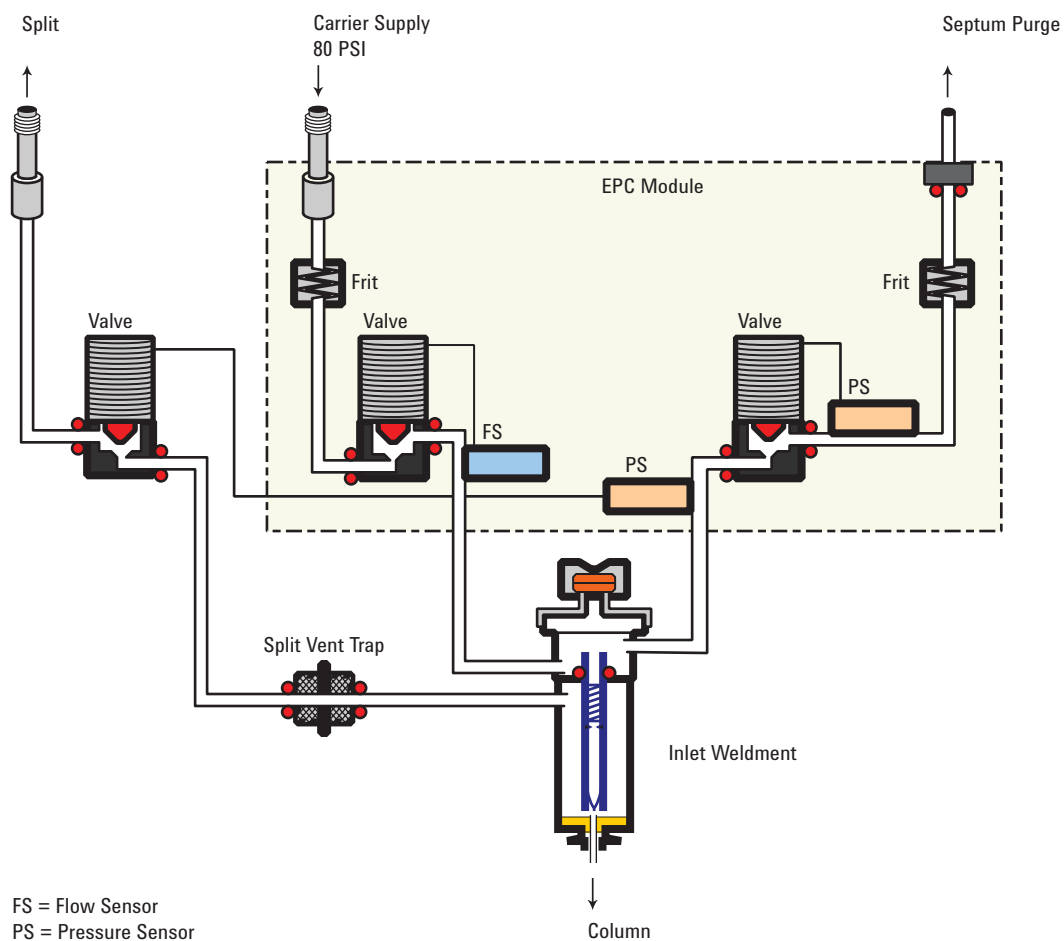

Split/Splitless inlet splitless mode overview

In this mode, the split vent valve is closed during the injection and remains so while the sample is vaporized in the liner and transferred to the column. At a specified time after injection, the valve opens to sweep any vapors remaining in the liner out the split vent. This avoids solvent tailing due to the large inlet volume and small column flow rate. Specify the purge time and purge flow rate in the inlet parameter list.

The septum purge flow may be either on at all times (Standard mode) or on only between the purge time and the end of the run (Switched mode).

If you are using gas saver, the gas saver time should be *after* the purge time.

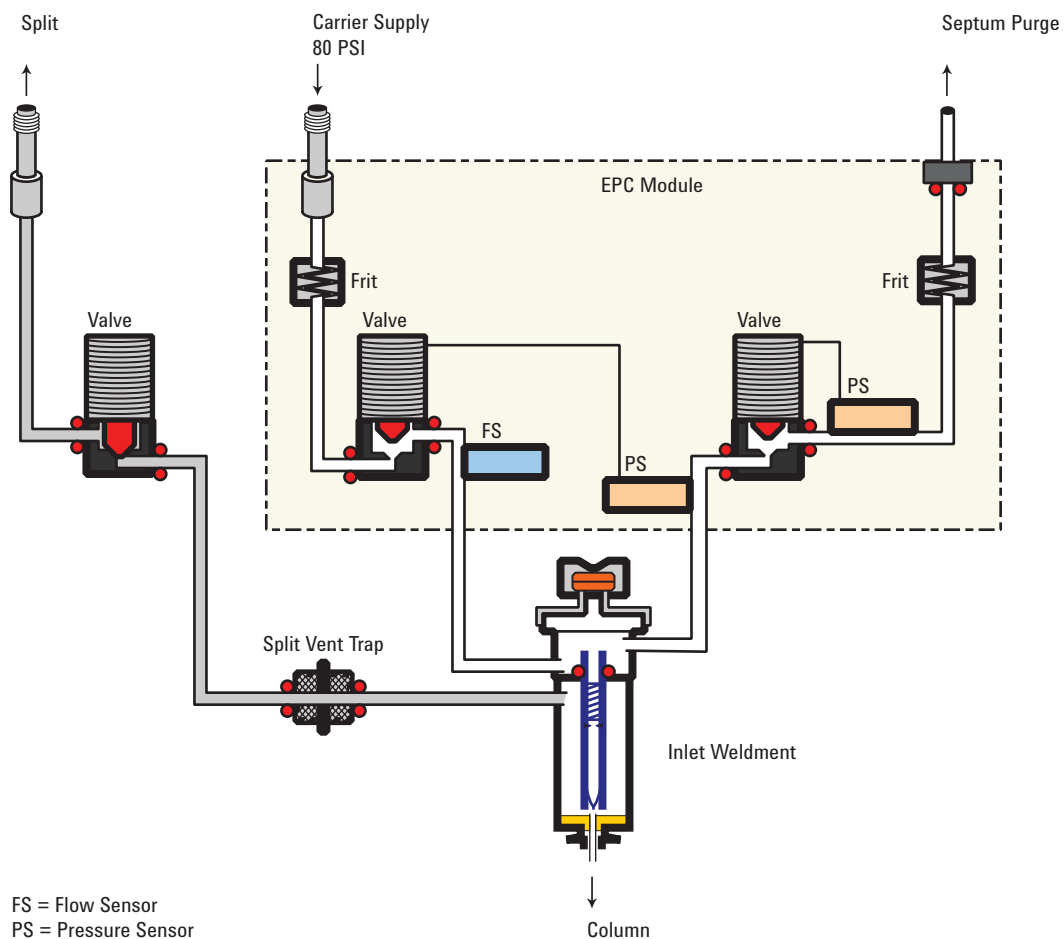

The S/SL inlet pulsed split and splitless modes

The pressure pulse modes increase inlet pressure just before the beginning of a run and return it to the normal value after a specified amount of time. The pressure pulse:

- reduces the solvent vapor volume
- reduces the risk of inlet overload
- tightens the sample band
- may allow use of a 2 mm liner, reducing the active glass area

If your chromatography is degraded by the pressure pulse, a retention gap may help restore peak shape.

You must press [**Prep Run**] before doing manual injections in the pressure pulse modes. See “[Pre Run and Prep Run](#)” on page 171 for details.

You can do column pressure and flow programming when in the pressure pulse mode. However, the pressure pulse will take precedence over the column pressure or flow ramp.

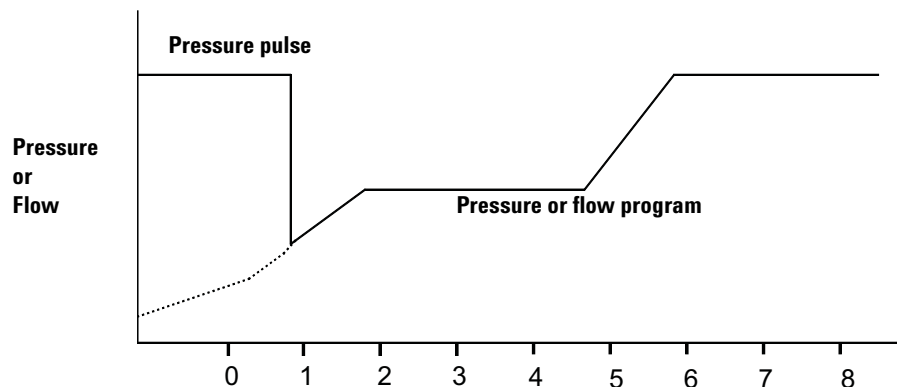

Split/Splitless inlet split mode minimum operating pressures

The minimum recommended inlet total flow is 20 mL/minute. When the split/splitless inlet is operated in Split mode, there will be a minimum pressure at which the inlet can operate. Typically, low inlet pressures may be required for shorter, wide bore columns. The minimum pressure is a function of carrier gas type, total inlet flow, liner design, and possible contamination of the split vent tube or trap.

A wide bore column requires a much lower inlet pressure than a typical capillary column to maintain a given flow. Setting the split ratio (total flow) too high when using a wide bore column can create an unstable control relationship between the pressure and flow control loops.

Table 28 Approximate minimum viable inlet pressures for split/splitless inlet in split mode, in psi (kPa)

	Split vent flow (mL/min)			
	50–100	100–200	200–400	400–600
Helium and hydrogen carrier gases				
Split liners - 5183-4647, 19251-60540	2.5 (17.2)	3.5 (24.1)	4.5 (31)	6.0 (41.4)
Splitless liners - 5062-3587, 5181-8818	4.0 (27.6)	5.5 (37.9)	8.0 (55.2)	11.0 (75.4)
Nitrogen carrier gas				
Split liners - 19251-60540, 5183-4647	3.0 (20.7)	4.0(27.6)	—	—
Splitless liners - 5062-3587, 5181-8818	4.0 (27.6)	6.0 (41.4)	—	—





These numbers are based on the resistance to flow of new, clean inlet systems. Sample condensation in the split vent tube or a dirty filter can make these values non-attainable.

Selecting the correct S/SL inlet liner

Split liner

A good liner for split mode operation will offer very little restriction to the split flow path between the bottom of the liner and the inlet gold seal and between the outside of the liner and the inside of the injection port body. The preferred Agilent split liner, part number 5183-4647, incorporates a glass positioning bead on the bottom to facilitate this. It will also incorporate glass wool or some other source of surface area inside the liner that provides for complete sample vaporization across the boiling point range of the sample. Select an appropriate liner from [Table 29](#).

Table 29 Split mode liners

Liner	Description	Volume	Mode	Deactivated	Part Number
	Low Pressure Drop – Positioning Bead	870 µL	Split – Fast Injection	Yes	5183-4647
	4mm ID, Glass Wool	990 µL	Split – Fast Injection	No	19251-60540
	Empty Pin & Cup	800 µL	Split – Manual Only	No	18740-80190
	Packed Pin & Cup	800 µL	Split – Manual Only	No	18740-60840

Splitless liner

The liner volume must contain the solvent vapor. The liner should be deactivated to minimize sample breakdown during the purge delay. Solvent vapor volume can be reduced by using Pulsed Splitless mode. Use the “[Vapor Volume Calculator](#)” to determine vapor volume requirements.

Vapor volume < 300 µL Use 2 mm liner (250 µL volume), 5181- 8818 or similar.











Vapor volume 225 – 300 µL Consider pulsed splitless mode to reduce vapor volume.

Vapor volume > 300 µL Use 4 mm liner, 5062- 3587 or similar.

Vapor volume > 800 µL Consider pulsed splitless mode to reduce vapor volume.

For thermally labile or reactive samples, use G1544- 80700 (open top) or G1544- 80730 (top taper) liners.

Table 30 Splitless mode liners

Liner	Description	Volume	Mode	Deactivated	Part Number
	Single Taper Glass Wool	900 uL	Splitless	Yes	5062-3587
	Single Taper	900 uL	Splitless	Yes	5181-3316
	Dual Taper	800 uL	Splitless	Yes	5181-3315
	2 mm Quartz	250 uL	Splitless	No	18740-80220
	2 mm Quartz	250 uL	Splitless	Yes	5181-8818
	1.5 mm	140 uL	Direct Inject, Purge and Trap, Headspace	No	18740-80200
	Single Taper Glass Wool	900 uL	Splitless	Yes	5062-3587
	Single Taper	900 uL	Splitless	Yes	5181-3316
	4 mm Single Taper	Direct column connect		Yes	G1544-80730
	4 mm Dual Taper	Direct column connect		Yes	G1544-80700

Vapor Volume Calculator

Agilent provides a Vapor Volume Calculator to help you determine if a liner is suitable for a method. To use the calculator install the Agilent Instrument utility provided with the GC. The calculator is also provided with the Agilent G4600AA Lab Advisor software.

Setting parameters for the S/SL split mode

Mode The current operating mode—split

Temperature Actual and setpoint inlet temperatures

Pressure Actual and setpoint inlet pressure

Split ratio The ratio of split vent flow to column flow. Column flow is set at the Column parameter list. This line appears only if your columns in the flow path are defined.

Split flow Flow, in mL/min, from the split vent. This line appears only if your columns in the flow path are defined.

Total flow This is the total flow into the inlet, which is the sum of the split vent flow, column flow, and septum purge flow. When you change the total flow, the split ratio and split vent flow change while the column flow and pressure remain the same.

Septum Purge Flow, in mL/min, through the septum purge line. Recommended range is 1 to 5 mL/min.

If all columns in the flow path are defined

- 1 Press [**Front Inlet**] or [**Back Inlet**].
- 2 Scroll to **Mode:** and press [**Mode/Type**]. Select **Split**.
- 3 Set the inlet temperature.
- 4 If you want a specific split ratio, scroll to **Split ratio** and enter that number. **Split flow** will be calculated for you.
- 5 If you want a specific split flow, scroll to **Split flow** and enter that number. **Split ratio** will be calculated for you.
- 6 If desired, turn on **Gas saver**. Set **Saver time** after the injection time. Press [**Prep Run**] (see “[Pre Run and Prep Run](#)” on page 171) before manually injecting the sample.

If a column in the flow path is not defined

- 1 Press **[Front Inlet]** or **[Back Inlet]**.
- 2 Set the inlet temperature.
- 3 Set **Total flow** into the inlet. It must exceed your intended **Septum Purge** flow. Measure the split vent flow using a flow meter.
- 4 Subtract split vent flow and septum purge flow (see “[Pre Run and Prep Run](#)” on page 171) from **Total flow** to get column flow.
- 5 Calculate the split ratio (split vent flow/column flow). Adjust as needed.

Selecting parameters for the S/SL splitless mode

A successful splitless injection consists of these steps:

- 1 Vaporize the sample and solvent in a heated inlet.
- 2 Use a low flow and low oven temperature to create a solvent-saturated zone at the head of the column.
- 3 Use this zone to trap and reconcentrate the sample at the head of the column.
- 4 Wait until all, or at least most, of the sample has transferred to the column. Then discard the remaining vapor in the inlet—which is mostly solvent—by opening a purge valve. This eliminates the long solvent tail that this vapor would otherwise cause.
- 5 Raise the oven temperature to release the solvent and then the sample from the head of the column.

Some experimentation is needed to refine the operating conditions. [Table 31](#) provides starting values for the critical parameters.

Table 31 Splitless mode inlet parameters

Parameter	Allowed setpoint range	Suggested starting value
Oven temperature	No cryo, 24 °C to 450 °C CO ₂ cryo, –60 °C to 450 °C N ₂ cryo, –80 °C to 450 °C	10 °C below solvent boiling point
Oven initial time	0 to 999.9 minutes	≥ Inlet purge time
Inlet purge time	0 to 999.9 minutes	$\frac{2 \times \text{Liner volume}}{\text{Column flow}}$

Table 31 Splitless mode inlet parameters

Parameter	Allowed setpoint range	Suggested starting value
Gas saver time	0 to 999.9 minutes	After purge time
Gas saver flow	15 to 1000 mL/min	15 mL/min greater than maximum column flow

Setting parameters for the S/SL splitless mode

Mode The current operating mode—splitless

Oven temperature Below solvent boiling point

Temperature Actual and setpoint inlet temperatures

Pressure Actual and setpoint inlet pressure in psi, bar, or kPa

Purge time The time, after the beginning of the run, when you want the purge valve to open. This is the time in which the vaporized sample transfers from the liner to the column.

Purge flow The flow, in mL/min, from the purge vent, at **Purge time**. You will not be able to specify this value if any column in the flow path is not defined.

Total flow The actual flow to the inlet during a Pre-run (Pre-run light is on and not blinking) and during a run before purge time. You cannot enter a setpoint at these times. At all other times, **Total flow** will have both setpoint and actual values.

Septum Purge Flow, in mL/min, through the septum purge line.

Septum Purge Flow Mode Standard (septum purge flow is On at all times) or Switched (septum purge flow is Off during injection, turns On at Purge time).

If all columns in the flow path are defined

- 1 Press **[Front Inlet]** or **[Back Inlet]**.
- 2 Scroll to **Mode:** and press **[Mode/Type]**. Select **Splitless**.
- 3 Set the inlet temperature.
- 4 Enter a **Purge time** and a **Purge flow**.
- 5 If desired, turn on **Gas saver**. Make certain the time is set after the **Purge time**.

- 6 Press [**Prep Run**] (see “Pre Run and Prep Run” on page 171) before manually injecting a sample (this is automatic for Agilent ALS).

If a column in the flow path is not defined

- 1 Press [**Front Inlet**] or [**Back Inlet**].
- 2 Scroll to **Mode:** and press [**Mode/Type**]. Select **Splitless**.
- 3 Set the inlet temperature.
- 4 Enter a **Purge time**.
- 5 Set your **Total flow** greater than the sum of column flow plus the septum purge flow—see “Pre Run and Prep Run” on page 171—to guarantee adequate column flow.
- 6 Press [**Prep Run**] (see “Pre Run and Prep Run” on page 171) before manually injecting a sample.

Setting parameters for the S/SL pulsed modes

The pulsed mode parameters are the same as the non-pulsed parameters, but with two additional values.

Pulsed pressure The inlet pressure you want at the start of the run. The pressure rises to this value when [**Prep Run**] is pressed and remains constant until **Pulse time** elapses, when it returns to **Pressure**.

Pulse time This is the time after the start of the run when the inlet pressure returns to **Pressure**.

About the Multimode Inlet

The Agilent Multimode (MMI) Inlet System has five operating modes:

- The *split mode* is generally used for major component analyses.
- The *pulsed split mode* is like the split mode, but with a pressure pulse applied to the inlet during sample introduction to speed the transfer of material to the column.
- The *splitless mode* is used for trace analyses.
- The *pulsed splitless mode* allows for a pressure pulse during sample introduction.
- The *solvent vent mode* is used for large volume injection. Either single or multiple injections can be made for each run.
- The *direct mode* allows for a direct forward pressure of carrier gas through the column. Both the split vent valve and the septum purge valve are closed.

The MMI can be used with both manual and automatic injection.

Automatic multiple injections (large volume injections) is not available under GC control alone. See “[MMI solvent vent mode](#)” on page 201.

Septum tightening (MMI)

Septum retainer nuts must be tightened enough to obtain a good gas seal, but not so much as to compress the septum and make it difficult to push a syringe needle through it.

For the standard septum retainer nut, an internal spring in the septum retainer applies pressure to the septum. For inlet pressures up to 100 psi, tighten the retainer until the C- ring lifts about 1 mm above the top surface. This is adequate for most situations.

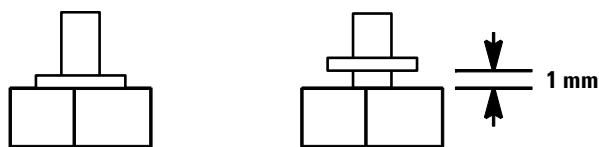

With higher inlet pressures, tighten the septum retainer until the C- ring stops turning, indicating that the retainer is in firm contact with the septum.

If using a Merlin Microseal™ septum, finger tighten the septum nut, until snug (not loose). The pressure capacity depends on the duckbill seal used.

Heating the MMI

Programming the MMI temperature is similar to programming the column oven. Access the inlet parameters by pressing [**Front Inlet**] or [**Back Inlet**]. Temperature can be programmed with an initial temperature and up to 10 ramps (rates and plateaus). See “[MMI split and pulsed split modes](#)” on page 191 for details.

At the end of the run and during post-run, the MMI is held at its final temperature. This permits backflushing without contaminating the inlet.

Additional temperature ramps

For most purposes, the MMI is designed to hold the sample in the inlet liner until the entire sample—there could be several injections—has been injected. Then the MMI is heated rapidly to transfer the sample to the column. This can be accomplished with an initial hold, a single ramp, and a hold at the end to complete sample transfer.

Additional ramps are available and have several possible uses:

- The inlet can be heated to a high temperature to thermally clean the liner for the next run.
- The inlet can be programmed downward—just set the Final temp below the previous temperature—to reduce thermal stress on the inlet.
- Downward programming can be used to prepare the inlet for the next run. This can reduce cycle time for greater sample throughput.

Cooling the MMI

If using cryogen to cool the MMI inlet, both liquid carbon dioxide (LCO₂) and liquid nitrogen (LN₂) are supported. In addition to the cryogenic coolants, the MMI supports compressed air cooling on both the LCO₂ and LN₂ cooling options for legacy applications.

If using cryo as the coolant when configuring the initial inlet setpoint, set the **Use cryo temperature** equal to or higher than the inlet setpoint to cool the inlet and hold the setpoint until the

inlet temperature program exceeds the **Use cryo temperature**. If the **Use cryo temperature** is less than the inlet setpoint, cryogen will cool the inlet to the initial setpoint and turn off.

If using compressed air as the coolant when configuring the initial inlet setpoint, **Use cryo temperature** behaves differently when in **Compressed air** mode than it does when in **N2 cryo** or **CO2 cryo** mode. In **Compressed air** mode, the air coolant is used to cool the inlet regardless of the **Use cryo temperature** setpoint during the cooling cycle. If the inlet reaches setpoint, the air coolant is turned off and stays off. If the oven temperature is high enough or the inlet was very hot previously, it is possible that the inlet temperature will rise and the GC will go not ready. For this reason, it is better to set the instrument cooling configuration as **N2 cryo** or **CO2 cryo** when using compressed air as the coolant. When using compressed air, the LN₂ hardware cools the inlet faster than the LCO₂ hardware. Never use LCO₂ or LN₂ when the instrument is configured in **Compressed air** mode.

If cryo is turned on, and if the inlet is cooled during a run, cryogen is used to achieve the setpoint. This may have a negative impact on the chromatographic performance of the oven and cause distorted peaks.

When a method ends, the cooling setpoint returns to the initial state of the method, unless you load another method. To conserve coolant when the GC is idle, load a method that does not use a cooling configuration.

See [“To configure the MMI coolant”](#) on page 31.

MMI split mode minimum operating pressures

The minimum recommended inlet total flow is 20 mL/minute. When the inlet is operated in a Split mode, there will be a minimum pressure at which the inlet can operate. Typically, low inlet pressures may be required for shorter, wide bore columns. The minimum pressure is a function of carrier gas type, total inlet flow, liner design, and possible contamination of the split vent tube or trap.

A wide bore column requires a much lower inlet pressure than a typical capillary column to maintain a given flow. Setting the split ratio (total flow) too high when using a wide bore column can create an unstable control relationship between the pressure and flow control loops.

Table 32 Approximate minimum viable inlet pressures for MMI in split mode, in psi (kPa)

	Split vent flow (mL/min)			
	50–100	100–200	200–400	400–600
Helium and hydrogen carrier gases				
Split liners - 5183-4647, 19251-60540	2.5 (17.2)	3.5 (24.1)	4.5 (31)	6.0 (41.4)
Splitless liners - 5062-3587, 5181-8818	4.0 (27.6)	5.5 (37.9)	8.0 (55.2)	11.0 (75.4)
Nitrogen carrier gas				
Split liners - 19251-60540, 5183-4647	3.0 (20.7)	4.0(27.6)	—	—
Splitless liners - 5062-3587, 5181-8818	4.0 (27.6)	6.0 (41.4)	—	—





These numbers are based on the resistance to flow of new, clean inlet systems. Sample condensation in the split vent tube or a dirty filter can make these values non-attainable.

Selecting the correct MMI liner

Split liner

A good liner for split mode operation will offer very little restriction to the split flow path between the bottom of the liner and the inlet body and between the outside of the liner and the inside of the inlet body. The preferred Agilent split liner, part number 5183-4647, incorporates a glass positioning bead on the bottom to facilitate this. It will also incorporate glass wool or some other source of surface area inside the liner that provides for complete sample vaporization across the boiling point range of the sample. Select an appropriate liner from [Table 33](#).

Table 33 Split mode liners

Liner	Description	Volume	Mode	Deactivated	Part Number
	Low Pressure Drop – Positioning Bead	870 µL	Split – Fast Injection	Yes	5183-4647
	4mm ID, Glass Wool	990 µL	Split – Fast Injection	No	19251-60540
	Empty Pin & Cup	800 µL	Split – Manual Only	No	18740-80190
	Packed Pin & Cup	800 µL	Split – Manual Only	No	18740-60840

Splitless liner

The liner volume must contain the solvent vapor. The liner should be deactivated to minimize sample breakdown during the purge delay. Solvent vapor volume can be reduced by using Pulsed Splitless mode. Use the [“Vapor Volume Calculator”](#) to determine vapor volume requirements.

Vapor volume < 300 μL Use 2 mm liner (250 μL volume), 5181- 8818 or similar.











Vapor volume 225 – 300 μL Consider pulsed splitless mode to reduce vapor volume.

Vapor volume > 300 μL Use 4 mm liner, 5062- 3587 or similar.

Vapor volume > 800 μL Consider pulsed splitless mode to reduce vapor volume.

For thermally labile or reactive samples, use G1544- 80700 (open top) or G1544- 80730 (top taper) liners.

Table 34 Splitless mode liners

Liner	Description	Volume	Mode	Deactivated	Part Number
	Single Taper Glass Wool	900 μL	Splitless	Yes	5062-3587
	Single Taper	900 μL	Splitless	Yes	5181-3316
	Dual Taper	800 μL	Splitless	Yes	5181-3315
	2 mm Quartz	250 μL	Splitless	No	18740-80220
	2 mm Quartz	250 μL	Splitless	Yes	5181-8818
	1.5 mm	140 μL	Direct Inject, Purge and Trap, Headspace	No	18740-80200
	Single Taper Glass Wool	900 μL	Splitless	Yes	5062-3587
	Single Taper	900 μL	Splitless	Yes	5181-3316
	4 mm Single Taper	Direct column connect		Yes	G1544-80730
	4 mm Dual Taper	Direct column connect		Yes	G1544-80700

Vapor Volume Calculator

Agilent provides a Vapor Volume Calculator to help you determine if a liner is suitable for a method. To use the calculator install the Agilent Instrument utility provided with the GC. The calculator is also provided with the Agilent G4600AA Lab Advisor software.

MMI split and pulsed split modes

The two split modes—with or without a pressure pulse—divide the gas stream entering the inlet between the column flow and the split vent flow through the solenoid valve. The ratio of the split vent flow to the column flow is called the split ratio.

The next figure shows the flows with split and pulsed split modes.

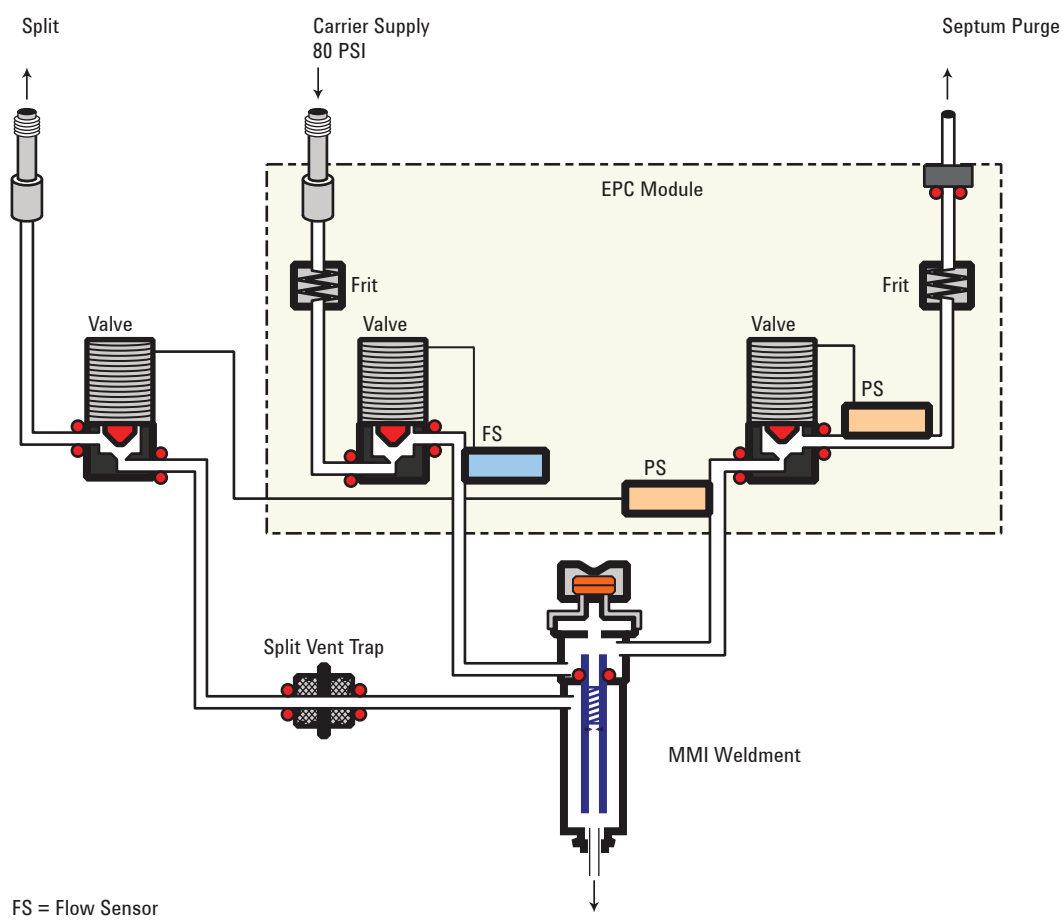

Cold split introduction

For cold split sample introduction, use an initial inlet temperature below the normal boiling point of the solvent. If the liner volume is enough to hold all the vaporized solvent, start the first inlet temperature ramp at 0.1 minutes with a high heating rate (500 °C/min or higher). The final temperature should be high enough to volatilize the heaviest analytes from the liner and should be held for at least 5 minutes. A final temperature of 350 °C for 5 minutes has proven sufficient to quantitatively transfer C₄₄.

For larger injection volumes or to eliminate the solvent, hold the initial temperature long enough to vent the solvent through the split vent and then begin the first ramp. Use a fast rate for thermally stable analytes. Slower rates may help minimize thermal degradation in the inlet.

A single temperature ramp is enough for the injection process. The remaining ramps may be used to clean the liner or to reduce the inlet temperature in preparation for the next injection.

Hot split introduction

For hot split introduction, set an initial temperature high enough to volatilize the analytes. No additional thermal parameters are required as the inlet will maintain the setpoint throughout the run.

Setting parameters for split mode operation

Mode: The current operating mode—split or pulsed split

Temperature Actual and setpoint inlet temperatures.

Initial temperature Starting temperature for the inlet.

Initial time Hold time at the inlet initial temperature.

Rate # Temperature program rates for inlet thermal ramps.

Final temp # Final inlet temperature for ramp 1- 10.

Final time # Hold time at Final temp 1- 10.

Pressure Actual and setpoint inlet pressure. Controls capillary column flow and linear velocity.

Split ratio The ratio of split flow to column flow. Column flow is set in the column parameter list. This line does not appear if a column in the flow path is not defined.

Split flow Flow, in mL/min, from the split/purge vent. This line does not appear if a column in the flow path is not defined.

Total flow These are the actual and setpoint values of the total flow into the inlet, which is the sum of the split flow, column flow, and septum purge flow. When you change the total flow, the split ratio and split flow change while the column flow and pressure remain the same.

Septum Purge Flow through the septum purge vent.

Gas saver On to reduce split vent flow at **Saver time**.

Saver flow Reduced split vent flow, at least 15 mL/min.

Saver time Time when flow is reduced to save gas.

If all columns in the flow path are defined

- 1 Press **[Front Inlet]**.
- 2 Scroll to **Mode:** and press **[Mode/Type]**. Select **Split** or **Pulsed split**.
- 3 Set the inlet temperature (**Initial temperature**) and any desired ramps.
- 4 If you want a specific split ratio, scroll to **Split ratio** and enter that number. The split flow will be calculated and set for you.
- 5 If you want a specific split flow, scroll to **Split flow** and enter that number. The split ratio will be calculated and displayed for you.
- 6 If you selected **Pulsed split**, enter values for **Pulsed pressure** (pressure at injection) and **Pulse time** (minutes after injection to return to normal pressure).
- 7 If desired, turn on **Gas saver**. Set the **Saver time** after the injection time.
- 8 Press **[Prep Run]** before manually injecting the sample if the Gas Saver is on (see “[Pre Run and Prep Run](#)” on page 171 for details.).

If a column in the flow path is not defined

- 1 Press **[Front Inlet]**.
- 2 Set the inlet temperature (**Initial temperature**) and any desired ramps.
- 3 Set other parameters as described for a defined column.
- 4 Set **Total flow** into the inlet. Measure flows out of the split vent and septum purge vent using a flow meter.
- 5 Subtract the septum purge flow and split vent flow from **Total flow** to get column flow.
- 6 Calculate the split ratio (split vent flow/column flow). Adjust as needed

MMI splitless and pulsed splitless modes

In these modes—with or without a pressure pulse—the split vent valve is closed during injection and vaporization of the sample and stays so while the sample transfers to the column.

At a specified time after injection, the valve opens to sweep vapors left in the liner out the split vent. This avoids solvent tailing due to the large inlet volume and small column flow rate.

Stage 1. Sample injection

With the split vent valve closed, the sample and solvent transfer to the column.

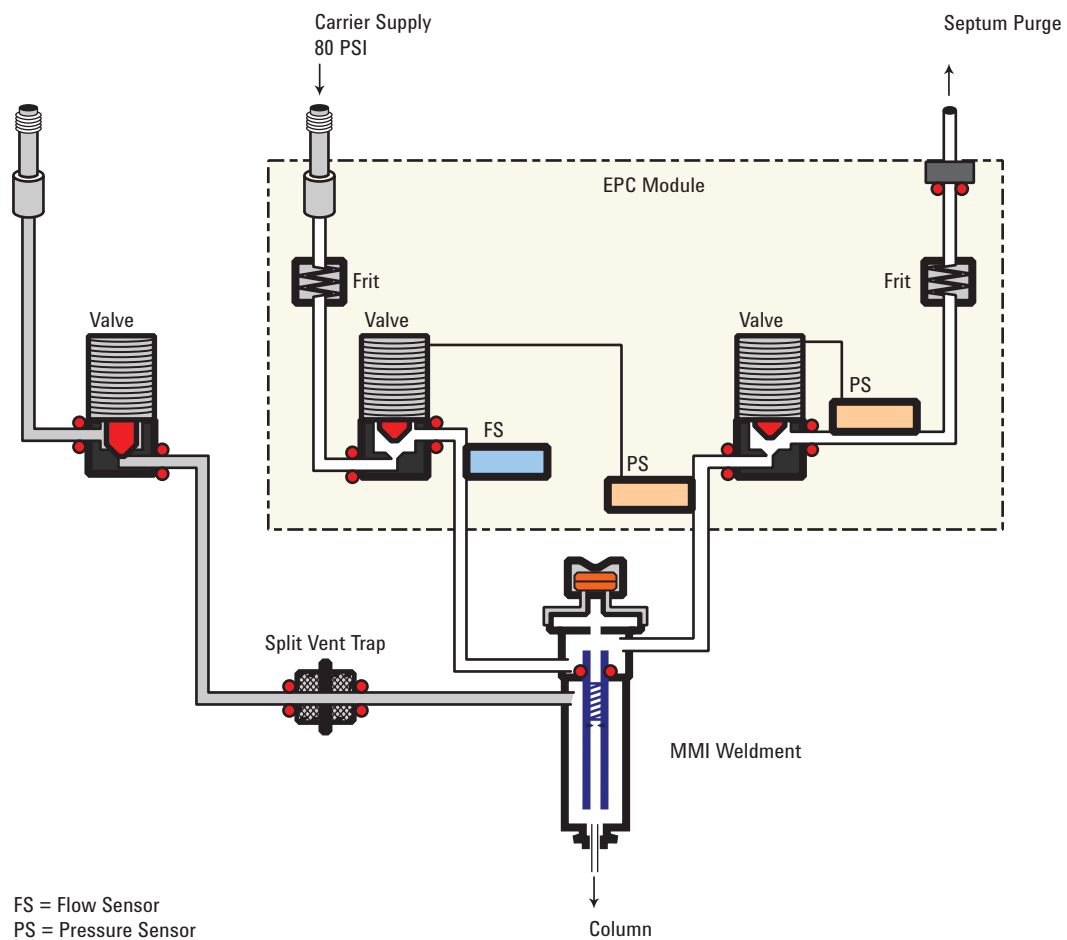

Stage 2. Solvent purging

After the sample has transferred to the column, the split vent valve opens to purge remaining solvent vapor from the inlet.

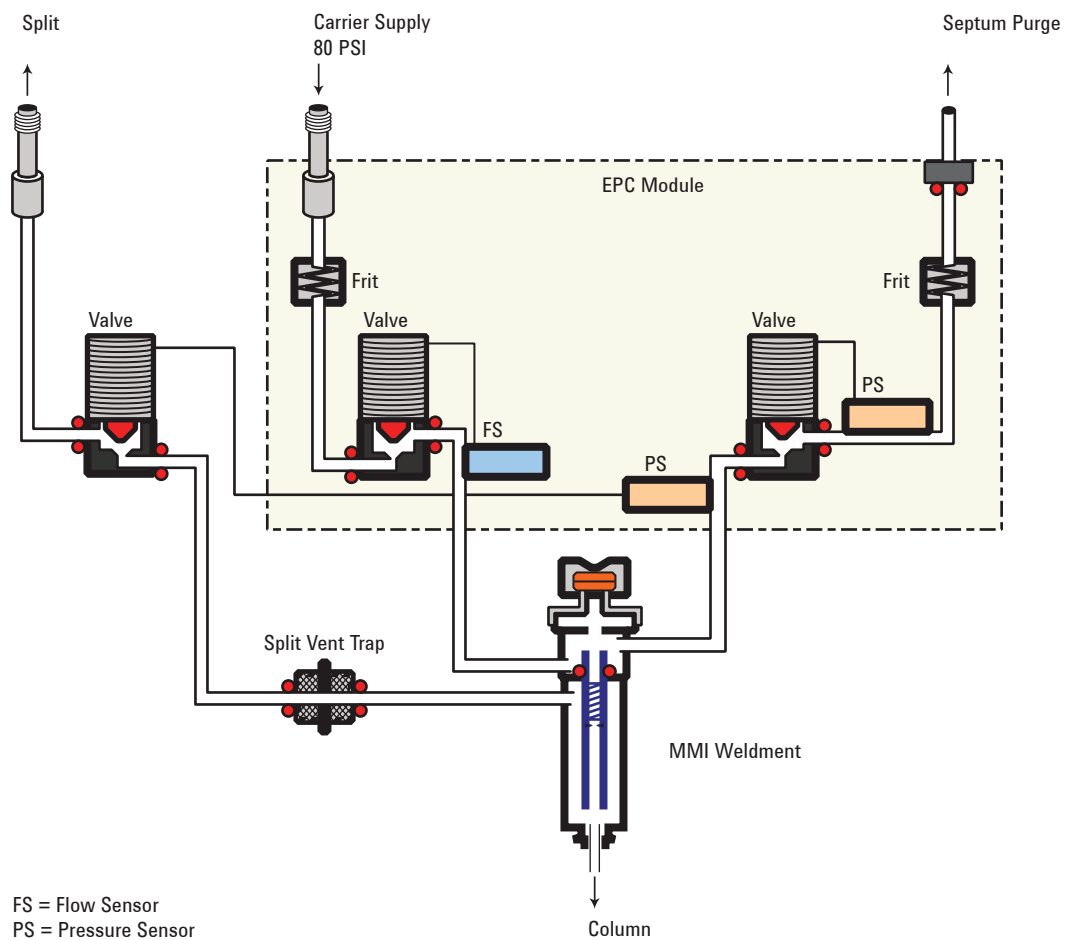

Timelines

This figure summarizes the flow, pressure, and temperature changes during a splitless mode analysis.

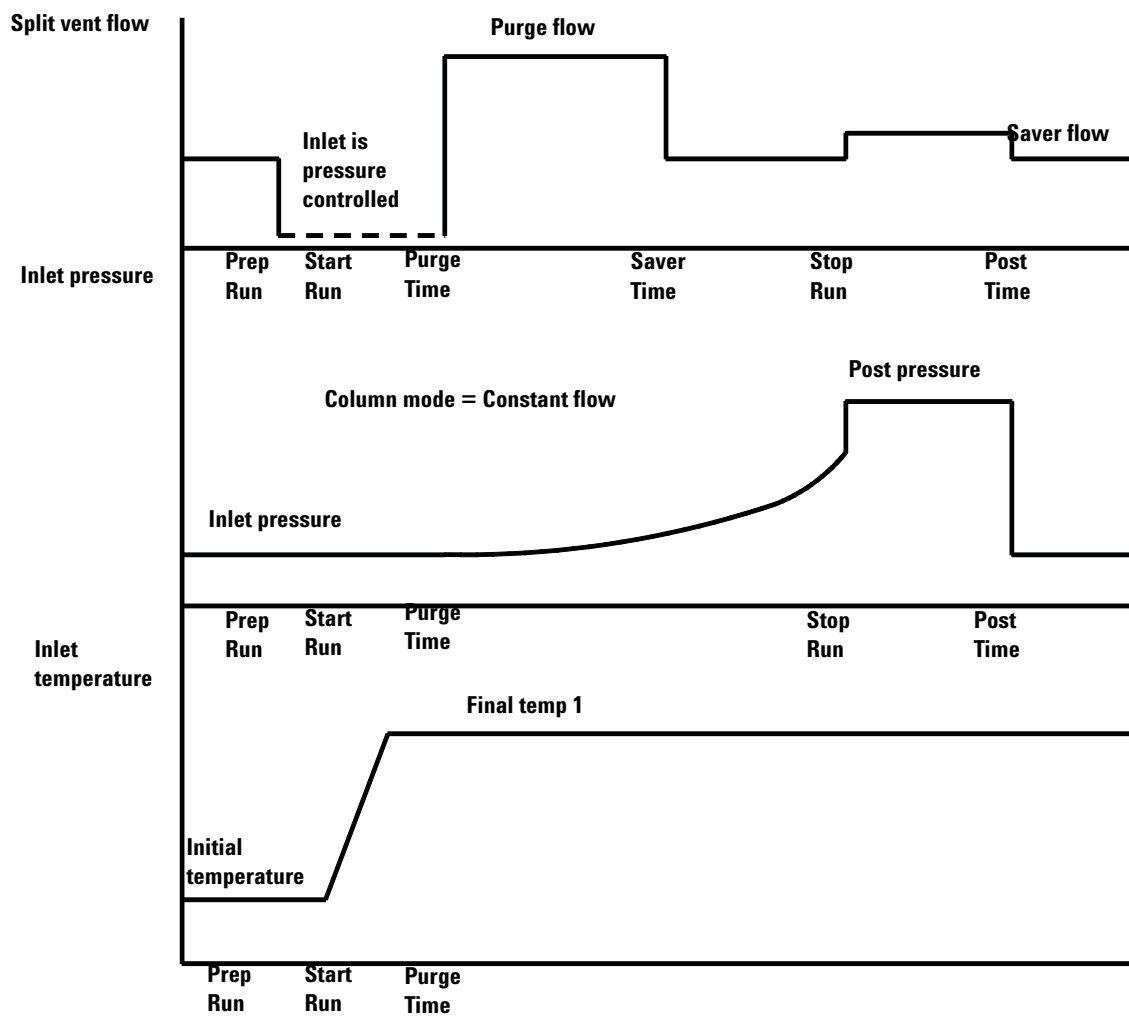

Cold splitless introduction

For cold splitless introduction, use an initial inlet temperature below the normal boiling point of the solvent. For most solvents, starting the first inlet temperature ramp at 0.1 minutes provides good transfer and reproducibility. A program rate of 500 °C/min or higher is appropriate for thermally stable analytes. A final temperature of 350 °C, held for 5 minutes, has quantitatively transferred up to C₄₄ alkane.

A main advantage of temperature programmability is that the inlet can be heated gently to transfer delicate analytes. If the oven temperature is initially low enough to refocus the analytes on the column, the inlet heating rate can be made slower (e.g., 120 °C/min). This reduces thermal degradation from the inlet and can improve peak shape and quantitation.

For most applications of cold splitless, a single temperature ramp is enough. The remaining ramps can be used to clean the liner or to decrease the inlet temperature to prepare for the next injection.

Hot splitless introduction

For hot splitless introduction, select an initial temperature high enough to volatilize the analytes. No additional temperature parameters are required as the inlet will maintain the setpoint throughout the run.

Starting values

A successful splitless injection consists of these steps:

- 1 Inject the sample and temperature program the inlet to vaporize it.
- 2 Use a low column flow and low oven temperature to create a solvent-saturated zone at the head of the column.
- 3 Use this zone to trap and reconcentrate the sample at the head of the column.
- 4 Wait until all, or at least most, of the sample has transferred to the column. Then discard the remaining vapor in the inlet—which is mostly solvent—by opening a purge valve. This eliminates the long solvent tail that this vapor would otherwise cause.
- 5 Raise the oven temperature to analyze the sample.

Some experimentation is needed to refine the operating conditions. [Table 35](#) provides starting values for the critical parameters.

Table 35 Splitless mode inlet parameters

Parameter	Allowed setpoint range	Suggested starting value
Oven temperature	No cryo, ambient+4 °C to 450 °C CO ₂ cryo, -40 °C to 450 °C N ₂ cryo, -80 °C to 450 °C	10 °C below solvent boiling point
Oven initial time	0 to 999.9 minutes	≥ Inlet purge time
Inlet purge time	0 to 200.0 minutes	$\frac{2 \times \text{Liner volume}}{\text{Column flow}}$
Gas saver time	0 to 999.9 minutes	After purge time
Gas saver flow	15 to 200 mL/min	15 mL/min greater than maximum column flow
Inlet temperature	No cryo, oven temp + 10 °C CO ₂ cryo, -70 °C to 450 °C N ₂ cryo, -160 °C to 450 °C	10 °C below solvent boiling point for 0.1min, then ramp up

Setting parameters for the splitless modes

Mode: The current operating mode—Splitless or Pulsed splitless.

Temperature Actual and setpoint inlet temperatures.

Initial time Hold time at the initial inlet temperature.

Rate # Temperature program rates for inlet thermal ramps.

Final temp # Final inlet temperature for ramp 1- 10.

Final time # Hold time at Final temp 1- 10.

Pressure Actual and setpoint inlet pressure in psi, bar, or kPa

Pulsed pres The inlet pressure you desire at the beginning of a run. The pressure rises to this setpoint after [**Prep Run**] is pressed and remains constant until **Pulse time** elapses, when it returns to **Pressure**.

Pulse time Pressure returns to its normal setpoint at this time.

Purge time The time, after the beginning of the run, when you want the split vent valve to open.

Purge flow The flow, in mL/min, from the split vent, at **Purge time**. You will not be able to specify this value if operating with your *column not defined*.

Total flow The Total flow line displays the actual flow to the inlet during a Pre- run (Pre- run light is on and *not* blinking) and during a run before purge time. You cannot enter a setpoint at these times. At all other times, Total flow will have both setpoint and actual values.

Septum purge Flow through the septum purge vent

Gas saver On to reduce split vent flow at **Saver time**

Server flow Reduced split vent flow, at least 15 mL/min

Server time Time when flow is reduced to save gas

If the column is defined

- 1 Press [**Front Inlet**].
- 2 Scroll to **Mode:** and press [**Mode/Type**]. Select **Splitless** or **Pulsed splitless**.
- 3 Set the inlet temperature and any desired ramps.
- 4 Enter a **Purge time** and a **Purge flow**.
- 5 If desired, turn **Gas saver** on. Make certain the time is set after the **Purge time**.
- 6 Press [**Prep Run**] (see “[Pre Run and Prep Run](#)” on page 171) before manually injecting a sample. This is automatic if an Agilent sampler is used.

If the column is not defined

- 1 Press [**Front Inlet**].
- 2 Scroll to **Mode:** and press [**Mode/Type**]. Select **Splitless** or **Pulsed splitless**.
- 3 Set the inlet temperature and any desired ramps.
- 4 Enter a **Purge flow**.
- 5 Enter the **Purge time** when you wish the split valve to open.
- 6 Set **Total flow** greater than the column flow plus the septum purge flow to guarantee adequate column flow.
- 7 Turn **Gas saver** on, if desired. Set the time after **Purge time**.

- 8 Press [**Prep Run**] (see “**Pre Run and Prep Run**” on page 171) before manually injecting a sample. This is automatic if an Agilent sampler is used.

MMI solvent vent mode

This mode is typically used for large volume injections. For single injection use a 50 to 500 μL syringe and the ALS variable plunger speed to slowly inject the sample.

The sample is injected into a cold inlet. If conditions are properly chosen and the sample is suitable, analytes deposit in the inlet liner while the solvent evaporates and is swept out. Large or multiple injections can be used to concentrate sample in the inlet before transferring to the column for analysis.

Stage 1. Sample and vent

During sampling and venting, the split valve is open. The inlet is at **Initial temperature**, which is at or below the solvent boiling point.

Solvent vapors are swept out the vent, while sample deposits on the liner walls or packing.

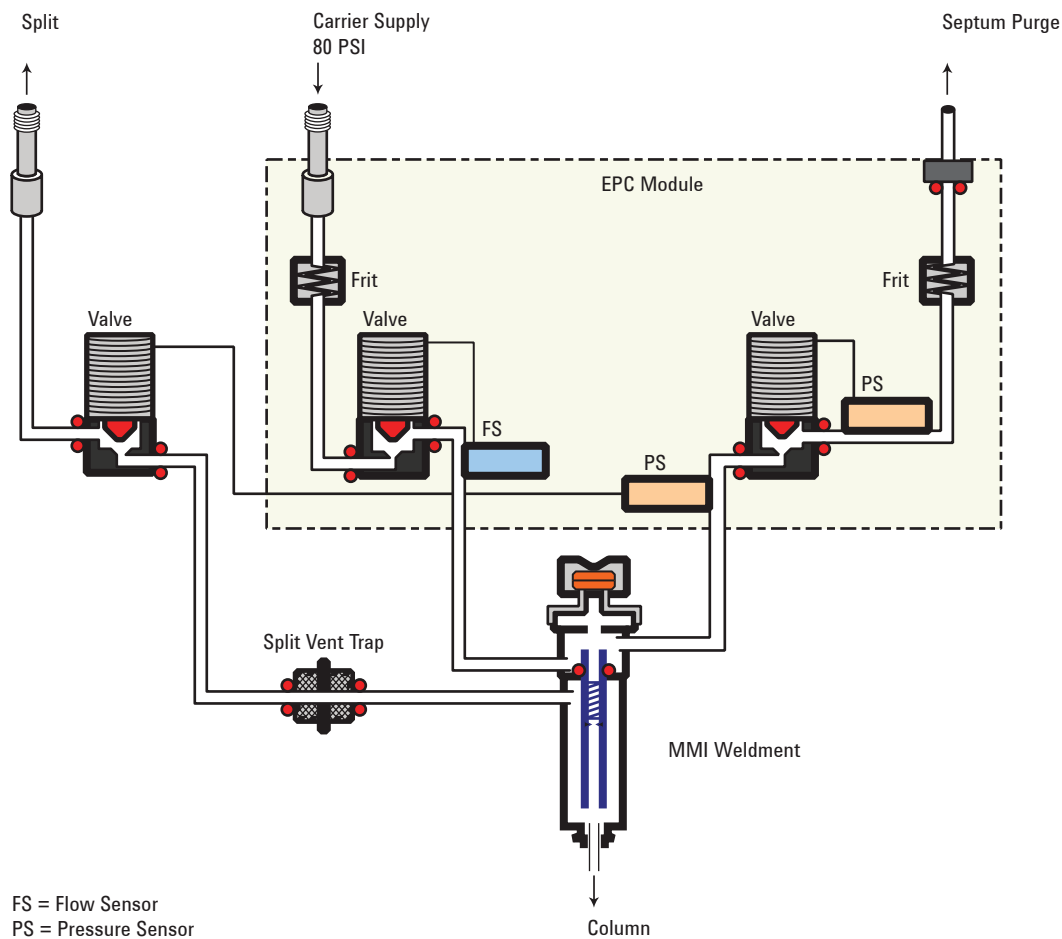

Stage 2. Sample transfer

When solvent venting ends, the split valve vent closes and the inlet heats to **Final temperature 1**. The sample transfers to the capillary column during **Purge time**. (**Purge flow to split vent** in a data system).

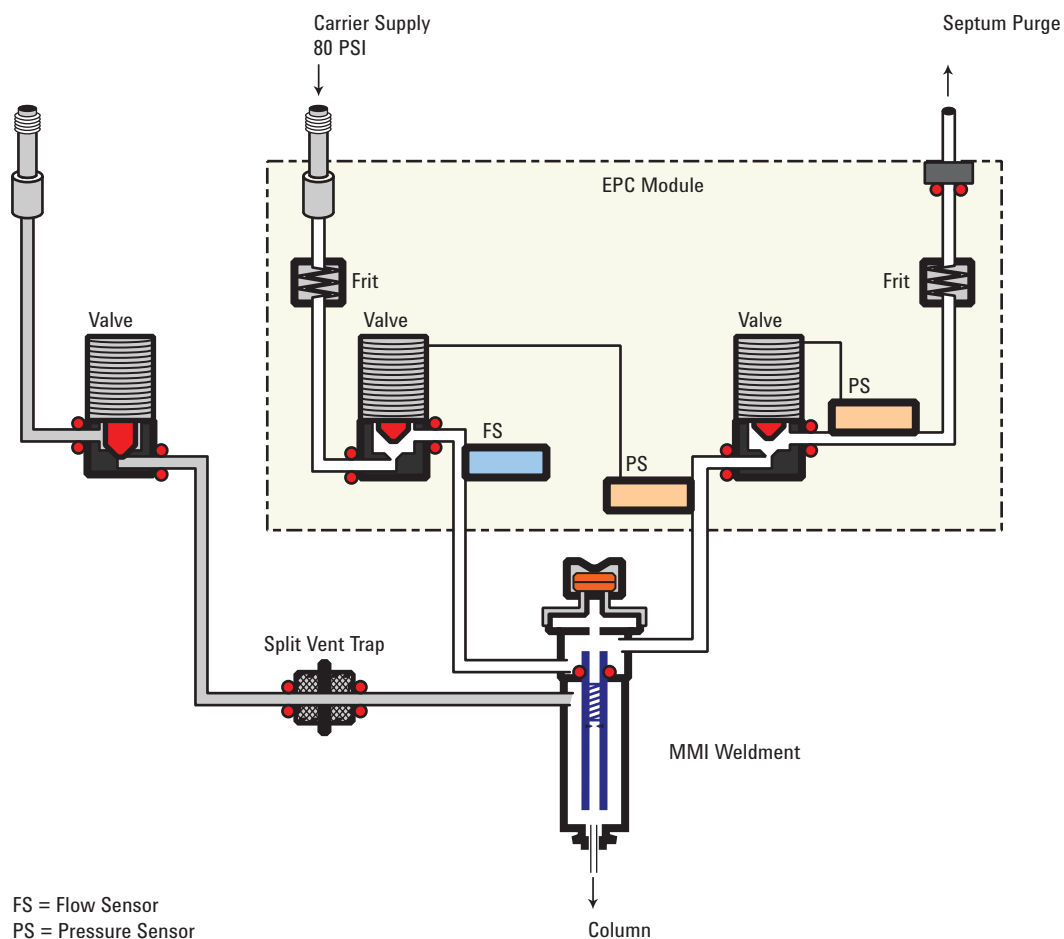

Stage 3. Purge and cleanup

The split valve opens again and the system returns to the Stage 1 configuration but with different setpoints. The MMI is flushed. Additional ramp rates are available to thermally clean the inlet or to reduce inlet temperature after sample transfer. This can extend the life of the liner.

Temperature, pressure, and flow considerations

The solvent vent mode goes through three distinct pneumatic states; venting, sample transfer, and purging. The vent portion allows the inlet pressure and the vent flow to be adjusted to optimize solvent elimination. The transfer state mimics traditional splitless operation and transports the analytes from the liner to the column. The purging mode allows the user to prepare the inlet for the next run.

A fundamental difficulty with solvent vent mode is the potential loss of volatile analytes with the solvent. Several solutions are possible for this situation:

- The inlet liner can be packed with a more retentive material, such as Tenax. This greatly improves volatile analyte recovery but may impact recovery of higher boiling materials.
- Some of the solvent can be left in the liner when sample transfer begins. The residual solvent acts like a stationary phase and retains volatile material, but at the expense of a larger solvent peak.
- The inlet temperature can be reduced. This reduces the vapor pressure of the volatile analytes and permits higher recoveries.

Solvent removal can be speeded up by:

- Reducing pressure in the inlet during sample introduction—the **Vent pressure** parameter
- Increasing flow through the inlet—the **Vent flow** parameter

While all these possibilities do complicate use of the PTV, they provide increased flexibility and new potential to solve difficult problems.

Sequence of operations

These are the steps in a typical analysis using the solvent vent mode:

Table 36 The solvent vent process

Step	Parameter	Value
1	Before injection	Flow at split vent
		Inlet pressure
The system is resting, with Purge flow (or Saver flow, if on) through the inlet.		
2	Prep Run begins	Flow at split vent
		Inlet pressure
Setpoints change to prepare for injection. When GC is ready, the sample is injected. Inlet and oven temperature program Init times begin. Solvent venting and analyte trapping begin.		
3	At Vent end time	Flow at split vent
		Inlet pressure
Solvent venting ends, analyte transfer begins as inlet heats up.		
4	At Purge time	Flow at split vent
		Purge flow setpoint

Table 36 The solvent vent process (continued)

Step	Parameter	Value
	Inlet pressure	Column pressure setpoint
Analyte transfer ends, inlet is purged of residual vapor. Analysis begins.		
5	At Saver time	
	Flow at split vent	Saver flow setpoint
	Inlet pressure	Column pressure setpoint
Analysis ends, carrier flow reduced to save gas (if Saver is on).		

Some important points

- The flow through the column is governed by the pressure in the inlet. This is controlled, during the analysis part of the process, by the flow or pressure setpoint or program entered *for the column*.
- The controlling times must be in the order shown; Vent end time *before* Purge time, and Purge time *before* Saver time.
- Vent end time must occur before the inlet starts to heat and release analytes.
- Purge time must occur before the oven begins to heat and move sample through the column.

Timelines

Time increases downward; all other quantities increase to the right.

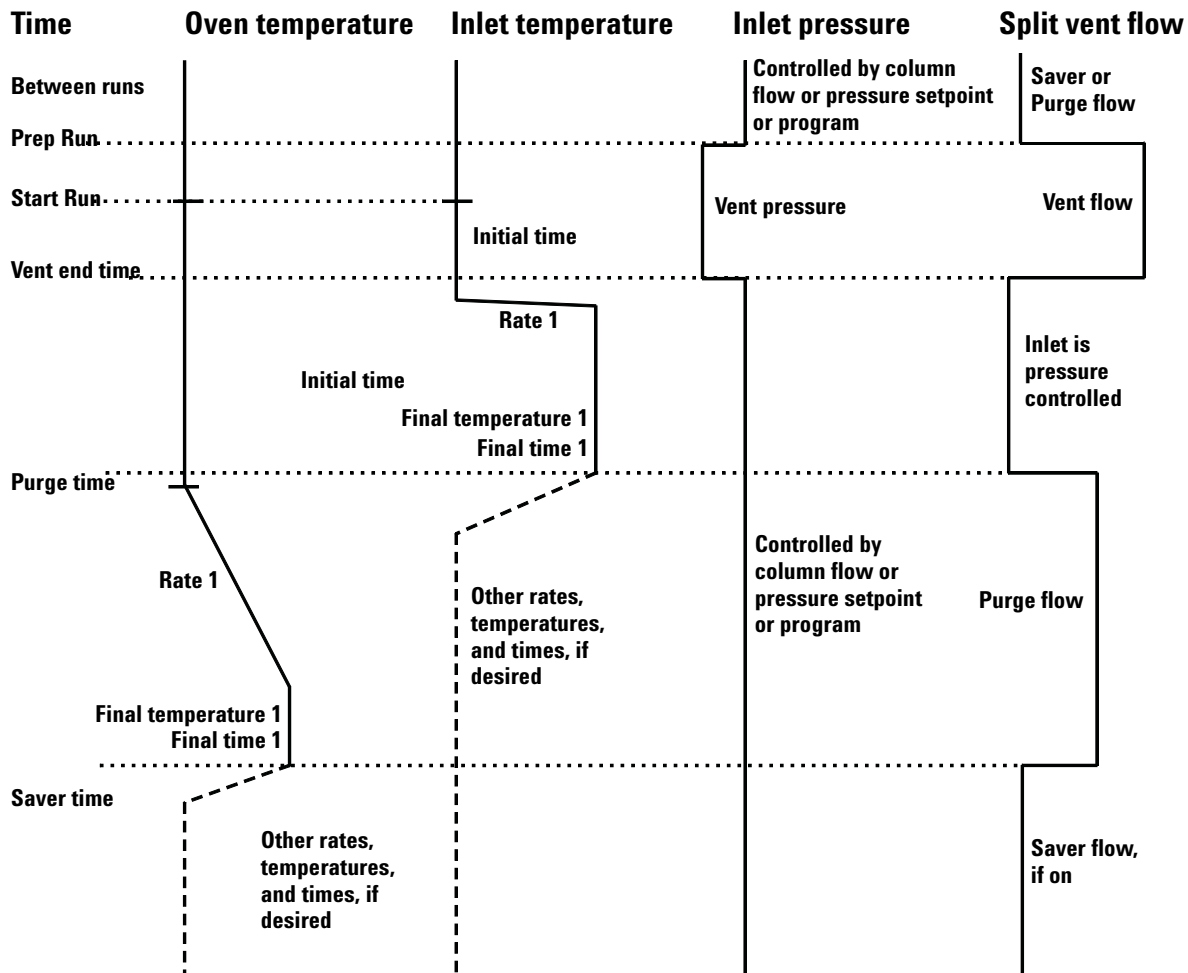

When is Start Run?

Both the inlet and oven temperature programs begin at Start Run. All times—such as Purge time—are measured from Start Run. When does Start Run occur?

- If the sample is injected manually, Start Run occurs when the user presses the **[Start]** key.
- If a single injection per run is made using an autosampler, Start Run occurs when the syringe carrier moves down to make the injection.
- If multiple injections per run are made using an autosampler, Start Run occurs when the syringe carrier moves down to make the first injection of the set. There are no Start Run signals for the rest of the injections in the set.

These additional injections take time. The inlet and oven temperature programs, mainly the **Initial time** values, must be adjusted to allow for this. So must the various time values that

control the inlet operation. This is discussed in more detail under “[To develop a MMI method that uses large volume injection](#)” on page 210.

Setting parameters for solvent vent operation

Mode: The current operating mode—solvent vent.

Temperature Actual and setpoint initial inlet temperatures.

Initial time The time, measured from Start Run, when the initial inlet temperature hold ends. Must be greater than **Vent end time**.

Rate # Temperature program rate for inlet thermal ramps.

Final temperature # Final inlet temperature for ramp 1- 10.

Final time # Hold time at **Final temp #**. This time is a duration; it is *not* measured from Start Run.

Pressure Actual and setpoint inlet pressure before and after the vent period. It sets the starting point of column head pressure.

Vent pressure The inlet pressure during the vent period. By decreasing the inlet pressure while venting, solvent elimination proceeds faster. Also, the pressure reduction decreases the amount of carrier gas—and solvent vapor—that enters the column during this time.

Users select from 0 to 100 psig. If 0 is chosen, the inlet uses the lowest pressure possible at the given vent flow. [Table 37](#) shows approximate values for this minimum at various vent flows of helium. Pressures less than those in the table are not possible unless the flow is reduced.

Table 37 Minimum attainable pressures

Vent flow (mL/min)	Actual vent pressure at “0” psig setpoint	Actual vent pressure at “0” kPa setpoint
50	0.7	5
100	1.3	10
200	2.6	18
500	6.4	44

Table 37 Minimum attainable pressures

Vent flow (mL/min)	Actual vent pressure at "0" psig setpoint	Actual vent pressure at "0" kPa setpoint
1000	12.7	88

Vent flow The flow of carrier gas out the split vent during the vent period. Higher flows sweep the liner more quickly and reduce the time for solvent elimination. For most columns, 100 mL/min vent flow eliminates solvent at an acceptable rate but puts minimal material on the column.

Vent end time The time, measured from Start Run, when solvent venting ends. For large volume injections, this time is normally greater than the time for the injection to complete.

Purge time The time, measured from Start Run, when sample transfer ends. It began at **Vent end time**.

Purge flow The flow of carrier gas to the inlet beginning at **Purge time**.

Total flow The actual flow into the inlet.

Septum Purge Flow through the septum purge vent

Gas saver On to reduce split vent flow at **Saver time**

Saver flow Reduced split vent flow, at least 15 mL/min

Saver time Time when flow is reduced to save gas

If the column is defined

- 1 Press [**Front Inlet**].
- 2 Scroll to **Mode:** and press [**Mode/Type**]. Select **Solvent vent**.
- 3 Enter a **Vent pressure**, a **Vent flow**, and a **Vent end time**.
- 4 Set the inlet temperature and ramps, as desired.
- 5 Enter a **Purge time** and a **Purge flow**.
- 6 If desired, turn **Gas saver** on. Make certain the time is set after the **Purge time**.
- 7 Press [**Prep Run**] (see "Pre Run and Prep Run" on page 171) before manually injecting a sample.

If the column is not defined

- 1 Set up the parameters as described for the defined column case.
- 2 Set **Total flow** greater than the column flow plus the septum purge flow to guarantee adequate column flow.

MMI Direct Mode

MMI Direct Mode is a pneumatic configuration that allows on-column like behavior. In this mode, you still use a liner to trap involatile material but the sample can only enter the column.

Direct mode works best with direct connect liners. These liners form a seal with the column so that the sample cannot leak out of the liner. The inlet is held at a temperature below the solvent boiling point, just as in cool on-column (COC) during the injection. Pneumatically, the inlet is in forward pressure regulation, similar to the splitless portion of splitless mode. The inlet is then temperature programmed to transfer any remaining volatile material to the column.

The only control parameter for Direct Mode is inlet pressure. You can run the column in any of its normal control modes (constant pressure, constant flow, ramped pressure, ramped flow). Gas saver does not work in this mode as there is no purge state.

The next figure shows the flows with direct mode.

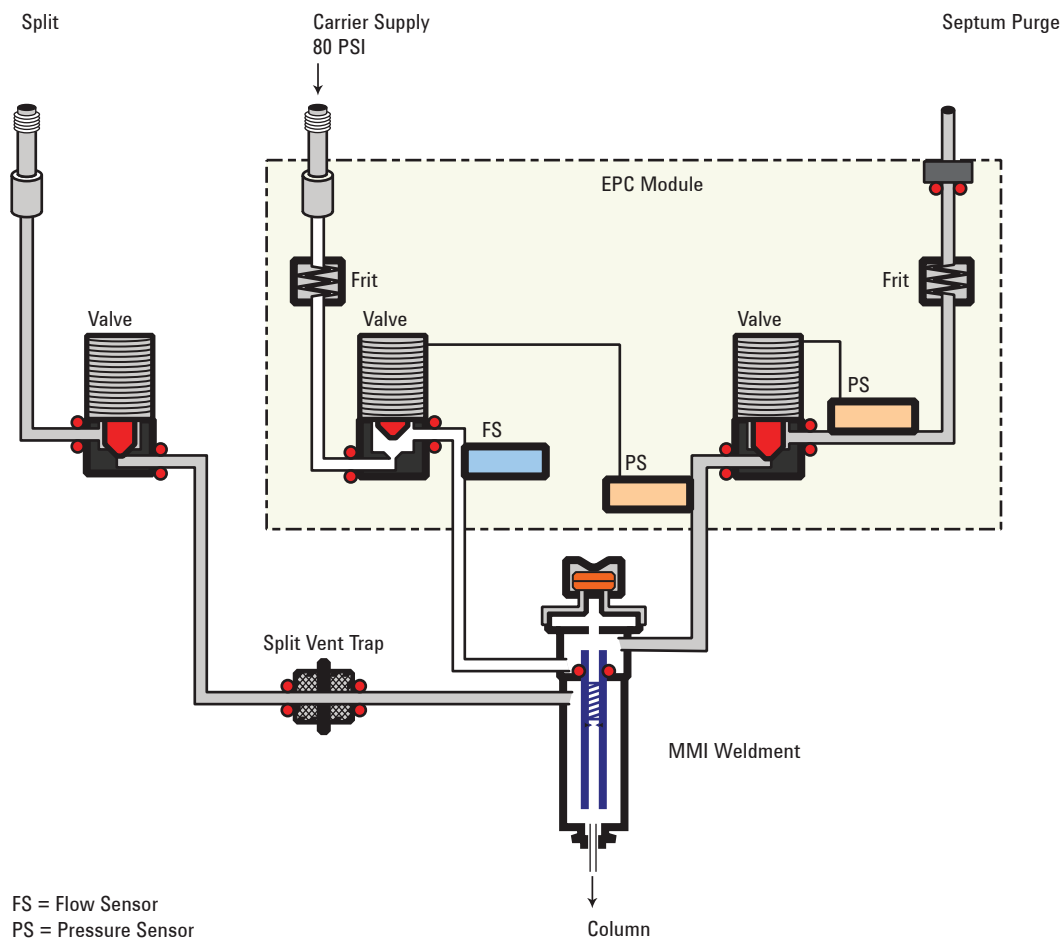

To develop a MMI method that uses large volume injection

This topic provides a recommended way to change from a splitless injection using a split/splitless inlet to a solvent vent mode injection using a Multimode inlet (MMI). It applies mainly to large volume injections (LVI) using a Multimode inlet, but the concepts can apply to general MMI use. This topic does not consider all items that can impact an analysis, for example the liner, solvent, analyte boiling points, or polarity. This topic also assumes knowledge of your data system—when to save a method, how to start a run, how to set up a single run, etc.

The main advantage of the MMI's solvent vent mode is that you can inject slowly into the inlet, allowing large amounts of solvent to evaporate in the liner (not in the split vent line),

concentrating the analytes prior to injection. This requires an injector with variable speed injections, a "large" syringe, and knowledge of the sample and the solvent. When developing a solvent vent method, the goal for the injection is to determine the injection rates and temperatures needed to evaporate the solvent at the rate it enters the inlet. The development technique is to gradually scale up to an injection amount that produces a useful response. The most significant parameters are:

Inlet temperature. Hold the inlet temperature at or slightly below the solvent boiling point until after all the sample has been injected. This is important so that you do not boil away more volatile analytes, or boil away the solvent in the needle and trap your analytes there. An additional point to consider is that the boiling point of the earliest eluting analyte should be $100\text{ }^{\circ}\text{C} >$ the boiling point of the solvent.

Injection speed. Estimate the evaporation rate of solvent exiting the needle based on solvent type, inlet temperature, vent flow, and pressure. Start with about half that number. Note that you have to make sure that you configure the syringe properly. If not, you will over- or under- load the inlet.

Vent time. Make sure the vent time setpoint is greater than the time the needle spends in the inlet. If the vent time is too short, you will overload and contaminate the column and inlet. Change the vent time as you upscale the method.

If using a MMI with an MSD, another tip for method development is to scan for solvent ions. Detecting the solvent ions can be useful in troubleshooting residual solvent bleed onto the column.

To develop a MMI method for large volume injection, try the following:

- 1 Determine a small injection volume that works on a split/splitless inlet in splitless mode. Choose a volume that does not currently overload the inlet.
- 2 Start with a 5–10 μL syringe and make sure the syringe is properly configured in the instrument and data system.
- 3 Make sure the column is configured.
- 4 Set up the inlet to perform a 1 μL injection. Use the split/splitless inlet method conditions, except:

- Start with the inlet temperature cold, near but slightly below the solvent boiling point. For example, if using methylene chloride (boiling point 39 °C), start with a temperature of 30–39 °C.
 - Use Splitless mode.
 - Ramp to the normal split/splitless inlet temperature
- 5 Note the response achieved.
 - 6 Next, change the inlet mode to Solvent Vent.
 - 7 Check the injector timings.
 - a Install an empty sample vial in the injector turret or tray.
 - b Input the injection rate (Draw, Dispense, and Inject rates) for the injector and increase the injection volume to 5 uL.
 - c Enter draft Solvent Vent parameters:
 - Set a Vent Flow of 100 mL/min as a starting point.
 - Keep the inlet isothermal for now
 - Enter a Vent Pressure of 0 psi (0 kPa) until 0.1 min.
 - Make an injection using the empty vial. Use a stopwatch or your GC's timer feature to time how long the needle is in the inlet.
 - 8 Enter revised Solvent Vent mode parameters.
 - Set the method's Vent Time to be about 0.05 min longer than the time the needle spends in the inlet.
 - Set the inlet temperature initial Hold Time to be about 0.05 min longer than the vent pressure until time.
 - Program the inlet to ramp quickly to the injection temperature. Make sure the ramp starts after the vent pressure until time.
 - Set the Purge Flow to Split Vent to 30 mL/min. Set the purge time to be the vent pressure until time + 1 minute.
 - 9 Make a 5 uL injection of your standard. You should see 5 times the response.

If the response of all analytes is too low:

- The dispense speed is too fast. Liquid was injected into the inlet and pushed out the vent.
- The vent time is too long. The inlet started to heat while the vent was open.

If the response of early eluters is too low:

- The inlet temperature is too high.

- The Vent Flow is too high.

If the response of late eluters is too low:

- The purge time is too short.
 - The final inlet temperature is too low.
- 10 If you need more injection volume and the 5 uL worked to give 5X response, change the syringe to a larger one, for example 50 uL.
 - 11 Set up the data system to perform a 25 uL injection.
 - 12 Configure the syringe. Make sure the plunger speeds on the injector are still set properly.
 - 13 Recheck the injector timings. See [step 12](#).
 - 14 Set a new vent time and initial inlet temperature time based on the new time the needle spends in the syringe.
 - 15 Make a 25 uL injection of your standard. Again, you should see 5 times the response. If not, see [step 13](#).
 - 16 If you need more response, repeat steps 10 – 15 to increase to larger volume. Also try performing 5 x 5 uL injections, then 5 x 50 uL injections.

Multiple injections with the MMI

The preferred technique for concentrating analytes in the inlet liner is to use a single, large volume injection. Using a high capacity syringe and one septum puncture reduces the possibility of contamination and generally improves results when compared against a multiple septum puncture technique. However, if needed, you can perform multiple septum punctures during the vent time. This technique requires an Agilent data system and automatic liquid sampler.

Data system requirements

An Agilent data system is necessary for multiple injection because the needed parameters are not available through the GC keyboard.

GC ChemStation Software revision B.04.01 SP1 or later.

MSD ChemStation Software revision E.02.00 SP2 or later

EZChrom Software revision 3.3.2 or later

Setting parameters for the inlet in solvent vent mode

Set or configure the following parameters in the data system's 7890A GC method editor.

Syringe size – Verify the syringe size is configured correctly. The configured syringe size changes the available choices for injection volume.

Injection volume – Select the injection volume, then enter a number of injections. The total injection volume will be displayed.

Multiple Injection Delay – A pause time, in seconds, between injections. This is added to the minimum hardware cycle time.

Preinjection washes and pumps are performed only before the first injection of a multiple injection set.

Postinjection washes are performed only after the last injection in a multiple injection set.

An example

These values were used for a sample with a broad range of boiling points.

Table 38 General parameters

Name	Value
Sample	C ₁₀ to C ₄₄ hydrocarbons in hexane
Mode	Solvent vent
MMI liner	Glass wool packed
Injection volume	One 10.0 µL injection (25 µL syringe)
Injection speed	Fast
Column	30 m x 320 µm x 0.25 µm -5, part number 19091J-413
Column flow	4 mL/min constant flow

Table 39 Inlet parameters

Name	Value	Name	Value
Initial temp	40 °C	Rate 2 (off)	
Initial time	0.3 min	Pressure	15.6 psig
Rate 1	720 °C/min	Vent pressure	0.0 psig

Table 39 Inlet parameters

Name	Value	Name	Value
Final temp 1	450 °C	Vent flow	100 mL/min
Final time 1	5 min	Vent end time	0.2 min
Rate 2	100 °C/min	Purge time	2.0 min
Final temp 2	250 °C	Purge flow	50 mL/min
Final time 2	0 min		

Table 40 Oven parameters

Name	Value
Initial temp	40 °C
Initial time	2.5 min
Rate 1	25 °C/min
Final temp 1	320 °C
Final time 1	10.0 min
Rate 2 (off)	

Table 41 Detector parameters

Name	Value
Detector	FID
Detector temp	400 °C
Hydrogen flow	40 mL/min
Air flow	450 mL/min
Makeup (N ₂)	45 mL/min

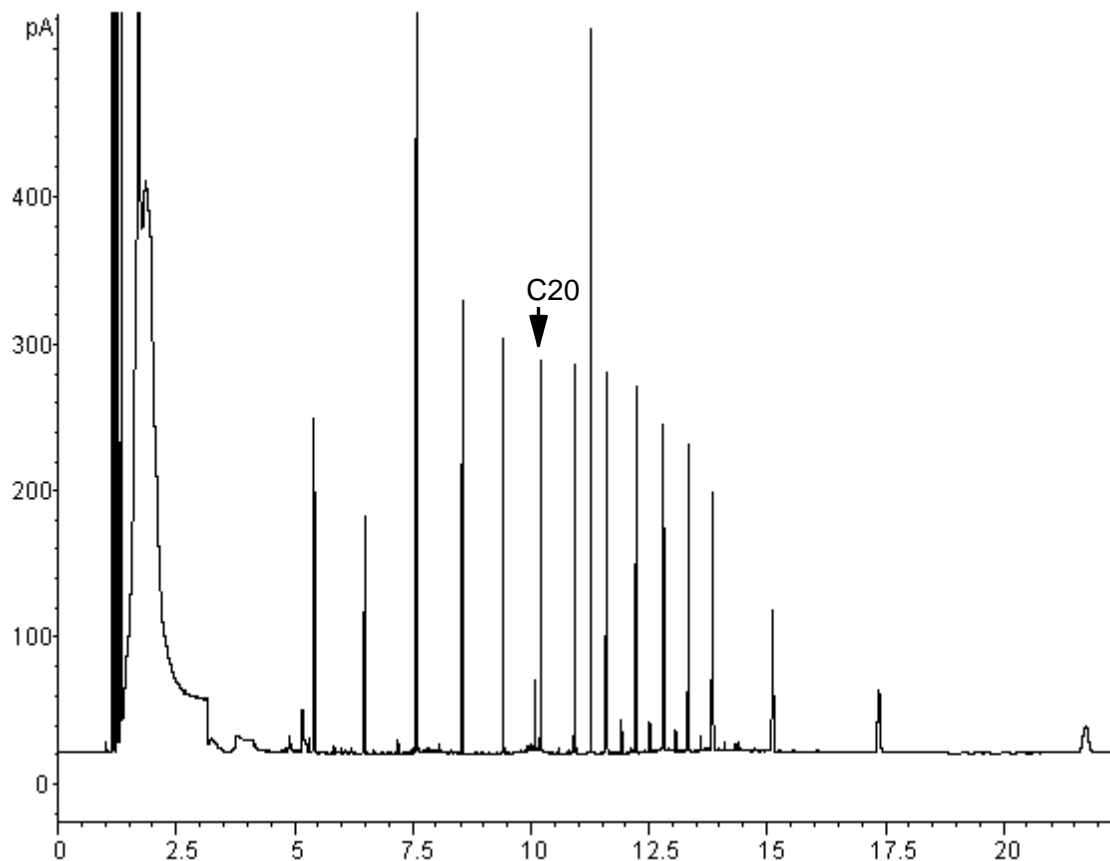

These results were compared with a splitless analysis of the same sample, which should produce 100% recovery of all analytes. The data showed that, under these conditions, compounds above C₂₀ were completely recovered and that the recovery was independent of injection size. Compounds lower than C₂₀ were partially vented with the solvent.

Possible adjustments

Depending on what you are trying to accomplish, you have a number of possible adjustments available.

To eliminate more solvent

- Increase the vent end time, inlet initial time, and purge time. This will not affect analytes that are quantitatively trapped but will eliminate more of the solvent peak.
- Increase the vent flow to sweep the liner more rapidly with the same inlet timing. Increasing vent flow raises vent pressure if it is set to 0. This puts more solvent onto the column.

- Raise the inlet initial temperature to vaporize more solvent and allow more to be eliminated. This also increases the loss of volatile analytes since their vapor pressures also increase.

To improve recovery of low boiling analytes

- Reduce inlet temperature to lower the vapor pressure of the analytes and trap them more effectively. This also reduces solvent vapor pressure and more time will be needed to eliminate it.
- Use a retentive packing in the liner. Materials such as Tenax permit higher recovery of volatile analytes but may not release higher boiling compounds. This must be considered if quantitation on these high boiling peaks is desired.
- Leave more solvent in the liner. The solvent acts as a pseudo stationary phase and helps retain volatile analytes. This must be balanced against the detector's tolerance for solvent.

An example—continued

The single injection example shown on the last few pages makes it clear that a 10 μL injection does not overload the glass wool packed liner. This means that multiple 10 μL injections are possible.

It was decided to make 10 injections per run, each of 10 μL size. This would increase analytical sensitivity substantially. No adjustments were made to improve recovery of the low boilers since the purpose of this analysis was to detect and measure the high boiling components.

After timing a trial set of 10 injections, the total time for the multiple injection set was measured to be approximately 1.3 minutes. The following timing changes were made:

Table 42 Modifications

Parameter	Increased from	To
Inlet Init time	0.3 minutes	1.6 minutes
Vent end time	0.2 minutes	1.5 minutes
Purge time	2.0 minutes	3.0 minutes
Oven Init time	2.5 minutes	3.0 minutes

The result is shown in the next figure. Note the difference in the vertical scale (5000 versus 500).

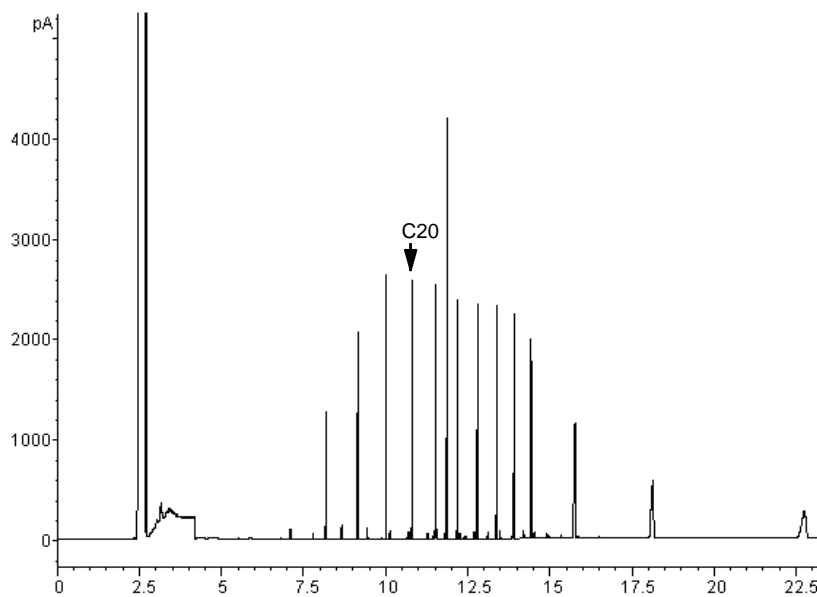

About the Packed Column Inlet

This inlet is also known as the purged packed inlet (PP). It is used with packed columns when high- efficiency separations are not required. It can also be used with wide- bore capillary columns, if flows greater than 10 mL/min are acceptable.

If the columns are not defined (packed columns and undefined capillary columns), the inlet is usually flow- controlled. If capillary columns are used and the columns in the flow path are defined, the inlet is normally pressure- controlled but can be put into the flow control mode.

The figure shows the inlet in the capillary column mode, with the column defined and the flow controlled by pressure.

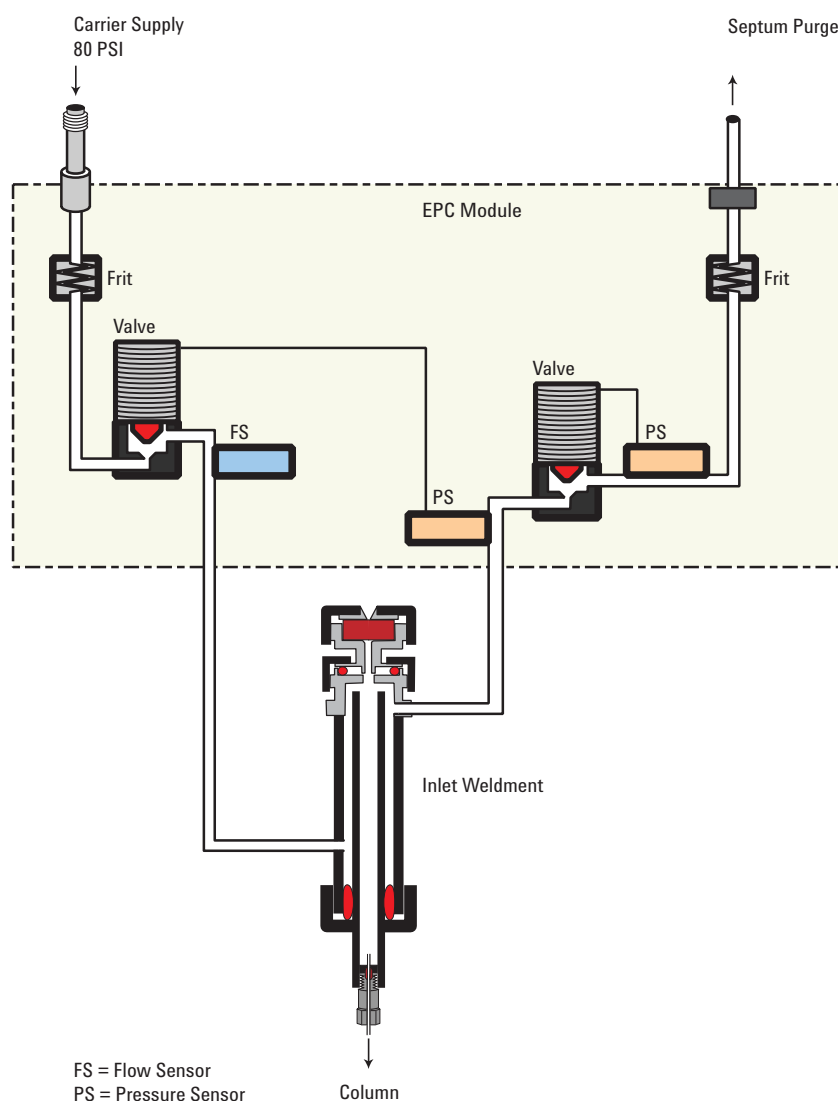

The next figure shows the flow diagram for the packed column mode, with the column not defined the control is based on total carrier gas flow.

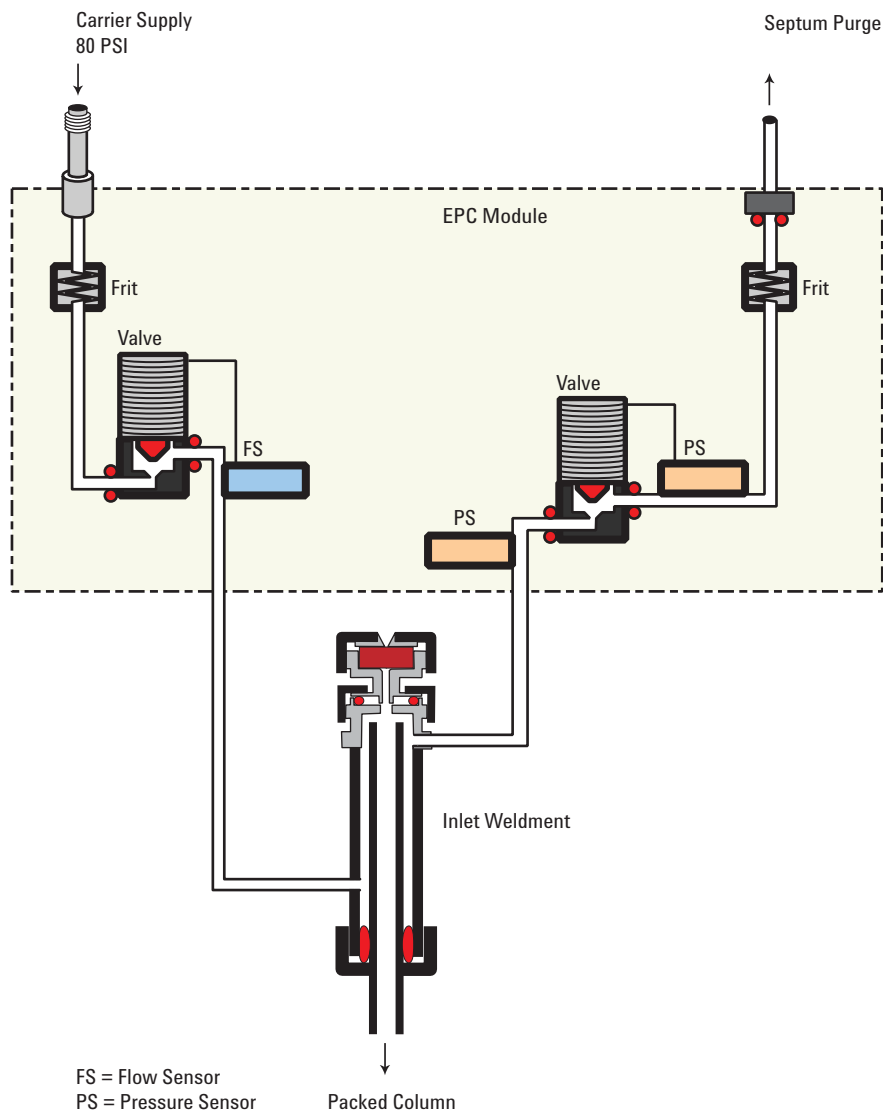

Setting parameters

The inlet can operate in flow or pressure control mode. Flow is recommended for packed columns. Pressure is recommended for capillary columns.

Inlet in flow control mode

While in flow control mode, you cannot enter pressures here.

Mode Press [**Mode/Type**] to see the choices. You may select an inlet mode of either **Pressure control** or **Flow control**. When the Inlet control mode is **Pressure control**, the column control mode can be set to **Constant pressure, Ramped pressure, Constant flow, or Ramped flow**. The column control mode is set from the Column parameters display. When the Inlet control mode is **Flow control**, only column flow can be set on the Column parameters display.

Temperature The setpoint and actual temperature values.

Pressure The actual pressure (in psi, bar, or kPa) supplied to the inlet. You cannot enter a setpoint here.

Total flow Enter your setpoint here, actual value is displayed. Inlet is mass flow controlled.

Septum purge The setpoint and actual flow, in mL/min, through the septum purge line, typically 1 to 5 mL/min

Inlet in pressure control mode

While in pressure control mode, you cannot enter flows here.

Mode Press [**Mode/Type**] to see the choices. You may select an inlet mode of either **Pressure control** or **Flow control**. When the Inlet control mode is **Pressure control**, the column control mode can be set to **Constant pressure, Ramped pressure, Constant flow, or Ramped flow**. The column control mode is set from the Column parameters display. When the Inlet control mode is **Flow control**, only column flow can be set on the Column parameters display.

Temperature The setpoint and actual temperature values of the inlet.

Pressure Enter your setpoint here (in psi, bar, or kPa). The actual value is displayed.

Total flow The actual total flow to the inlet. This is a reported value, not a setpoint.

Septum purge The setpoint and actual flow, in mL/min, through the septum purge line, typically 1 to 5 mL/min

About the Cool On-Column Inlet

This inlet introduces liquid sample directly onto a capillary column. To do this, both the inlet and the oven must be cool at injection, either at or below the boiling point of the solvent.

Because the sample does not vaporize immediately in the inlet, problems with sample discrimination and sample alteration are minimized. If done properly, cool-on column injection also provides accurate and precise results.

You can operate the inlet in track oven mode, where the inlet temperature follows the column oven, or you can program up to three temperature ramps. A cryogenic cooling option that uses liquid CO₂ or N₂ from the oven cryogenic system can reach sub-ambient temperatures.

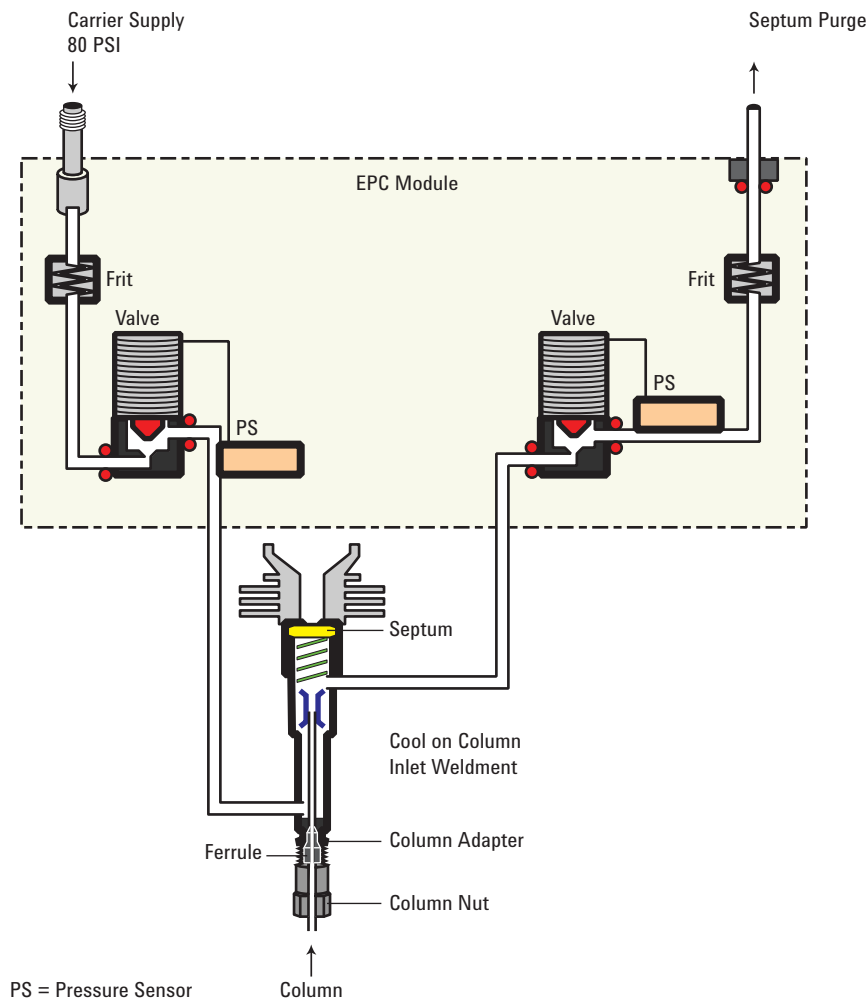

Setup modes of the COC inlet

The COC inlet hardware must be set up for one of three usages, depending on the type of injection and column size.

- 0.25 mm or 0.32 mm automated on- column. Use predrilled septa.
- 0.53 mm automatic on- column or retention gap
- 0.2 mm manual

To select the correct hardware for a column and injection type, refer to [Maintaining Your GC](#).

Retention gaps

Because the sample is injected directly onto the column, it is strongly suggested that a retention gap—or guard column—be used to protect your column. A retention gap is a deactivated column that is connected between the inlet and the analytical column. If you choose to use one, it is suggested that at least 1 m of retention gap be installed per 1 μ L of sample injected. Information on ordering retention gaps can be found in the Agilent catalog for consumables and supplies.

If you are using a retention gap and are operating with the column defined, the length of the retention gap could affect the calculations for flow and velocity through your column. If your retention gap is the same inside diameter as your column, it is a good idea to add the retention gap and column length before entering the number on the Configure Column parameter list. If the retention gap inside diameter is larger than your column, this step may not be necessary.

COC inlet temperature control

CryoBlast (optional)

CryoBlast shortens the cycle time between runs. If you have a CO₂ or N₂ cryogenic valve and the CryoBlast feature, you can cool the inlet to -37 °C in either the track oven or temperature program modes.

The CryoBlast accessory uses coolant from the oven cryogenic system.

Track oven mode

In the **Track oven** mode, the inlet temperature stays 3 °C higher than the oven temperature throughout the oven program. You cannot enter a temperature setpoint—it is set automatically. If you have CryoBlast, the inlet will track oven temperatures to -40 °C; without CryoBlast, the lower limit is set by room temperature.

Temperature programming mode

In this mode, you can enter up to three temperature ramps in the inlet parameter list so that the inlet and the oven operate independently. This is the recommended mode if operating below -20 °C.

At these very low oven temperatures, the inlet temperature should be at least 20 °C higher than the oven temperature. This will be more than adequate for solvent focusing.

At temperatures greater than ambient, the inlet should always be at least 3 °C warmer than the oven for proper control of the inlet temperature.

The oven temperature program controls the run. If it is longer than the inlet temperature program, the inlet will remain at its final temperature until the oven program (and the run) ends.

Cryogenic considerations

When using track oven mode with a cryogenic oven, all other inlets must be off or in track oven mode.

If cryo is turned on, and if the inlet is cooled during a run, cryogen is used to achieve the setpoint. This may have a negative impact on the chromatographic performance of the oven and cause distorted peaks.

The inlet uses the same cryo coolant as configured for the oven.

Setting COC inlet flows/pressures

- 1 Configure capillary column to inlet—select constant flow or pressure.
- 2 Set column flow, linear velocity, or inlet pressure.
- 3 Set Septum Purge, typically 3 to 10 mL/min.

Setting COC inlet parameters

Track oven mode

- 1 Press [**Front Inlet**] or [**Back Inlet**].
- 2 Press [**Mode/Type**] and select **Track oven**.

There is no setpoint for **Track oven** mode.

Ramped temperature mode

- 1 Press [**Front Inlet**] or [**Back Inlet**].
- 2 Press [**Mode/Type**] and select **Ramped temp**.
- 3 Enter a value for **Temp**. This is the starting temperature.
- 4 Enter an **Init time**. This is the length of time the inlet will stay at the starting temperature after a run has begun.
- 5 Enter **Rate 1**. This is the rate at which the inlet will be heated or cooled. A Rate of **0** halts further programming.
- 6 Enter **Final temp 1**. This is the inlet temperature at the end of the first ramp.
- 7 Enter **Final time 1**. This is the number of minutes the inlet holds **Final temp 1**.
- 8 To enter a second (or third) ramp, scroll to the appropriate **Rate** line and repeat steps 5 through 7.

About the PTV Inlet

The Agilent Programmed Temperature Vaporization (PTV) Inlet System has five operating modes:

- The *split mode* is generally used for major component analyses.
- The *pulsed split mode* is like the split mode, but with a pressure pulse applied to the inlet during sample introduction to speed the transfer of material to the column.
- The *splitless mode* is used for trace analyses.
- The *pulsed splitless mode* allows for a pressure pulse during sample introduction.
- The *solvent vent mode* is used for large volume injection. Either single or multiple injections can be made for each run.

The PTV inlet can be used with both manual and automatic injection.

For automatic multiple injections (large volume injections), an Agilent GC or MSD ChemStation is required. This function is not available under GC control alone. See [“PTV inlet solvent vent mode”](#) on page 239.

PTV sampling heads

Two heads are available for the PTV inlet.

The septum head uses either a regular septum or a Merlin Microseal™ to seal the syringe passage. A stream of gas sweeps the inner side of the septum and exits through the septum purge vent on the pneumatics module. It may be used with either automatic or manual injection.

The septum head uses either standard 11 mm septa or (with a different cap) a Merlin Microseal.

The septumless head uses a check valve instead of a septum to seal the syringe entrance passage. It may be used with either automatic or manual injection. This head is recommended for subambient inlet operation.

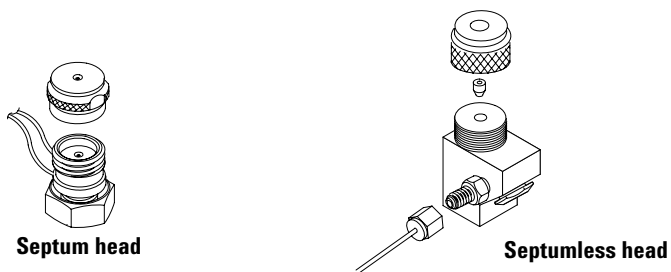

The flow diagrams in the rest of this document show the septum head in place with a separate drawing for the septumless head.

Heating the PTV inlet

The control parameters for PTV temperature programming are the same as for the column oven, but are reached by pressing **[Front Inlet]**. Temperature can be programmed with an initial temperature and up to 3 rates and plateaus. Rates between 0.1 and 720 °C/min can be selected. See [“Setting COC inlet parameters”](#) on page 225 for details.

At the end of the run and during post-run, the PTV is held at its final temperature. This permits backflushing without contaminating the inlet.

CAUTION

If the initial inlet temperature and the oven initial temperature are too close, the inlet may be unable to maintain its setpoint. We recommend a difference of at least 6 °C, either higher or lower.

Additional temperature ramps

For most purposes, the PTV is designed to hold the sample in the inlet liner until the entire sample—there could be several injections—has been injected. Then the PTV is heated rapidly to transfer the sample to the column. This can be accomplished with an initial hold, a single ramp, and a hold at the end to complete sample transfer.

Two additional ramps are available and have several possible uses:

- The inlet can be heated to a high temperature to thermally clean the liner for the next run.
- The inlet can be programmed downward—just set the Final temp below the previous temperature—to reduce thermal stress on the inlet.

- Downward programming can be used to prepare the inlet for the next run. This can reduce cycle time for greater sample throughput.

Cooling the PTV inlet

If cryo is turned on, and if the inlet is cooled during a run, cryogen is used to achieve the setpoint. This may have a negative impact on the chromatographic performance of the oven and cause distorted peaks.

The sample may be injected into either a cooled or heated inlet. The initial inlet temperature can be reduced to $-60\text{ }^{\circ}\text{C}$ (with CO_2 cooling) or to $-160\text{ }^{\circ}\text{C}$ (with liquid N_2 cooling).

The inlet uses the same coolant as configured for the oven.

PTV inlet split and pulsed split modes

The two split modes—with or without a pressure pulse—divide the gas stream entering the inlet between the column flow, the split vent flow through the solenoid valve, and the septum purge flow. The ratio of the split vent flow to the column flow is called the split ratio.

The next figure shows the flows with the septum head. Flows with the septumless head are the same except that the septum purge flow bypasses the head.

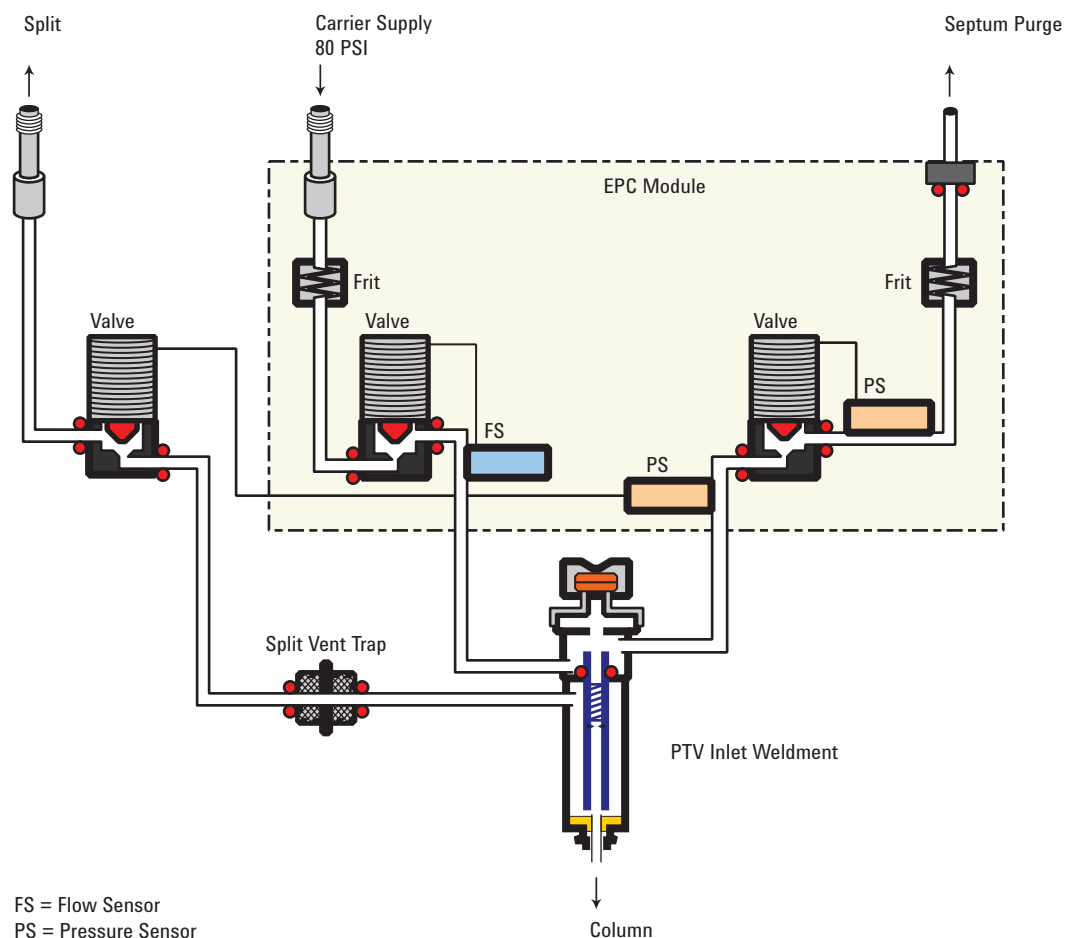

Cold split introduction

For cold split sample introduction, use an initial inlet temperature below the normal boiling point of the solvent. If the liner volume is enough to hold all the vaporized solvent, start the first inlet temperature ramp at 0.1 minutes with a high heating rate (500 °C/min or higher). The final temperature should be high enough to volatilize the heaviest analytes from the liner and should be held for at least 5 minutes. A final temperature of 350 °C for 5 minutes has proven sufficient to quantitatively transfer C₄₄.

For larger injection volumes or to eliminate the solvent, hold the initial temperature long enough to vent the solvent through the split vent and then begin the first ramp. Use a fast rate for thermally stable analytes. Slower rates may help minimize thermal degradation in the inlet.

A single temperature ramp is enough for the injection process. The remaining ramps may be used to clean the liner or to reduce the inlet temperature in preparation for the next injection.

Hot split introduction

For hot split introduction, set an initial temperature high enough to volatilize the analytes. No additional thermal parameters are required as the inlet will maintain the setpoint throughout the run.

Because of the small liner volume (about 120 microliters), the PTV has a limited injection capacity with hot split introduction. Injection volumes exceeding 1 μL in the hot split mode may overflow the inlet causing analytical problems. Cold split introduction avoids this potential problem.

Setting parameters for split mode operation

Mode: The current operating mode—split or pulsed split

Temperature Actual and setpoint inlet temperatures.

Initial temperature Starting temperature for the inlet.

Initial time Hold time at the inlet initial temperature.

Rate # Temperature program rates for inlet thermal ramps.

Final temp # Final inlet temperature for ramps 1, 2, and 3.

Final time # Hold time at Final temp 1, 2, and 3.

Pressure Actual and setpoint inlet pressure. Controls capillary column flow and linear velocity.

Split ratio The ratio of split flow to column flow. Column flow is set in the column parameter list. This line does not appear if a column in the flow path is not defined.

Split flow Flow, in mL/min, from the split/purge vent. This line does not appear if a column in the flow path is not defined.

Total flow These are the actual and setpoint values of the total flow into the inlet, which is the sum of the split flow, column flow, and septum purge flow. When you change the total flow, the split ratio and split flow change while the column flow and pressure remain the same.

Septum Purge Flow through the septum purge vent.

Gas saver On to reduce split vent flow at **Saver time**.

Saver flow Reduced split vent flow, at least 15 mL/min.

Saver time Time when flow is reduced to save gas.

If all columns in the flow path are defined

- 1 Press [**Front Inlet**].
- 2 Scroll to **Mode:** and press [**Mode/Type**]. Select **Split** or **Pulsed split**.
- 3 Set the inlet temperature (**Initial temperature**) and any desired ramps.
- 4 If you want a specific split ratio, scroll to **Split ratio** and enter that number. The split flow will be calculated and set for you.
- 5 If you want a specific split flow, scroll to **Split flow** and enter that number. The split ratio will be calculated and displayed for you.
- 6 If you selected **Pulsed split**, enter values for **Pulsed pressure** (pressure at injection) and **Pulse time** (minutes after injection to return to normal pressure).
- 7 If desired, turn on **Gas saver**. Set the **Saver time** after the injection time.
- 8 Press [**Prep Run**] before manually injecting the sample if the Gas Saver is on (see [“Pre Run and Prep Run”](#) on page 171).

If a column in the flow path is not defined

- 1 Press [**Front Inlet**].
- 2 Set the inlet temperature (**Initial temperature**) and any desired ramps.
- 3 Set other parameters as described for a defined column.
- 4 Set **Total flow** into the inlet. Measure flows out of the split vent and septum purge vent using a flow meter.
- 5 Subtract the septum purge flow and split vent flow from **Total flow** to get column flow.

- 6 Calculate the split ratio (split vent flow/column flow). Adjust as needed

PTV inlet splitless and pulsed splitless modes

In these modes—with or without a pressure pulse—the split vent valve is closed during injection and vaporization of the sample and stays so while the sample transfers to the column.

At a specified time after injection, the valve opens to sweep vapors left in the liner out the split vent. This avoids solvent tailing due to the large inlet volume and small column flow rate.

The figures show the flows with the septum head. Flows with the septumless head are the same except that the septum purge flow bypasses the head.

Stage 1. Sample injection

With the split vent valve closed, the sample and solvent transfer to the column.

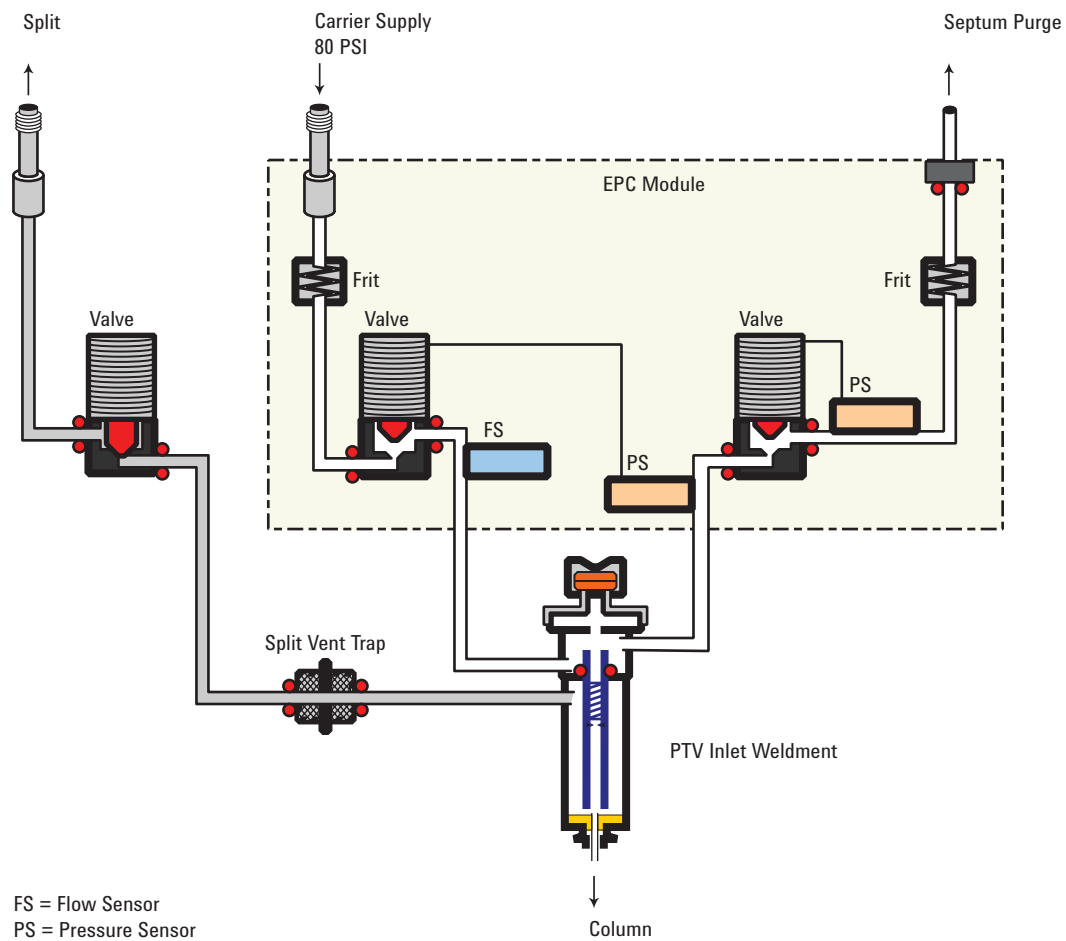

Stage 2. Solvent purging

After the sample has transferred to the column, the split vent valve opens to purge remaining solvent vapor from the inlet.

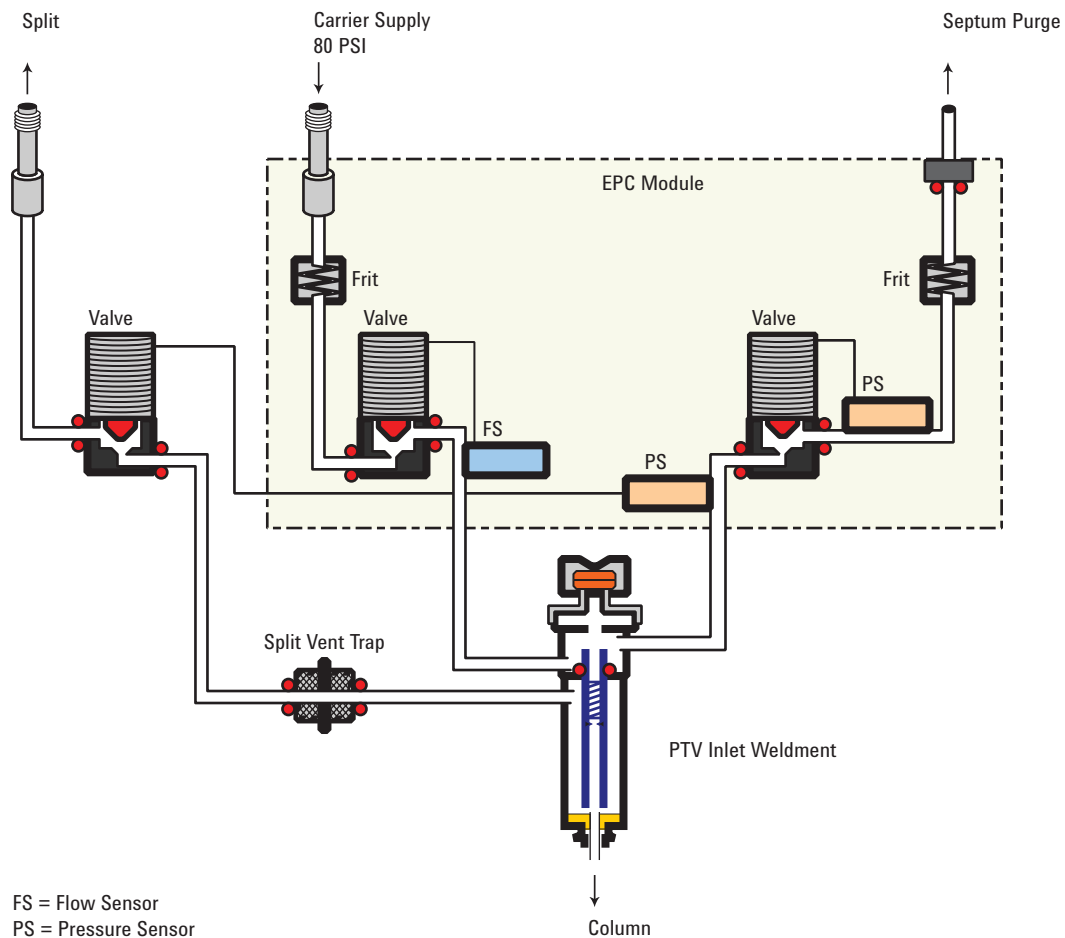

Timelines

This figure summarizes the flow, pressure, and temperature changes during a splitless mode analysis.

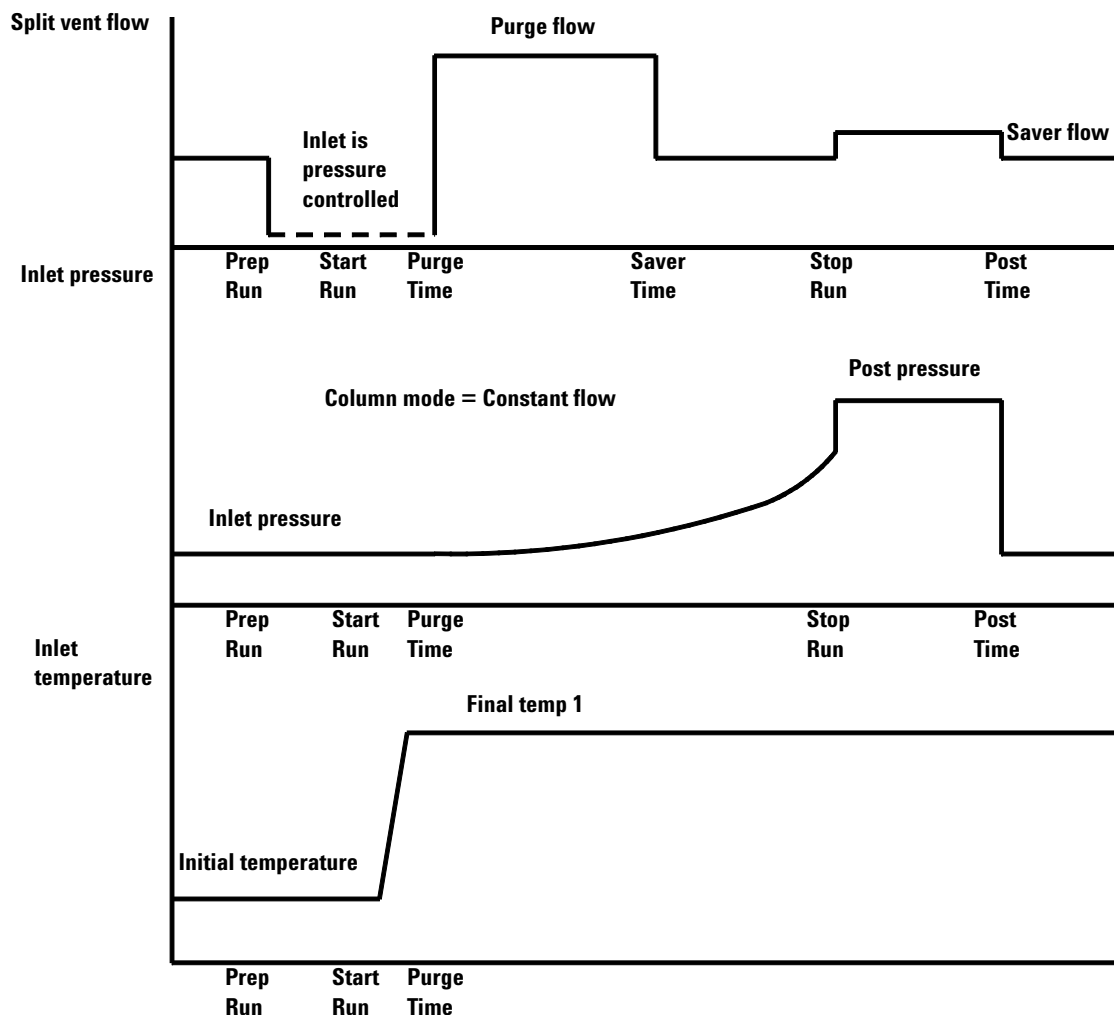

Cold splitless introduction

For cold splitless introduction, use an initial inlet temperature below the normal boiling point of the solvent. For most solvents, starting the first inlet temperature ramp at 0.1 minutes provides good transfer and reproducibility. A program rate of 500 °C/min or higher is appropriate for thermally stable analytes. A final temperature of 350 °C, held for 5 minutes, has quantitatively transferred up to C₄₄ alkane.

A main advantage of temperature programmability is that the inlet can be heated gently to transfer delicate analytes. If the oven temperature is initially low enough to refocus the analytes on the column, the inlet heating rate can be made slower (e.g., 120 °C/min). This reduces thermal degradation from the inlet and can improve peak shape and quantitation.

For most applications of cold splitless, a single temperature ramp is enough. The remaining ramps can be used to clean the liner or to decrease the inlet temperature to prepare for the next injection.

Hot splitless introduction

For hot splitless introduction, select an initial temperature high enough to volatilize the analytes. No additional temperature parameters are required as the inlet will maintain the setpoint throughout the run.

Because of the small liner volume (about 120 μL), the PTV cannot contain vapor resulting from large liquid injection volumes. Injection volumes greater than 1 μL may overflow vapor from the inlet, causing analysis variations. Cold splitless introduction avoids this problem.

Starting values

A successful splitless injection consists of these steps:

- 1 Inject the sample and temperature program the inlet to vaporize it.
- 2 Use a low column flow and low oven temperature to create a solvent-saturated zone at the head of the column.
- 3 Use this zone to trap and reconcentrate the sample at the head of the column.
- 4 Wait until all, or at least most, of the sample has transferred to the column. Then discard the remaining vapor in the inlet—which is mostly solvent—by opening a purge valve. This eliminates the long solvent tail that this vapor would otherwise cause.
- 5 Raise the oven temperature to analyze the sample.

Some experimentation is needed to refine the operating conditions. [Table 43](#) provides starting values for the critical parameters.

Table 43 Splitless mode inlet parameters

Parameter	Allowed setpoint range	Suggested starting value
Oven temperature	No cryo, ambient+10 °C to 450 °C CO ₂ cryo, -60 °C to 450 °C N ₂ cryo, -80 °C to 450 °C	10 °C below solvent boiling point
Oven initial time	0 to 999.9 minutes	≥ Inlet purge time

Table 43 Splitless mode inlet parameters (continued)

Parameter	Allowed setpoint range	Suggested starting value
Inlet purge time	0 to 999.9 minutes	$\frac{2 \times \text{Liner volume}}{\text{Column flow}}$
Gas saver time	0 to 999.9 minutes	After purge time
Gas saver flow	15 to 1000 mL/min	15 mL/min greater than maximum column flow
Inlet temperature	No cryo, oven temp + 10 °C CO ₂ cryo, -50 °C to 450 °C N ₂ cryo, -60 °C to 450 °C	10 °C below solvent boiling point for 0.1min, then ramp up

Setting parameters for the splitless modes

Mode: The current operating mode—Splitless or Pulsed splitless.

Temperature Actual and setpoint inlet temperatures.

Initial time Hold time at the initial inlet temperature.

Rate # Temperature program rates for inlet thermal ramps.

Final temp # Final inlet temperature for ramps 1, 2, and 3.

Final time # Hold time at Final temp 1, 2, and 3.

Pressure Actual and setpoint inlet pressure in psi, bar, or kPa

Pulsed pres The inlet pressure you desire at the beginning of a run. The pressure rises to this setpoint after [**Prep Run**] is pressed and remains constant until **Pulse time** elapses, when it returns to **Pressure**.

Pulse time Pressure returns to its normal setpoint at this time.

Purge time The time, after the beginning of the run, when you want the split vent valve to open.

Purge flow The flow, in mL/min, from the split vent, at **Purge time**. You will not be able to specify this value if operating with your *column not defined*.

Total flow The Total flow line displays the actual flow to the inlet during a Pre- run (Pre- run light is on and *not* blinking) and during a run before purge time. You cannot enter a setpoint at these times. At all other times, Total flow will have both setpoint and actual values.

Septum purge Flow through the septum purge vent

Gas saver On to reduce split vent flow at **Saver time**

Server flow Reduced split vent flow, at least 15 mL/min

Server time Time when flow is reduced to save gas

If the column is defined

- 1 Press [**Front Inlet**].
- 2 Scroll to **Mode:** and press [**Mode/Type**]. Select **Splitless** or **Pulsed splitless**.
- 3 Set the inlet temperature and any desired ramps.
- 4 Enter a **Purge time** and a **Purge flow**.
- 5 If desired, turn **Gas saver** on. Make certain the time is set after the **Purge time**.
- 6 Press [**Prep Run**] (see “[Pre Run and Prep Run](#)” on page 171) before manually injecting a sample. This is automatic if an Agilent sampler is used.

If the column is not defined

- 1 Press [**Front Inlet**].
- 2 Scroll to **Mode:** and press [**Mode/Type**]. Select **Splitless** or **Pulsed splitless**.
- 3 Set the inlet temperature and any desired ramps.
- 4 Enter a **Purge flow**.
- 5 Enter the **Purge time** when you wish the split valve to open.
- 6 Set **Total flow** greater than the column flow plus the septum purge flow to guarantee adequate column flow.
- 7 Turn **Gas saver** on, if desired. Set the time after **Purge time**.
- 8 Press [**Prep Run**] (see “[Pre Run and Prep Run](#)” on page 171) before manually injecting a sample. This is automatic if an Agilent sampler is used.

PTV inlet solvent vent mode

This mode is typically used for large volume injections. For single injection use a 50 or 100 μL syringe with variable plunger speed—slowly, 5 to 30 seconds.

The sample is injected into a cold inlet. If conditions are properly chosen and the sample is suitable, analytes deposit in the inlet liner while the solvent evaporates and is swept out. Large or multiple injections can be used to concentrate sample in the inlet before transferring to the column for analysis.

The figure shows the flows with the septum head. Flows with the septumless head are the same except that the septum purge flow bypasses the head.

Stage 1. Sample and vent

During sampling and venting, the split valve is open. The inlet is at **Initial temperature**, which is at or below the solvent boiling point.

Solvent vapors are swept out the vent, while sample deposits on the liner walls or packing.

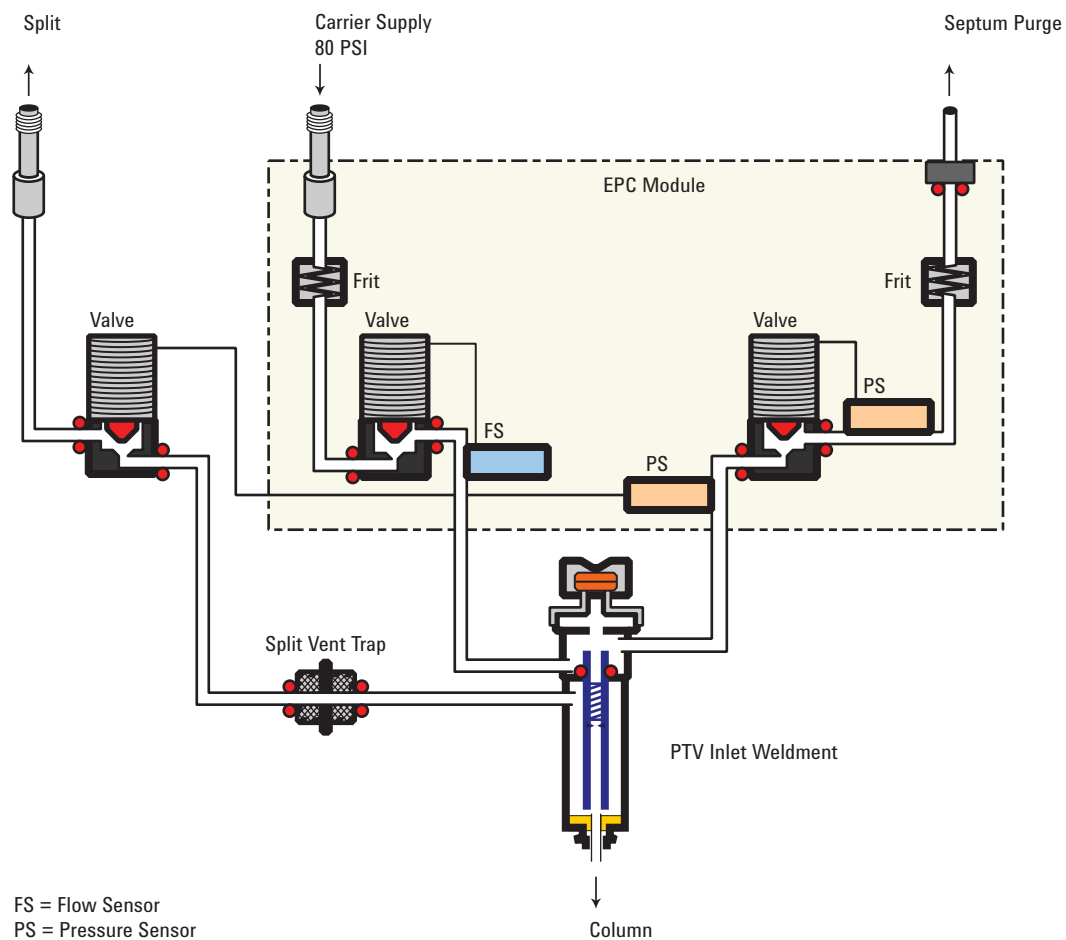

Stage 2. Sample transfer

When solvent venting ends, the split valve vent closes and the inlet heats to **Final temperature 1**. The sample transfers to the capillary column during **Purge delay time**.

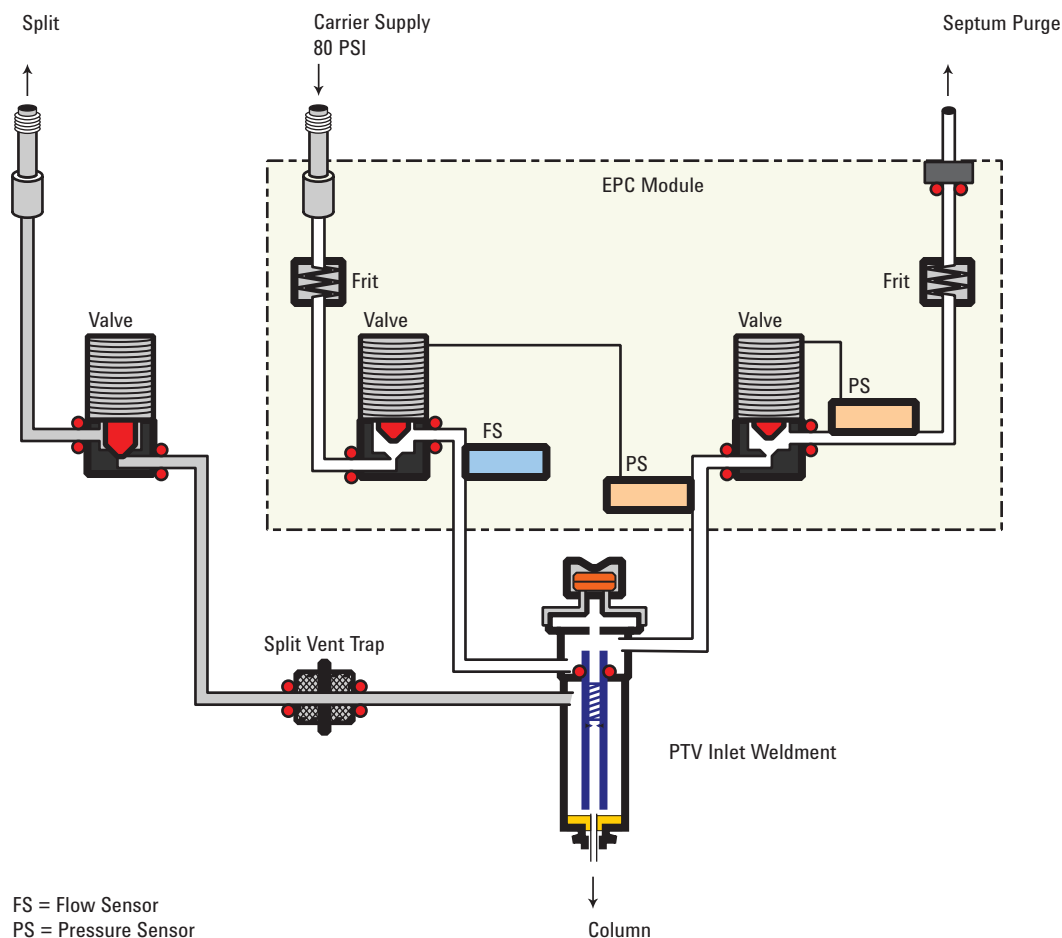

Stage 3. Purge and cleanup

The split valve opens again and the system returns to the Stage 1 configuration but with different setpoints. The PTV inlet is flushed. Additional ramp rates are available to thermally clean the inlet or to reduce inlet temperature after sample transfer. This can extend the life of the liner.

Temperature, pressure, and flow considerations

The solvent vent mode goes through three distinct pneumatic states; venting, sample transfer, and purging. The vent portion allows the inlet pressure and the vent flow to be adjusted to optimize solvent elimination. The transfer state mimics traditional splitless operation and transports the analytes from the liner to the column. The purging mode allows the user to prepare the inlet for the next run.

A fundamental difficulty with solvent vent mode is the potential loss of volatile analytes with the solvent. Several solutions are possible for this situation:

- The inlet liner can be packed with a more retentive material, such as Tenax. This greatly improves volatile analyte recovery but may impact recovery of higher boiling materials.
- Some of the solvent can be left in the liner when sample transfer begins. The residual solvent acts like a stationary phase and retains volatile material, but at the expense of a larger solvent peak.
- The inlet temperature can be reduced. This reduces the vapor pressure of the volatile analytes and permits higher recoveries.

Solvent removal can be speeded up by:

- Reducing pressure in the inlet during sample introduction—the **Vent pressure** parameter
- Increasing flow through the inlet—the **Vent flow** parameter

While all these possibilities do complicate use of the PTV, they provide increased flexibility and new potential to solve difficult problems.

Sequence of operations

These are the steps in a typical analysis using the solvent vent mode:

Table 44 The solvent vent process

Step	Parameter	Value
1	Before injection	
	Flow at split vent	Either Purge flow or Saver flow
	Inlet pressure	Derived from column setpoint
The system is resting, with Purge flow (or Saver flow, if on) through the inlet.		
2	Prep Run begins	
	Flow at split vent	Vent flow setpoint
	Inlet pressure	Vent pressure setpoint
Setpoints change to prepare for injection. When GC is ready, the sample is injected. Inlet and oven temperature program Init times begin. Solvent venting and analyte trapping begin.		
3	At Vent end time	
	Flow at split vent	None, split valve closed
	Inlet pressure	Column pressure setpoint
Solvent venting ends, analyte transfer begins as inlet heats up.		
4	At Purge time	Purge flow setpoint

Table 44 The solvent vent process (continued)

Step	Parameter	Value
	Inlet pressure	Column pressure setpoint
Analyte transfer ends, inlet is purged of residual vapor. Analysis begins.		
5	At Saver time	
	Flow at split vent	Saver flow setpoint
	Inlet pressure	Column pressure setpoint
Analysis ends, carrier flow reduced to save gas (if Saver is on).		

Some important points

- The flow through the column is governed by the pressure in the inlet. This is controlled, during the analysis part of the process, by the flow or pressure setpoint or program entered *for the column*.
- The controlling times must be in the order shown; Vent end time *before* Purge time and PTV temperature **Initial time** *before* Saver time.
- Vent end time must occur before the inlet starts to heat and release analytes.
- Purge time must occur before the oven begins to heat and move sample through the column.

Timelines

Time increases downward; all other quantities increase to the right.

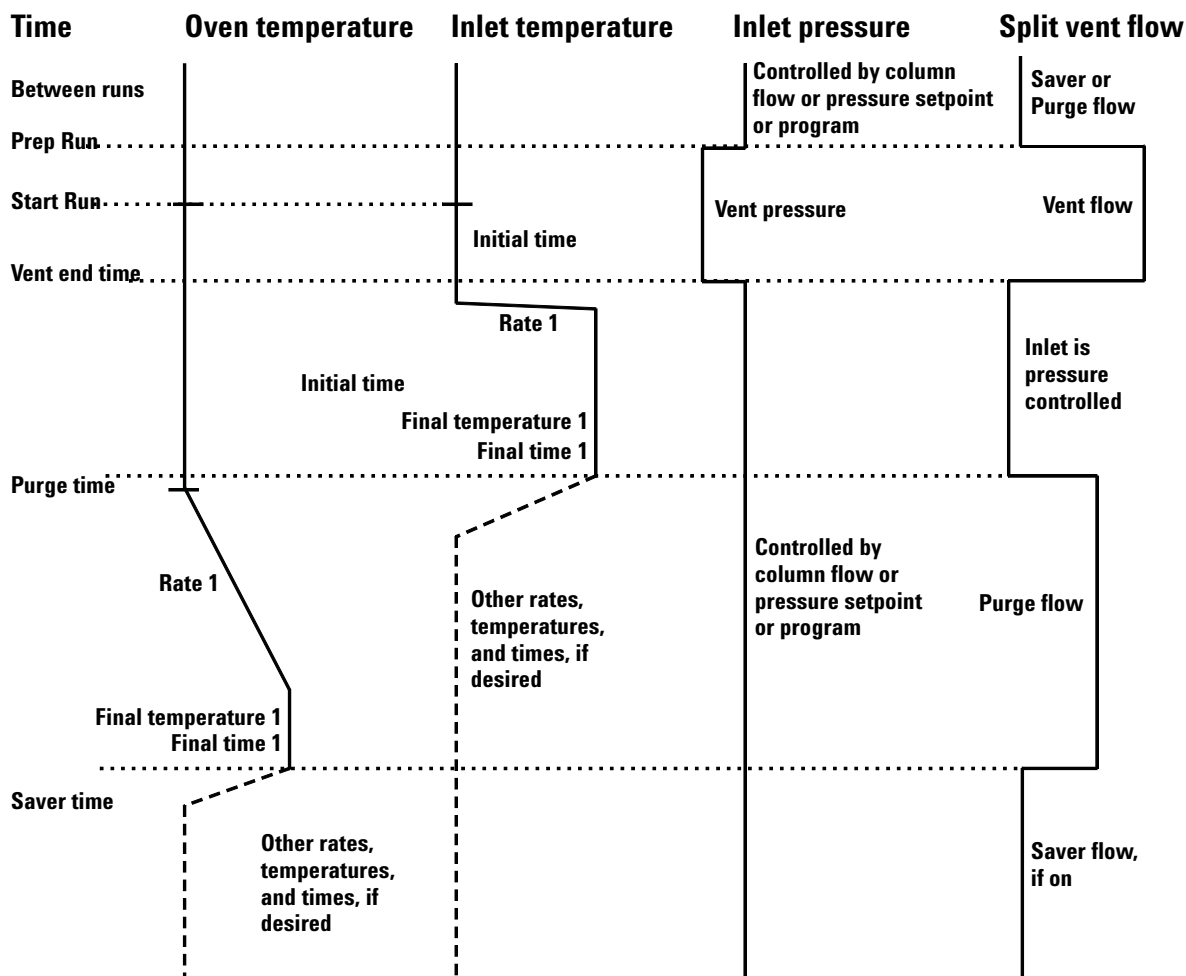

When is Start Run?

Both the inlet and oven temperature programs begin at Start Run. All times—such as Purge time—are measured from Start Run. When does Start Run occur?

- If the sample is injected manually, Start Run occurs when the user presses the **[Start]** key.
- If a single injection per run is made using an autosampler, Start Run occurs when the syringe carrier moves down to make the injection.
- If multiple injections per run are made using an autosampler, Start Run occurs when the syringe carrier moves down to make the first injection of the set. There are no Start Run signals for the rest of the injections in the set.

These additional injections take time. The inlet and oven temperature programs, mainly the **Initial time** values, must be adjusted to allow for this. So must the various time values that

control the inlet operation. This is discussed in more detail under [“To develop a PTV method that uses large volume injection”](#) on page 247.

Setting parameters for solvent vent operation

Mode: The current operating mode—solvent vent.

Temperature Actual and setpoint initial inlet temperatures.

Initial time The time, measured from Start Run, when the initial inlet temperature hold ends. Must be greater than **Vent end time**.

Rate # Temperature program rate for inlet thermal ramps.

Final temperature # Final inlet temperature for ramps 1, 2, and 3.

Final time # Hold time at **Final temp #**. This time is a duration; it is *not* measured from Start Run.

Pressure Actual and setpoint inlet pressure before and after the vent period. It sets the starting point of column head pressure.

Vent pressure The inlet pressure during the vent period. By decreasing the inlet pressure while venting, solvent elimination proceeds faster. Also, the pressure reduction decreases the amount of carrier gas—and solvent vapor—that enters the column during this time.

Users select from 0 to 100 psig. If 0 is chosen, the inlet uses the lowest pressure possible at the given vent flow. [Table 45](#) shows approximate values for this minimum at various vent flows of helium. Pressures less than those in the table are not possible unless the flow is reduced.

Table 45 Minimum attainable pressures

Vent flow (mL/min)	Actual vent pressure at “0” psig setpoint	Actual vent pressure at “0” kPa setpoint
50	0.7	5
100	1.3	10
200	2.6	18
500	6.4	44

Table 45 Minimum attainable pressures

Vent flow (mL/min)	Actual vent pressure at "0" psig setpoint	Actual vent pressure at "0" kPa setpoint
1000	12.7	88

Vent flow The flow of carrier gas out the split vent during the vent period. Higher flows sweep the liner more quickly and reduce the time for solvent elimination. For most columns, 100 mL/min vent flow eliminates solvent at an acceptable rate but puts minimal material on the column.

Vent end time The time, measured from Start Run, when solvent venting ends. For large volume injections, this time is normally greater than the time for the injection to complete.

Purge time The time, measured from Start Run, when sample transfer ends. It began at **Vent end time**.

Purge flow The flow of carrier gas to the inlet beginning at **Purge time**.

Total flow The actual flow into the inlet.

Septum Purge Flow through the septum purge vent

Gas saver On to reduce split vent flow at **Saver time**

Saver flow Reduced split vent flow, at least 15 mL/min

Saver time Time when flow is reduced to save gas

If the column is defined

- 1 Press [**Front Inlet**].
- 2 Scroll to **Mode:** and press [**Mode/Type**]. Select **Solvent vent**.
- 3 Enter a **Vent pressure**, a **Vent flow**, and a **Vent end time**.
- 4 Set the inlet temperature and ramps, as desired.
- 5 Enter a **Purge time** and a **Purge flow**.
- 6 If desired, turn **Gas saver** on. Make certain the time is set after the **Purge time**.
- 7 Press [**Prep Run**] (see "[Pre Run and Prep Run](#)" on page 171) before manually injecting a sample.

If the column is not defined

- 1 Set up the parameters as described for the defined column case.
- 2 Set **Total flow** greater than the column flow plus the septum purge flow to guarantee adequate column flow.

To develop a PTV method that uses large volume injection

This topic provides a recommended way to change from a splitless injection using a split/splitless inlet to a solvent vent mode injection using a programmable temperature vaporization inlet (PTV). It applies mainly to large volume injections (LVI) using a PTV, but the concepts can apply to general PTV use. This topic does not consider all items that can impact an analysis, for example the liner, solvent, analyte boiling points, or polarity. This topic also assumes knowledge of your data system—when to save a method, how to start a run, how to set up a single run, etc.

The main advantage of the PTV inlet's solvent vent mode is that you can inject slowly into the inlet, allowing large amounts of solvent to evaporate in the liner (not in the split vent line). This concentrates the analytes prior to injection. It requires an injector with variable speed injections, a “large” syringe, and knowledge of the sample and the solvent.

When developing a solvent vent method, the goal is to determine the injection rates and temperatures needed to evaporate the solvent at the rate it enters the inlet. The development technique is to gradually scale up to an injection amount that produces a useful response. The most significant parameters are:

Temperature Hold the inlet temperature at or slightly below the solvent boiling point until after all the sample has been injected. This is important so that you do not boil away more volatile analytes, or boil away the solvent in the needle and trap your analytes there. An additional point to consider is that the boiling point of the earliest eluting analyte should be 100 °C less than the boiling point of the solvent.

Injection speed Estimate the evaporation rate of solvent exiting the needle based on solvent type, inlet temperature, vent flow, and pressure. Start with about half that number. Note that you have to make sure that you configure the syringe properly. If not, you will over- or under- load the inlet.

Vent end time The vent end time setpoint must be greater than the time the needle spends in the inlet. If the vent time is too short, you will overload and contaminate the column and inlet. Adjust the vent time as you scale up the method.

If using a PTV with an MSD, another tip for method development is to scan for solvent ions. Detecting the solvent ions can be useful in troubleshooting residual solvent bleed onto the column.

To develop a PTV method for large volume injection, try the following:

- 1 Determine a small injection volume that works on a split/splitless inlet in splitless mode or the PTV in splitless mode. Choose a volume that does not currently overload the inlet.
- 2 Start with a 5–10 uL syringe and make sure the syringe is properly configured in the instrument and data system.
- 3 Make sure the column is configured.
- 4 Set up the inlet to perform a 1 uL injection.

Use the splitless method conditions, except:

- Start with the inlet temperature cold, near but slightly below the solvent boiling point. For example, if using methylene chloride (boiling point 39 °C), start with a temperature of 30–39 °C.
 - Use **Splitless** mode.
 - Ramp to the normal splitless inlet temperature.
- 5 Note the response achieved.
 - 6 Next, change the inlet mode to **Solvent vent**.
 - 7 Check the injector timings.
 - a Install an empty sample vial in the injector turret or tray.
 - b Input the injection rate (**Sample Draw Speed**, **Sample Disp Speed**, and **Inject Dispense Speed** rates) for the injector and increase the injection volume to 5 uL.
 - c Enter draft Solvent vent parameters:
 - Set a **Vent flow** of 100 mL/min as a starting point.
 - Keep the inlet isothermal for now.

- Enter a **Vent pressure** of 0 psi (0 kPa) and **Vent end time** of 0.1 minutes.
- d Make an injection using the empty vial. Use a stopwatch or your GC's timer feature to time how long the needle is in the inlet.
- 8 Enter revised **Solvent vent** mode parameters.
- Set the method's **Vent end time** to be about 0.05 min longer than the time the needle spends in the inlet.
 - Set the inlet temperature **Initial time** to be about 0.05 min longer than the **Vent pressure time**.
 - Program the inlet to ramp quickly to the injection temperature. Make sure the ramp starts after the **Vent end time**.
 - Set the **Purge Flow** to 30 mL/min. Set the purge time to be the vent pressure **Vent end time** + 1 minute.
- 9 Make a 5 uL injection of your standard. You should see 5 times the response.

If the response of **all analytes** is too low:

- The dispense speed is too fast. Liquid was injected into the inlet and pushed out the vent.
- The vent time is too long. The inlet started to heat while the vent was open.

If the response of **early eluters** is too low:

- The inlet temperature is too high.
- The **Vent flow** is too high.

If the response of **late eluters** is too low:

- The purge time is too short.
- The final inlet temperature is too low.

- 10 If you need more injection volume and the 5 uL worked to give 5 times the response, change the syringe to a larger one, for example, 50 uL.
- 11 Set up the data system to perform a 25 uL injection.
- 12 Configure the syringe. Make sure the plunger speeds on the injector are still set properly.
- 13 Recheck the injector timings. See the step above.
- 14 Set a new vent time and initial inlet temperature time based on the new time the needle spends in the syringe.
- 15 Make a 25 uL injection of your standard. Again, you should see 5 times the response. If not, see step 13.

- 16 If you need more response, repeat steps 10 through 15 to increase to larger volume. See the next section. Try performing 5 x 5 uL injections, then 5 x 50 uL injections.

Multiple injections with the PTV inlet

The preferred technique for concentrating analytes in the inlet liner is to use a single, large volume injection. Using a high capacity syringe and one septum puncture reduces the possibility of contamination and generally improves results when compared against a multiple septum puncture technique. However, if needed, you can perform multiple septum punctures during the vent time. This technique requires an Agilent data system and automatic liquid sampler.

Data system requirements

An Agilent data system is necessary for multiple injection because the needed parameters are not available through the GC keyboard.

GC ChemStation Software revision B.04.01 SP1 or later.

MSD ChemStation Software revision E.02.00 SP2 or later

EZChrom Software revision 3.3.2 or later

Setting parameters for the inlet in solvent vent mode

Set or configure the following parameters in the data system's 7890A GC method editor.

Syringe size – Verify the syringe size is configured correctly. The configured syringe size changes the available choices for injection volume.

Injection volume – Select the injection volume, then enter a number of injections. The total injection volume will be displayed.

Multiple Injection Delay – A pause time, in seconds, between injections. This is added to the minimum hardware cycle time.

Preinjection washes and pumps are performed only before the first injection of a multiple injection set.

Postinjection washes are performed only after the last injection in a multiple injection set.

An example

These values were used for a sample with a broad range of boiling points.

Table 46 General parameters

Name	Value
Sample	C ₁₀ to C ₄₄ hydrocarbons in hexane
Mode	Solvent vent
MMI liner	Glass wool packed
Injection volume	One 10.0 µL injection (25 µL syringe)
Injection speed	Fast
Column	30 m x 320 µm x 0.25 µm -5, part number 19091J-413
Column flow	4 mL/min constant flow

Table 47 Inlet parameters

Name	Value	Name	Value
Initial temp	40 °C	Rate 2 (off)	
Initial time	0.3 min	Pressure	15.6 psig
Rate 1	720 °C/min	Vent pressure	0.0 psig
Final temp 1	450 °C	Vent flow	100 mL/min
Final time 1	5 min	Vent end time	0.2 min
Rate 2	100 °C/min	Purge time	2.0 min
Final temp 2	250 °C	Purge flow	50 mL/min
Final time 2	0 min		

Table 48 Oven parameters

Name	Value
Initial temp	40 °C
Initial time	2.5 min
Rate 1	25 °C/min
Final temp 1	320 °C
Final time 1	10.0 min

Table 48 Oven parameters

Name	Value
Rate 2 (off)	

Table 49 Detector parameters

Name	Value
Detector	FID
Detector temp	400 °C
Hydrogen flow	40 mL/min
Air flow	450 mL/min
Makeup (N ₂)	45 mL/min

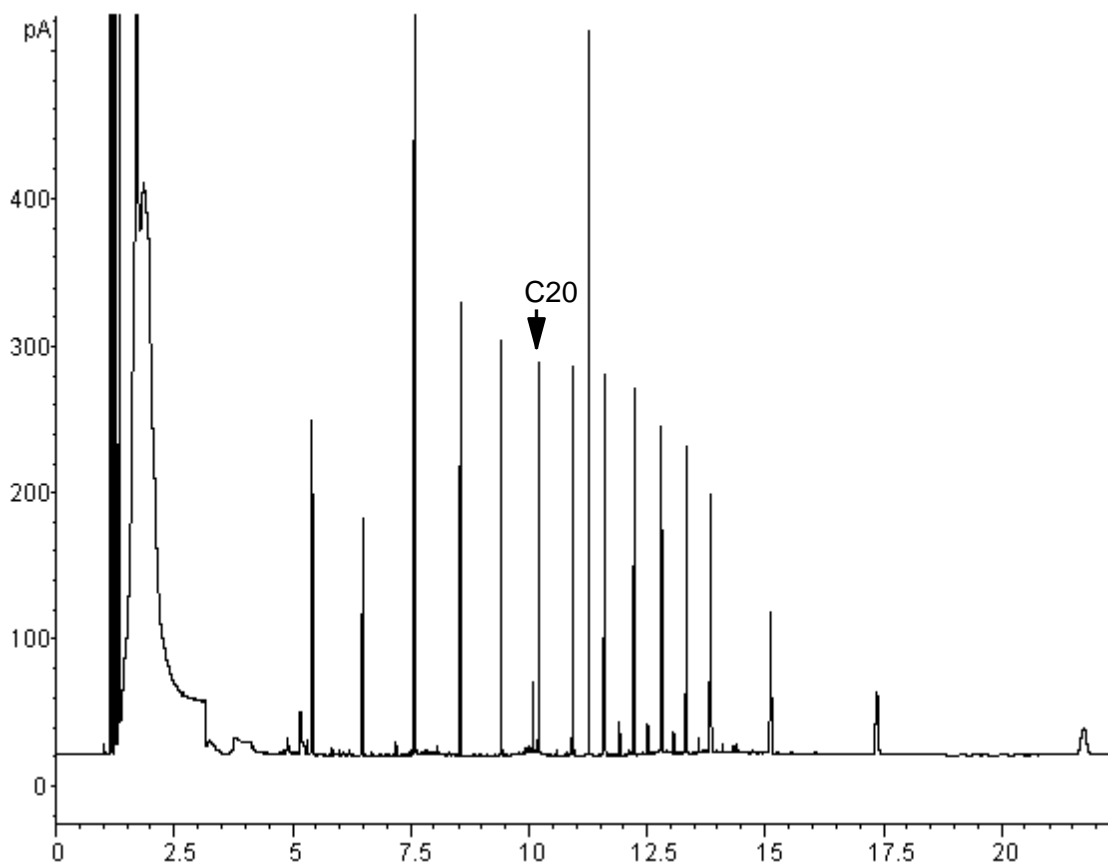

These results were compared with a splitless analysis of the same sample, which should produce 100% recovery of all analytes. The data showed that, under these conditions,

compounds above C₂₀ were completely recovered and that the recovery was independent of injection size. Compounds lower than C₂₀ were partially vented with the solvent.

Possible adjustments

Depending on what you are trying to accomplish, you have a number of possible adjustments available.

To eliminate more solvent

- Increase the vent end time, inlet initial time, and purge time. This will not affect analytes that are quantitatively trapped but will eliminate more of the solvent peak.
- Increase the vent flow to sweep the liner more rapidly with the same inlet timing. Increasing vent flow raises vent pressure if it is set to 0. This puts more solvent onto the column.
- Raise the inlet initial temperature to vaporize more solvent and allow more to be eliminated. This also increases the loss of volatile analytes since their vapor pressures also increase.

To improve recovery of low boiling analytes

- Reduce inlet temperature to lower the vapor pressure of the analytes and trap them more effectively. This also reduces solvent vapor pressure and more time will be needed to eliminate it.
- Use a retentive packing in the liner. Materials such as Tenax permit higher recovery of volatile analytes but may not release higher boiling compounds. This must be considered if quantitation on these high boiling peaks is desired.
- Leave more solvent in the liner. The solvent acts as a pseudo stationary phase and helps retain volatile analytes. This must be balanced against the detector's tolerance for solvent.

An example—continued

The single injection example shown on the last few pages makes it clear that a 10 µL injection does not overload the glass wool packed liner. This means that multiple 10 µL injections are possible.

It was decided to make 10 injections per run, each of 10 µL size. This would increase analytical sensitivity substantially. No adjustments were made to improve recovery of the low boilers since the purpose of this analysis was to detect and measure the high boiling components.

After timing a trial set of 10 injections, the total time for the multiple injection set was measured to be approximately 1.3 minutes. The following timing changes were made:

Table 50 Modifications

Parameter	Increased from	To
Inlet Init time	0.3 minutes	1.6 minutes
Vent end time	0.2 minutes	1.5 minutes
Purge time	2.0 minutes	3.0 minutes
Oven Init time	2.5 minutes	3.0 minutes

The result is shown in the next figure. Note the difference in the vertical scale (5000 versus 500).

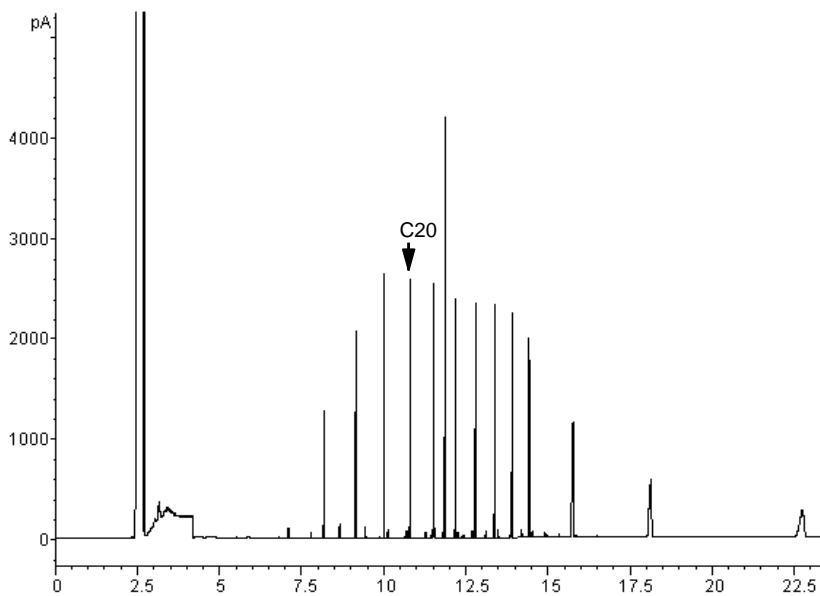

About the Volatiles Interface

The volatiles interface provides a simple, reliable way to introduce a gas sample into your GC from an external device such as a headspace, purge and trap, or air toxic sampler. Manual syringe injections cannot be made with this interface. The interface has a small volume and is highly inert, ensuring high sensitivity and resolution for applications requiring trace level detection.

The figure shows the pneumatics in the split mode.

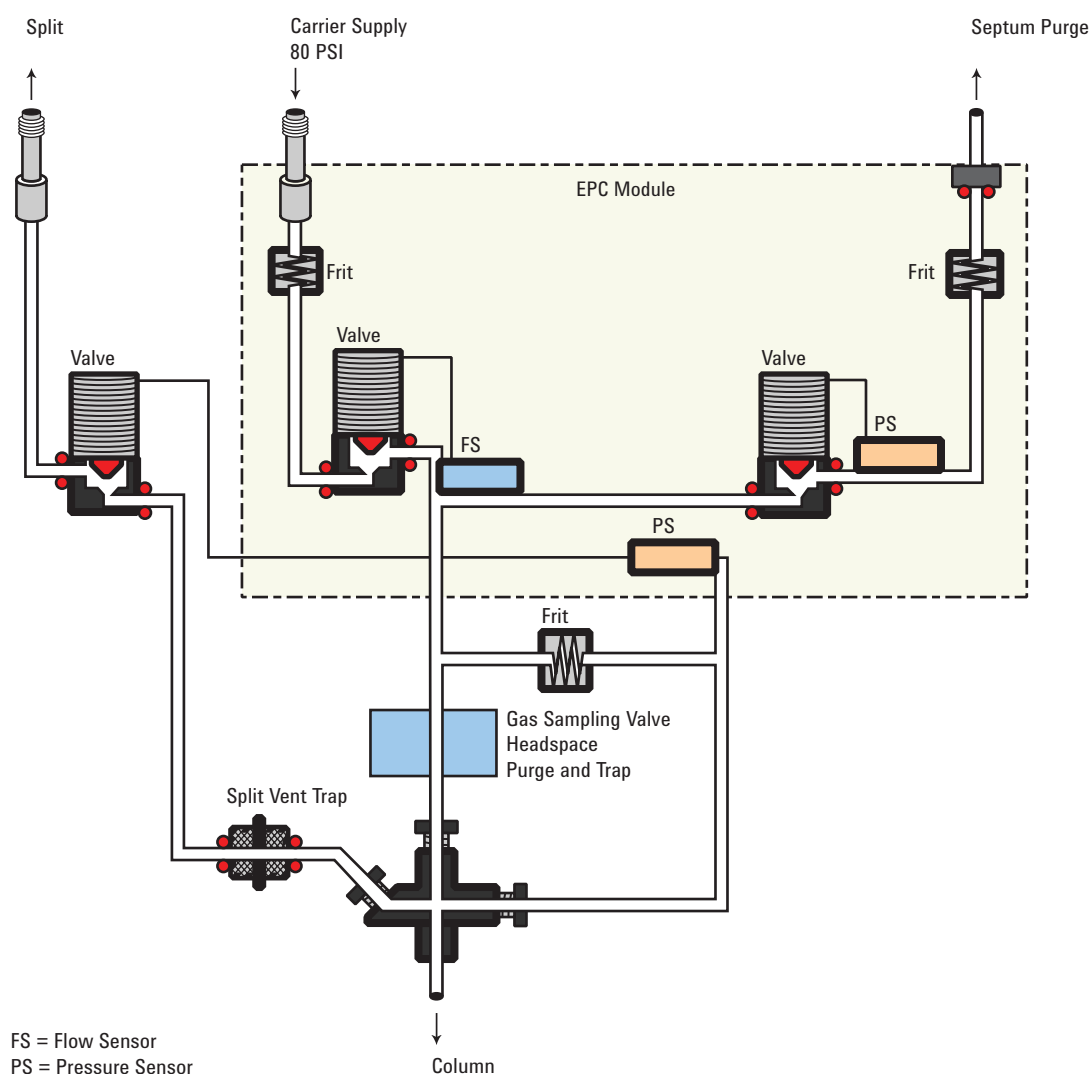

Total flow to the interface is measured by a flow sensor and is divided into two streams. One stream connects to the septum purge regulator; the other connects to a frit block. At the frit block, the flow is further divided. The first stream goes to the

gas-phase sampler and from there is introduced into the interface. The second stream, called the pressure sensing line, passes through the frit block and is measured by a pressure sensor. This stream also provides a trickle flow to the interface.

VI operating modes

There are three modes of operation—split, splitless, and direct. The pneumatics differ for each operating mode and are discussed in detail in the rest of this document.

[Table 51](#) summarize some issues to consider when choosing an operating mode. Specifications for the interface are also listed.

Table 51 Overview of the volatiles interface

Mode	Sample concentration	Sample to column	Comments
Split	High	Very little, most is vented	
Splitless	Low	All	Can switch to split mode electronically.
Direct	Low	All	Must physically disconnect split vent, plug the interface, and reconfigure the GC. Maximizes sample recovery and eliminates possibility of contamination to pneumatic system.

Table 52 Specifications of the volatiles interface

Specification	Value/Comment
Deactivated flow path	
Volume	32 μ L
Internal dimensions	2 mm by 10 mm
Maximum flow to interface	100 mL/min
Split range	Depends on column flow Typically no split to 100:1
Temperature range	10 °C above ambient (with oven at ambient) to 400 °C

Table 52 Specifications of the volatiles interface (continued)

Specification	Value/Comment
Recommended temperature:	≥ transfer line temperature of the external sampling device

About the VI split mode

When you introduce a sample in the split mode, a small amount of the sample enters the column while the major portion exits from the split vent. The ratio of split flow to column flow is controlled by the user. The split mode is primarily used for high concentration samples when you can afford to lose most of the sample out the split vent and for samples that cannot be diluted.

Split ratio

Because of the interface's small internal volume, the maximum total flow to the interface is 100 mL/min. This maximum flow puts some restriction on the split ratio you can set.

Table 53 Maximum split ratios

Column diameter (mm)	Column flow (mL/min)	Maximum split ratio	Total flow (mL/min)
0.20	1	100:1	100
0.53	5	20:1	100

Split mode pneumatics

During Pre Run, during sampling, and after sampling, total flow to the interface is measured by a flow sensor and controlled by a proportional valve. Flow at the head of the column is back-pressure regulated. Pressure is sensed upstream from the proportional valve.

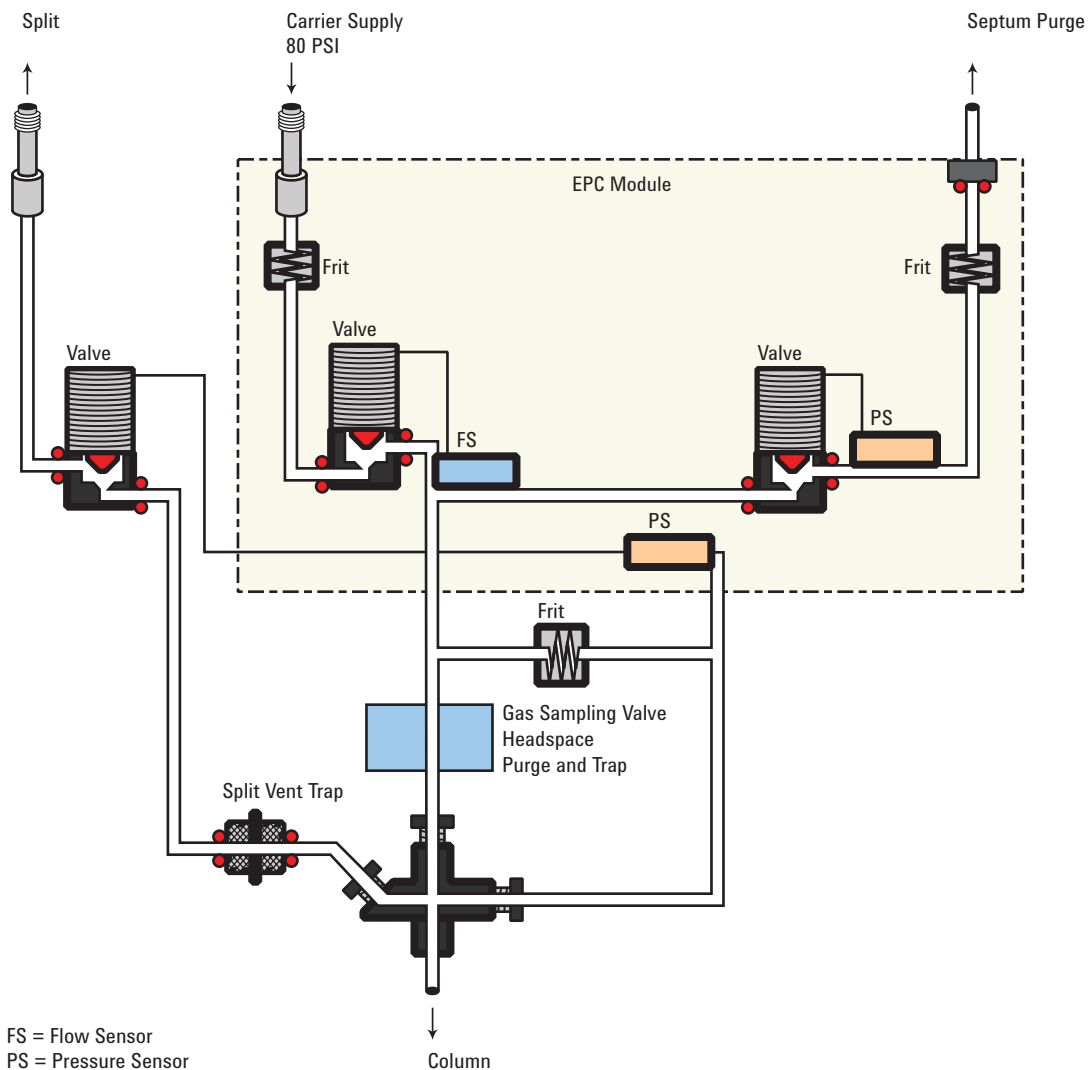

Setpoint dependencies

Some setpoints are interdependent. If you change one setpoint, other setpoints may change to compensate. With a defined capillary column, setting column flow or linear velocity will set the inlet pressure.

Table 54 Setpoint dependencies

When you change	These setpoints change	
	Column defined	Column not defined
Pressure	Column flow* Split flow Total flow	No changes

Table 54 Setpoint dependencies (continued)

When you change	These setpoints change	
	Column defined	Column not defined
Column flow [*]	Pressure Split flow Total flow	not available
Split flow	Split ratio Total flow	not available
Split ratio	Split flow Total flow	not available
Total flow	Split flow Split ratio	No changes

* This setpoint appears in [Col 1] or [Col 2].

Initial values

Use the information in [Table 55](#) to help you set up the operating conditions for your interface.

Table 55 Suggested starting values

Parameter	Allowed setpoint range	Suggested starting value
Oven initial time	0 to 999.9 minutes	After sample on column
Interface temperature	Ambient + 10 °C to 400 °C	≥ Transfer line temperature
Gas saver time	0 to 999.9 minutes	After sample on column
Gas saver flow	15 to 100 mL/min	15 mL/min greater than maximum column flow

Setting parameters for the split mode

Mode: The current operating mode—split

Temperature Actual and setpoint interface temperatures

Pressure Actual and setpoint interface pressure. Controls capillary column flow.

Split ratio The ratio of split flow to column flow. Column flow is set using **[Col 1]** or **[Col 2]**. This parameter is not available if your column is not defined.

Split flow Flow, in mL/min, from the split vent. This parameter is not available if your column is not defined.

Total flow The total flow into the interface, both setpoint and actual

Septum Purge Flow through the septum purge vent

Gas saver On to reduce split vent flow at **Saver time**

Saver flow Reduced split vent flow, at least 15 mL/min.

Saver time Time when flow is reduced to save gas

If the column is defined

- 1 Press **[Front Inlet]** or **[Back Inlet]**.
- 2 Scroll to **Mode:** and press **[Mode/Type]**. Select **Split**.
- 3 Set the interface temperature.
- 4 If you want a specific split ratio, scroll to **Split ratio** and enter that number. The split flow will be calculated and set for you.
- 5 If you want a specific split flow, scroll to **Split flow** and enter that number. The split ratio will be calculated and set for you.
- 6 If desired, turn **Gas saver** on. Set **Saver time** after the sample has been introduced.
- 7 If **Gas saver** is on, be certain **Auto prep run** is On (see “[Pre Run and Prep Run](#)” on page 171) or press **[Prep Run]** before introducing the sample.

If the column is not defined

- 1 Press **[Front Inlet]** or **[Back Inlet]**.
- 2 Scroll to **Mode:** and press **[Mode/Type]**. Select **Split**.
- 3 Set the interface temperature.
- 4 Set **Total flow** into the interface. Measure flow out of the split vent using a flow meter.
- 5 Subtract the split vent flow from **Total flow**. Subtract the septum purge flow from the result to get column flow.

- 6 Calculate the split ratio (split vent flow/column flow). Adjust as needed.
- 7 If desired, turn **Gas saver** on. Set **Saver time** after the sample has been introduced.
- 8 If **Gas saver** is on, be certain **Auto prep run** is On (see “[Pre Run and Prep Run](#)” on page 171) or press [**Prep Run**] before introducing the sample.

About the VI splitless mode

This mode is used to concentrate sample at the head of the GC column during desorb. Purge timing delay must take into consideration the volume of the loop or trap in the external sampler plus the transfer line versus desorb/total flow rate. Cryo focussing is required for very volatile samples in splitless mode.

When you introduce a sample, the split valve remains closed while the sample enters the interface and is transferred to the column. At a specified time after the sample is introduced, the split valve opens.

Splitless mode pneumatics

Before Pre Run When the GC is preparing for sample introduction, total flow to the interface is measured by a flow sensor and controlled by a proportional valve. Column flow is controlled via back- pressure regulation. The split valve is open.

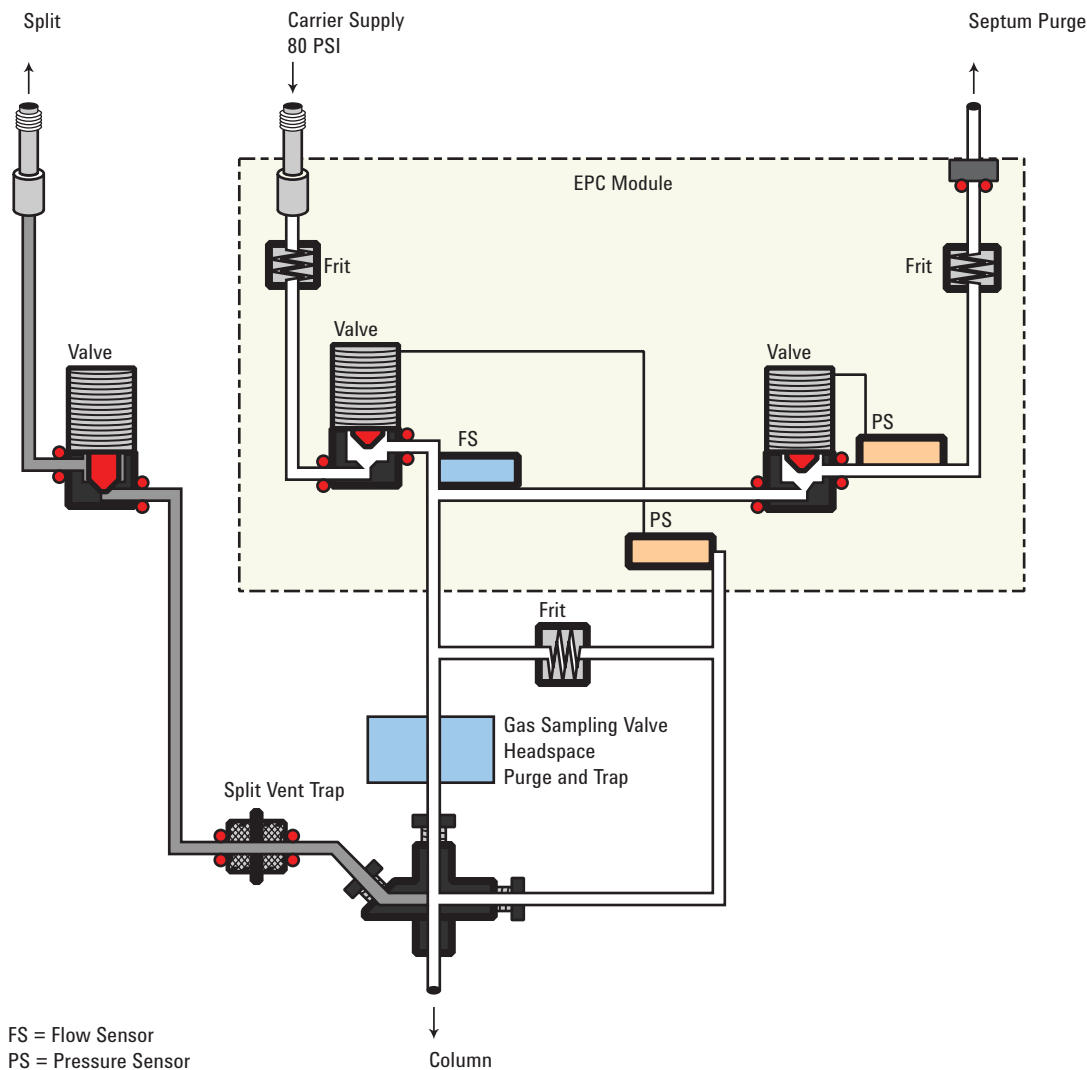

During sampling Pressure upsets caused by switching valves and trap restrictions in the external sampling device can cause fluctuations in column flow rates. To compensate for this, the interface is flow controlled during sampling time. The sampling flow rate is calculated from the pressure setpoint that is active when sample introduction begins. This flow control starts when the GC goes into the Pre Run state (when your system is automated and the Pre Run light is on or during manual operation when you press [**Prep Run**]) and ends after the interface's **Sampling end** setpoint expires.

Sampling end is required for purge and trap or thermal desorption systems and should be set \geq the sampler desorb time.

During this user- specified sampling period, the solenoid valve is closed. Flow to the interface is measured by a flow sensor and controlled by a proportional valve.

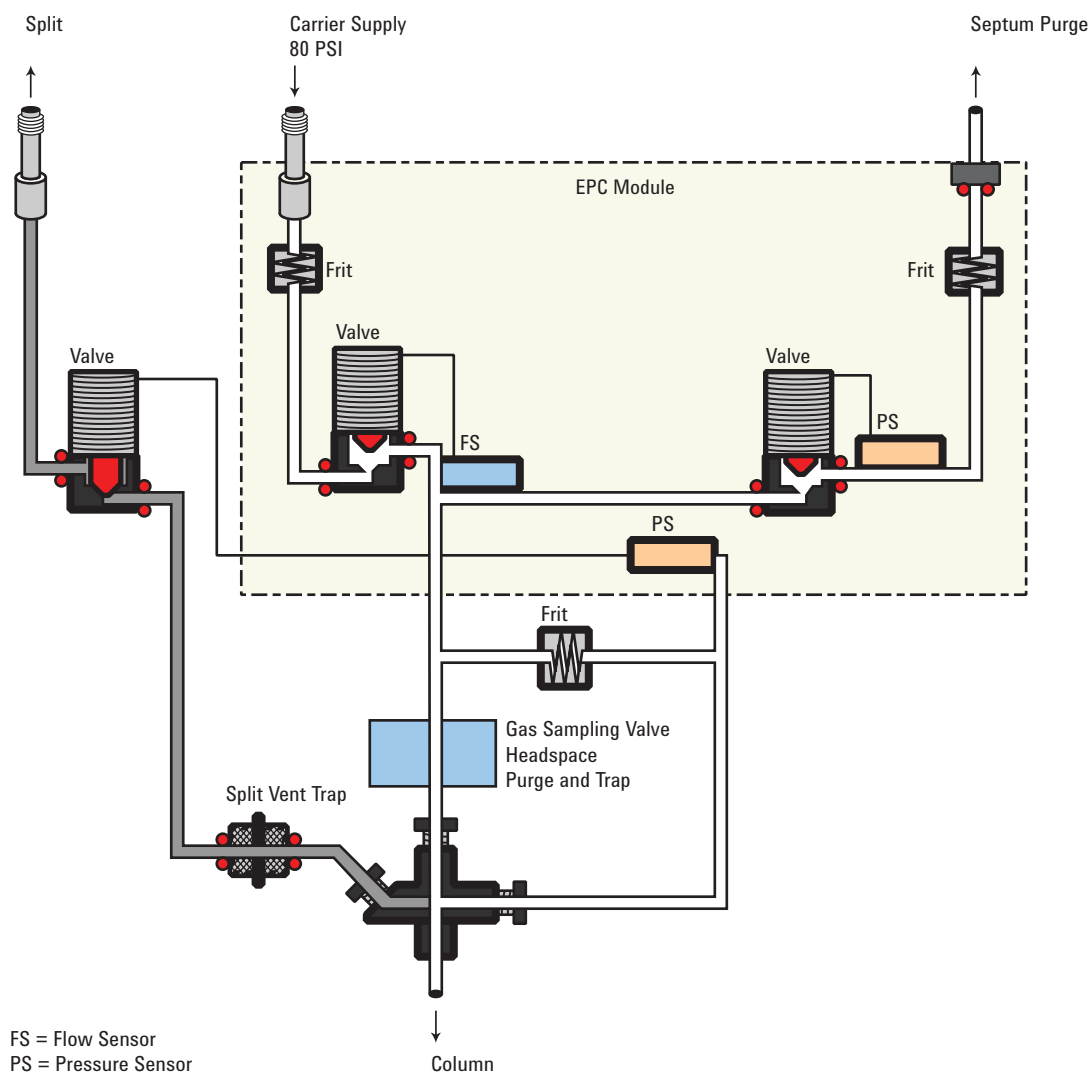

After sampling end The solenoid valve opens. The system returns to the **Before Prep Run** state. Flow to the interface is again measured by a flow sensor and controlled by a proportional valve while column flow is controlled via back- pressure regulation. The purge flow is controlled by the user. If desired, gas saver can be turned on at the end of the run.

Setpoint dependencies

Some setpoints in the flow system are interdependent. If you change one setpoint, other setpoints may change to compensate.

Table 56 Setpoint dependencies

When you change	These setpoints change	
	Column defined	Column not defined
Purging		You can change the Pressure and Total flow setpoints; other setpoints are not affected.
Purge flow	Total flow**	
Pressure	Total flow** Column flow*	
Column flow*	Pressure Total flow**	
Before and after sampling, not purging		You can change the Pressure setpoint; other setpoints are not affected.
Pressure	Column flow* Total flow**	
Column flow*	Pressure Total flow**	
During sampling: You cannot change pressure and flow setpoints during sampling time.		

* This setpoint appears in the column parameters.

**This value is actual only.

Initial values

The table shows recommended starting values for selected parameters.

Table 57 Suggested starting values

Parameter	Allowed setpoint range	Suggested starting value
Oven initial time	0 to 999.9 minutes	≥ Interface purge time
Interface temperature	Ambient + 10 °C to 400 °C	≥ Transfer line temperature
Interface sampling end	0 to 999.9 minutes	0.2 minutes longer than introduction time

Table 57 Suggested starting values (continued)

Parameter	Allowed setpoint range	Suggested starting value
Interface purge time	0 to 999.9 minutes	
Gas saver time	0 to 999.9 minutes	Must be after purge time
Gas saver flow	15 to 100 mL/min	15 mL/min greater than maximum column flow

Setting parameters for the VI splitless mode

Mode: The current operating mode—splitless

Temperature Actual and setpoint interface temperatures. Column temperature must be low enough to cold trap the volatile sample. Cryo focussing is recommended.

Sampling end The sample introduction interval, in minutes. The flow rate is calculated from the pressure setpoint that is active at the start of sample introduction.

Set the sampling end setpoint 0.2 minutes longer than the time the sampler needs to introduce the sample. For example, the 7694 headspace sampler has an Inject time parameter which controls how long the valve remains in the inject position. If Inject time is 1 minute, the sampling end setpoint should be set to 1.2 minutes. If you're using an 7695 Purge and Trap Concentrator, set **Sampling end** 0.2 minutes longer than the Desorb time parameter.

If your column is defined and you specify a flow or pressure program for your column, the ramp does not begin until after the sampling end setpoint expires.

Pressure Actual and setpoint interface pressure in psi, bar, or kPa.

Purge time The time, after the beginning of the run, when purging resumes. **Purge time** must be greater than **Sampl'g end**.

Purge flow The flow, in mL/min, from the split vent at **Purge time**. You will not be able to access or specify this value if your column is not defined.

Total flow When your column is defined, **Total flow** displays the actual flow to the interface. You cannot enter a setpoint. If your column is not defined, **Total flow** will have both setpoint and actual values during purge time. All other times, the actual flow to the interface is displayed.

Septum Purge Flow through the septum purge vent, at least 15 mL/min.

Gas saver On to reduce split vent flow at **Saver time**.

Saver flow Flow through the split vent after **Saver time**.

These instructions apply to both column *defined* and *not defined*.

- 1 Press [**Front Inlet**] or [**Back Inlet**].
- 2 Scroll to **Mode:** and press [**Mode/Type**]. Select **Splitless**.
- 3 Set the interface temperature and a sampling end time.
- 4 If your column is defined, enter a **Purge time** and **Purge flow**. Turn **Gas saver** on if desired. Set the **Gas saver time** *after* the purge time and enter a Gas saver flow.
- 5 If your column is not defined, enter a **Purge time** (**Purge flow** is not available). Set **Total flow** greater than column flow plus septum purge flow to guarantee adequate column flow.
- 6 Make certain **Auto Prep Run** is **On** (see “[Pre Run and Prep Run](#)” on page 171) or press [**Prep Run**] before introducing a sample.

About the VI direct mode

Direct sample introduction permits a quantitative transfer of analyte without risking contamination to the pneumatic system. It provides the sensitivity required for air toxic analyses. The interface’s minimal dead volume also eliminates the potential interaction of solutes with poorly swept, active surfaces.

To operate in the direct mode, you must physically disconnect the split vent and reconfigure the GC.

Before Pre Run

The interface is forward pressure controlled; pressure is sensed downstream from the flow proportional valve.

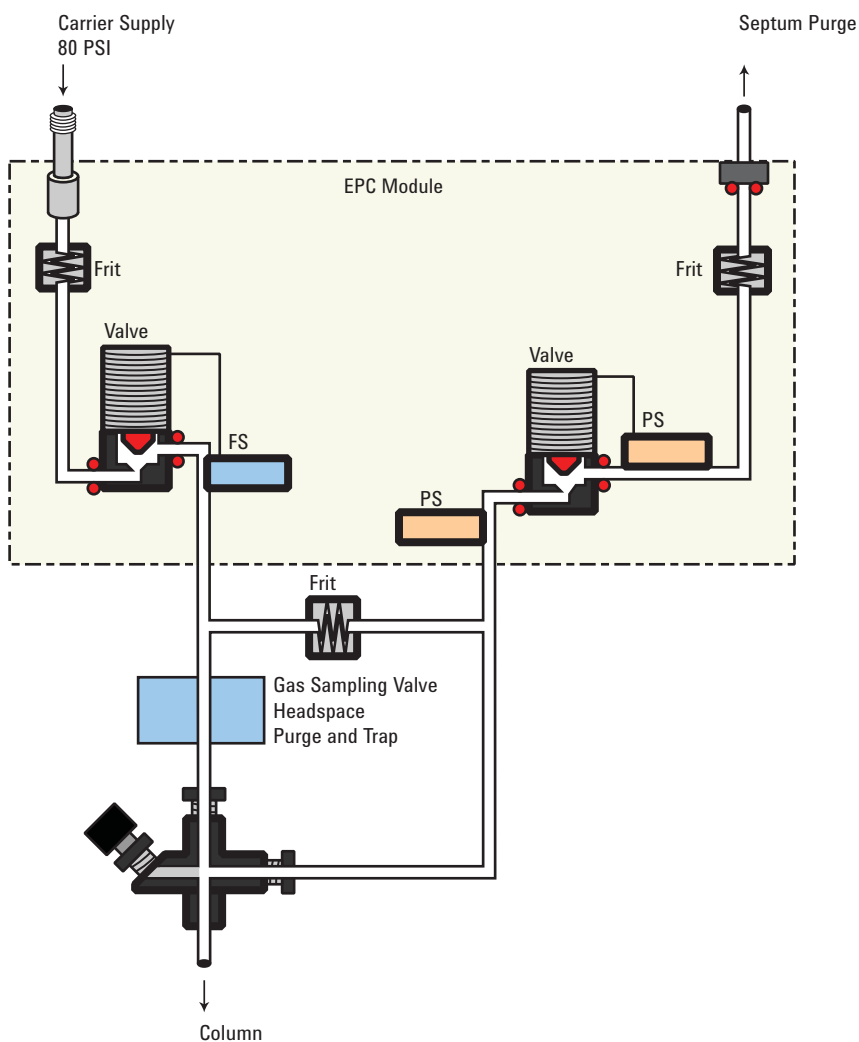

During sampling

Pressure upsets caused by switching valves in the external sampler can cause fluctuations in column flow rates. To compensate for this, the interface is flow controlled during sampling time. The sampling flow rate is calculated from the pressure setpoint that is active when sample introduction begins. This flow control starts when the GC goes into the Pre Run state (when your system is automated and the Pre Run light is on or during manual operation when you press [Prep Run]) and ends after the interface's **Sampling end** setpoint expires.

Flow to the interface is measured by a flow sensor and controlled by a proportional valve.

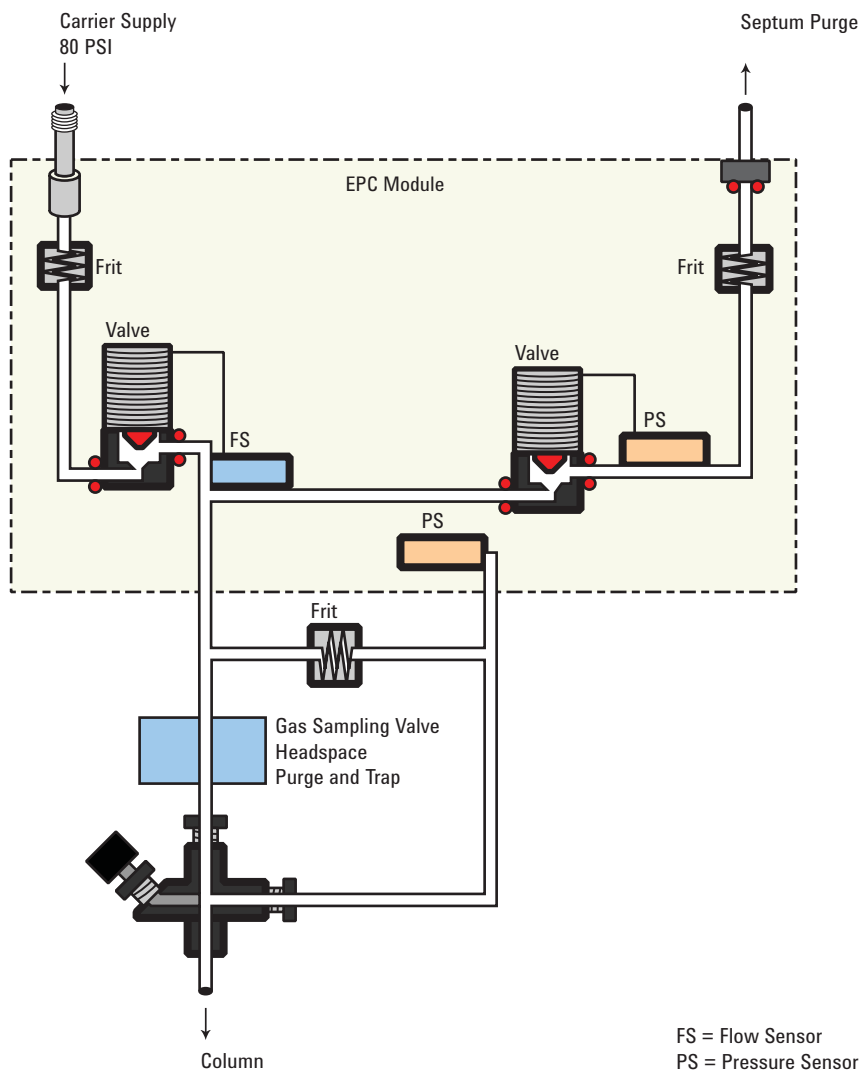

After sampling end

The interface is forward pressure controlled; pressure is sensed downstream from the proportional valve. The system returns to the idle state.

Preparing the Interface for Direct Sample Introduction

Before you can operate your interface in direct mode, you must:

- Disconnect the split vent line
- Configure the GC for a direct injection

Disconnecting the split vent line

WARNING

Be careful! The interface may be hot enough to cause burns.

- 1 Press [**Front Inlet**] or [**Back Inlet**]. Turn off the interface temperature and pressure and allow the interface to cool.
- 2 If desired, remove the transfer line by loosening the hex nut with a wrench.
- 3 Remove the clamping plate from the interface by loosening the captive screw with a screwdriver. Put the plate in a safe place.

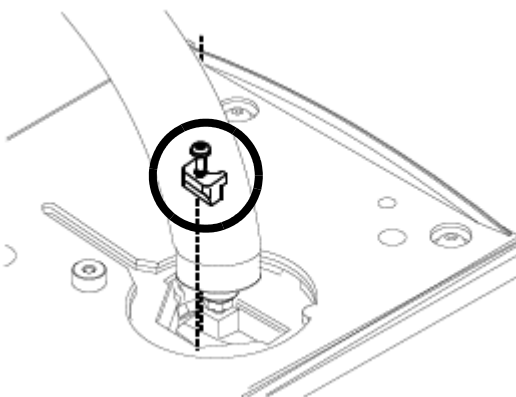

- 4 Carefully lift the interface out of the heater block.

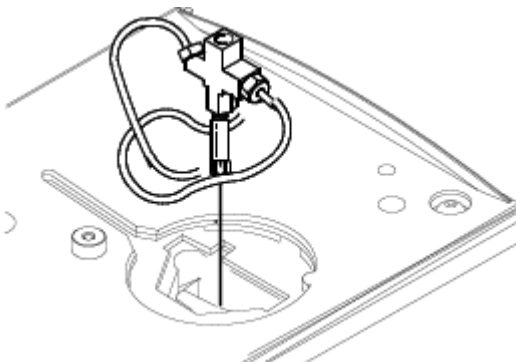

- 5 Loosen the hex nut connecting the split vent line to the interface until you can remove the line. Put the line aside. You do not need to plug it.

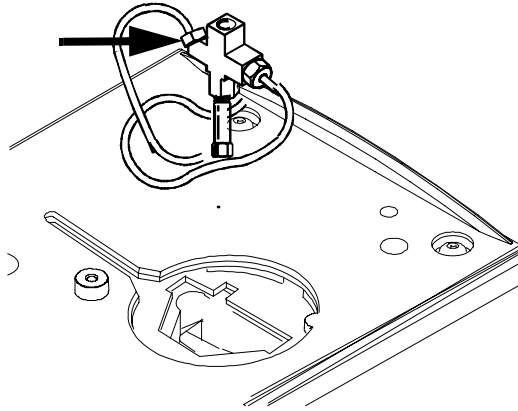

- 6 Install a blanking nut into the split line port and finger-tighten the nut. Tighten the nut an additional 1/4- turn using two wrenches in opposition.

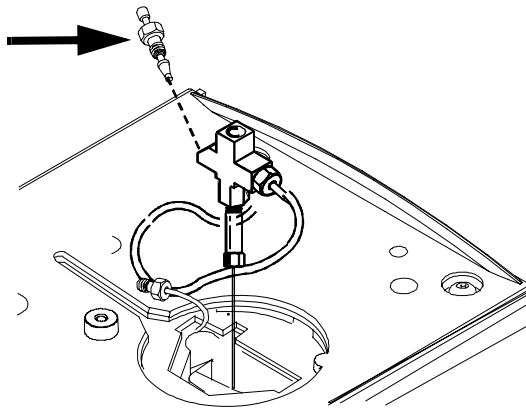

- 7 Place the interface in the heater block. Replace the clamping plate you removed earlier and tighten the screw until snug. Do not overtighten. If you removed the transfer line, replace it.

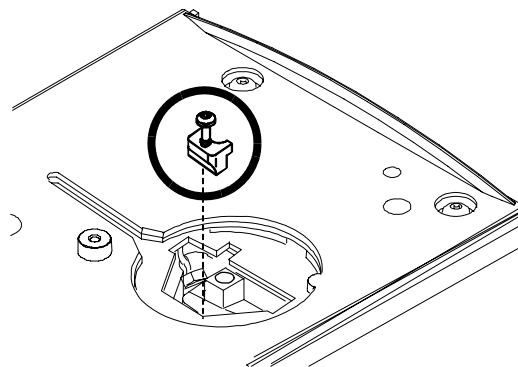

- 8 Restore the GC to normal operating conditions. Perform a leak test on the interface fittings.

Configuring for direct mode

The GC cannot sense the presence of the split vent. When you disconnect or reconnect the vent, you must configure the GC so that the pneumatics work properly.

- 1 Press [**Config**][**Back Inlet**] or [**Config**][**Front Inlet**].
- 2 Scroll to **Mode** and press [**Mode/Type**].
- 3 Select **Split vent removed**. Press [**Enter**].
- 4 Press [**Back Inlet**] or [**Front Inlet**]. If the inlet is correctly configured, you will see the **Direct injection** display.

VI direct mode setpoint dependencies

Some setpoints in the flow system are interdependent. If you change one setpoint, other setpoints may change to compensate.

Table 58 Setpoint changes

When you change	These setpoints change	
	Column defined	Column not defined
Before and after sampling		The Column flow* setpoint is not available.
Pressure	Column flow* Total flow**	You can change the pressure setpoint; other setpoints are not affected.
Column flow*	Pressure Total flow**	
During sampling	You cannot change pressure and flow setpoints during sampling time.	

* This setpoint appears in the column parameters

**This value is actual only

VI direct mode initial values

Use the information in [Table 59](#) to help you set up the operating conditions for your interface.

Table 59 Suggested starting values

Parameter	Allowed setpoint range	Suggested starting value
Oven initial time	0 to 999.9 minutes	≥ interface sampling end
Interface temperature	Ambient + 10 °C to 400 °C	≥ transfer line temperature
Interface sampling end	0 to 999.9 minutes	0.2 minutes longer than actual sampling time

Setting parameters for the VI direct mode

Temperature Actual and setpoint interface temperatures

Sampling end The sample introduction interval, in minutes. The flow rate is calculated from the pressure setpoint that is active at the start of sample introduction.

Set **Sampling end** 0.2 minutes longer than the time the sampler needs to introduce the sample. For example, the 7694 headspace sampler has an **Inject time** parameter which controls how long the valve remains in the inject position. If **Inject time** is 1 minute, **Sampling end** should be set to 1.2 minutes. If you're using a 7695 Purge and Trap Concentrator, set **Sampling end** 0.2 minutes longer than the **Desorb time** parameter.

If your column is defined and you specify a flow or pressure program for your column, the ramp does not begin until after **Sampling end** expires.

Pressure Actual and setpoint interface pressure before a run and after sampling time.

Total flow The actual flow to the interface. This is a reported value, not a setpoint.

Septum Purge Flow through the septum purge vent, range 0 to 30 mL/min.

These instructions apply to both column defined and column not defined.

- 1 Press [**Front Inlet**] or [**Back Inlet**].
- 2 Confirm that your GC is configured for direct injection.
- 3 Set the interface temperature.

- 4 Set **Sampling end** at 0.2 minutes longer than the sample introduction time.
- 5 Make certain **Auto Prep Run** is On (see “[Pre Run and Prep Run](#)” on page 171) or press [**Prep Run**] before introducing a sample.

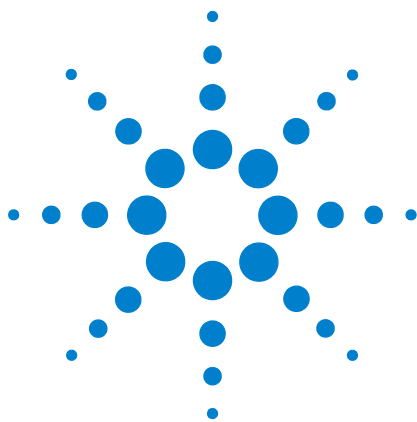

9 Columns and Oven

- About the Oven [276](#)
 - Oven safety [276](#)
- Configuring the Oven [277](#)
- Cryogenic Operation [278](#)
 - Cryogenic setpoints [278](#)
- About Oven Temperature Programming [280](#)
 - Programming setpoints [280](#)
 - Oven ramp rates [281](#)
 - Setting the oven parameters for constant temperature [282](#)
 - Setting the oven parameters for ramped temperature [282](#)
- About the Oven Insert [284](#)
 - Selecting the correct packed glass column type [285](#)
 - About the column modes [285](#)
 - Select a column mode [286](#)
 - Setting the column parameters for constant flow or constant pressure [287](#)
 - Enter a flow or pressure program (optional) [287](#)
 - Programming column pressure or flow [288](#)
- About Columns [285](#)
- Backflushing a Column [289](#)
 - Backflushing when connected to an MSD [289](#)
- Nickel Catalyst Tube [295](#)
 - About the nickel catalyst tube [295](#)
 - Nickel catalyst gas flows [295](#)
 - Setting temperatures for the nickel catalyst tube [296](#)

About the Oven

Table 60 Oven capabilities

Capability	Range
Temperature range	–80 °C (liquid N ₂) or –40 °C (CO ₂) to the configured limit
Maximum temperature	450 °C
Temperature programming	Up to six ramps
Maximum run time	999.99 minutes
Temperature ramp rates	0 to 120 °C/min, depending on instrument configuration

Oven safety

For safety, opening the oven door turns off power to the oven heater, fan, and cryogenic valve (if installed) but maintains the setpoints in memory.

Closing the oven door returns the oven to normal operation.

If the oven cannot attain or maintain an entered setpoint temperature during normal above-ambient operation, a problem is assumed and the oven is switched off.

Possible problems include:

- The oven vent flaps not working
- The oven fan, heater, or temperature sensor not working properly
- An electronic problem

When a shutdown occurs, the **Off** line in the oven parameter list blinks and the oven remains off until switched on again by pressing **[Oven][On]** or by editing the **Temperature** setpoint.

Configuring the Oven

Oven configuration sets maximum temperature, equilibration time the cool down mode, and the cryogenic setpoints, if cryo is installed.

Maximum temperature Maximum allowable oven temperature setpoint. Some accessories, such as the valve box, valves and columns have specific temperature limits. When configuring **Maximum temperature**, these limits should be considered so that the accessories are not damaged. Oven setpoints are verified as they are entered; a message is displayed when an entered setpoint is inconsistent with a previously defined maximum.

Equilibration time The time required for the oven temperature to equilibrate after temperature is modified. Equilibration time begins when the actual oven temperature comes within 1 °C of the oven temperature setting. The **Equilibration time** setpoint can be 0 to 999.99 minutes.

Cryo See “[Cryogenic Operation](#)”.

External oven mode Press the GC [Info] key for details.

Slow oven cool down mode During the oven cooling period, the fan can operate at full speed or at a reduced speed. This parameter makes the choice.

Cryogenic Operation

The cryogenic valve lets you operate the oven below ambient temperature. Minimum attainable oven temperature depends on the type of valve installed.

The GC senses the presence and type of cryogenic valve and disallows setpoints if no valve is installed. When cryogenic cooling is not needed or cryogenic coolant is not available, the cryogenic operation should be turned off. If this is not done, proper oven temperature control may not be possible, particularly at temperatures near ambient.

Cryogenic setpoints

Equilibration time Set from 0 to 999.999 minutes.

Cryo [ON] enables cryogenic cooling, [OFF] disables it.

Quick cryo cool This is separate from **Cryo**. **Quick cryo cool** cools the oven faster after a run than it would without assistance. This is useful when maximum sample throughput is necessary, however it does use more coolant. **Quick cryo cool** turns off soon after the oven reaches its setpoint and **Cryo** takes over, if needed.

Ambient temp The temperature in the laboratory. This setpoint determines the temperature at which cryogenic cooling is enabled.

- Ambient temp + 25 °C, for regular cryo operation
- Ambient temp + 45 °C, for Quick Cryo Cool.

Cryo timeout Cryo timeout occurs, and the oven shuts off, when a run does not start within a specified time (10 to 120 minutes) after the oven equilibrates. Turning cryo timeout **Off** disables this feature. We recommend that it be turned **On** because cryo timeout conserves coolant at the end of a sequence or if automation fails.

Cryo fault Shuts the oven down if it does not reach setpoint temperature after 16 minutes of continuous cryo operation. Note that this is the time to *reach* the setpoint, not the time to stabilize and become ready at the setpoint. For example, with a cool on-column inlet and cryo control in the track oven mode, it may take the oven 20 to 30 minutes to achieve readiness.

If the temperature goes below the minimum allowed temperature ($-90\text{ }^{\circ}\text{C}$ for liquid nitrogen, $-70\text{ }^{\circ}\text{C}$ for liquid CO_2), the oven will shut down.

External oven mode Isothermal internal mode and programmed external oven used to calculate column flow.

Slow oven cool down mode **On** to run oven fan at slow speed during cool down.

About Oven Temperature Programming

You can program the oven temperature from an initial temperature to a final temperature using up to 20 ramps during a run.

A single ramp temperature program raises the initial oven temperature to a specified final temperature at a specified rate and holds at the final temperature for a specified period of time.

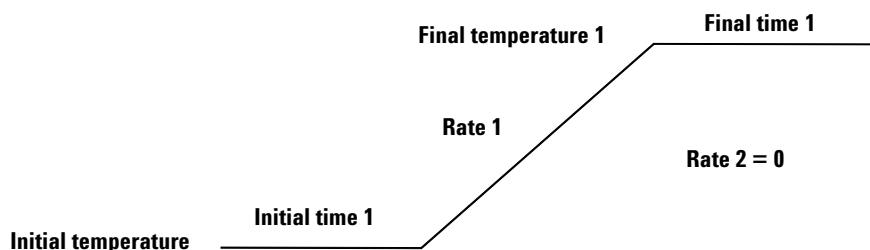

The multiple-ramp temperature program is similar. You can program the oven from an initial temperature to a final temperature, but with various rates, times, and temperatures in between. Multiple ramps can also be programmed for temperature *decreases* as well as increases.

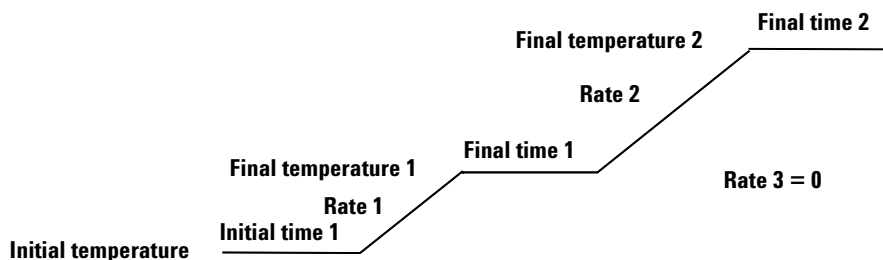

Programming setpoints

Temperature Starting temperature of a temperature programmed run. When the program begins, this value is copied into a temporary setpoint called **Init temp**. At the end of the run, **Temperature** is reset to the value in **Init temp** and the oven returns to its starting temperature.

Initial time Time in minutes that the oven will stay at the starting temperature after a programmed run has begun.

Rate The rate in °C/min at which the oven will be heated or cooled.

Final temperature Temperature of the oven at the end of a heating or cooling rate.

Final time Time in minutes that the oven will be held at the final temperature of a temperature-programmed rate.

Total length of a run is determined by its oven temperature program. The maximum allowable time for a run is 999.99 minutes. If the program is still running at that time, the run terminates.

Post run

This function can be used with both isothermal and programmed methods. Post run is a period that begins at the end of the normal run. The parameters are:

- **Time**—How long is the post run period?
- **Temperature**—What is the oven temperature during the post run period?
- **Column pressures**—What are the pressures at the column ends?

Post run may be used to clean out a column in preparation for the next run, backflush a column to eliminate high-boilers, and other functions.

When the Post run **Time** elapses, the GC returns to the initial state defined in the current method. If it uses cryogenic cooling and you do not start another run quickly, you could waste considerable coolant while waiting for the next run. A solution is to use a sequence that loads a less wasteful method.

Oven ramp rates

To use the fast oven ramp rates (a 240 V power option is required), your electric service must be able to supply ≥ 200 V at ≥ 15 Amp.

The highest rate that you can achieve depends on many factors, including the room temperature, temperatures of the inlets and detectors, the amount of material inside the oven (columns, valves, etc.), and whether or not this is the first run of the day.

The optional oven insert for fast chromatography (see [“About the Oven Insert”](#) on page 284), increases oven ramp rates for the back column. [Table 61](#) lists typical oven ramp rates.

Table 61 Oven ramp rates

Temperature range (°C)	100/120 V oven ramp rate (°C/minute)		200/220/230/240 V oven ramp rate (°C/minute)	
	Without insert	With optional insert	Without insert	With optional insert
50 to 70	75	120	120	120
70 to 115	45	95	95	120
115 to 175	40	65	65	110
175 to 300	30	45	45	80
300 to 450	20	35	35	65

Setting the oven parameters for constant temperature

An isothermal run is one in which the oven is maintained at a constant temperature. For an isothermal run, set **Rate 1** to zero.

- 1 Press [**Oven**] to open the oven parameter list.
- 2 Enter the oven temperature for the isothermal run.
- 3 Enter the number of minutes (**Initial time**) that you want the oven to stay at this temperature. This time is the duration of the run.
- 4 If **Rate 1** is not already **0**, enter zero for an isothermal run.

Setting the oven parameters for ramped temperature

Single ramp

- 1 Press [**Oven**] to open the oven parameter list.
- 2 Enter a starting temperature (**Temperature**).
- 3 Enter the time (**Initial time**) that you want the oven to stay at **Temperature**.
- 4 Enter the rate (**Rate 1**) at which the oven temperature is to change.
- 5 Enter the final temperature (**Final temperature 1**).
- 6 Enter the time (**Final time 1**) the oven is to hold **Final temperature 1**.
- 7 To end the oven ramp program after **Ramp 1**, set **Rate 2** to zero.

Multiple ramps

In a multiple-ramp program, **Final time** for one ramp is also **Initial time** for the next ramp. Thus, there is only one **Initial time**.

- 1 Set up the first oven ramp as described in “Single ramp”.
- 2 Enter the rate (**Rate 2**) at which you want the oven temperature to increase for the second oven ramp.
- 3 Enter the final temperature (**Final temperature 2**).
- 4 Enter the number of minutes (**Final time 2**) that you want the oven to hold the final temperature.
- 5 To end the temperature program after the second ramp, set **Rate 3** to zero.
- 6 To add additional oven ramps, repeat the steps described.

About the Oven Insert

The Oven Insert for Fast Chromatography reduces the oven volume so that the column and sample heat more quickly, yielding faster separation and faster chromatography. Furthermore, the smaller volume oven cools faster than a full-sized oven, reducing the overall analytical cycle time.

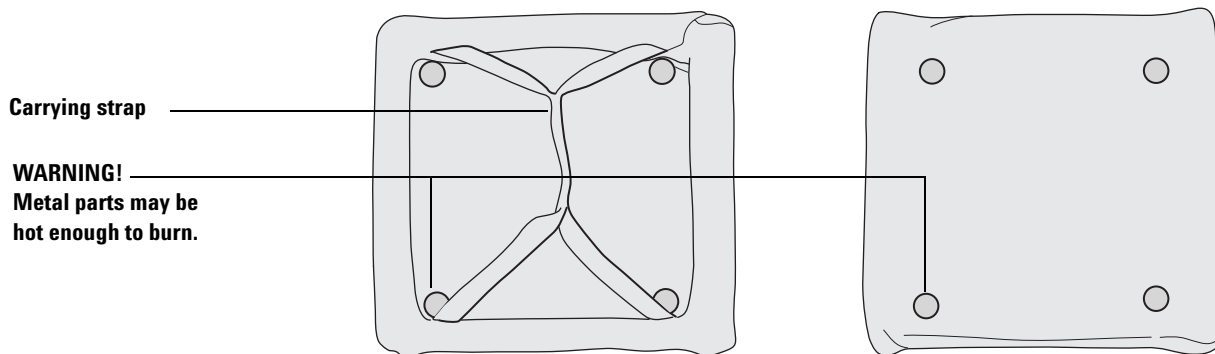

The oven insert is used with any inlet, column, and detector mounted in the **back** position. It is not compatible with any accessory which obstructs access to the front of the oven or which requires the use of either the front inlet or the front part of the oven.

About Columns

In all GCs, a sample—which is a mixture of several components—is vaporized in an inlet, separated in a column, and examined in a detector.

The column separates components in time because:

- When a vaporized component is presented with a gas phase and a coating phase, it divides between the two phases according to its relative attraction to the two phases.
- The “attraction” can be solubility, volatility, polarity, specific chemical interaction, or any other property that differs from one component to another.
- If one phase is stationary (the coating) and the other is moving (the carrier gas), the component will travel at a speed less than that of the moving phase. How much less depends on the strength of the attraction.
- If different components have different “attractions”, they will separate in time.

Selecting the correct packed glass column type

This topic is covered in the Maintenance manual. See [To attach a packed column to the purged packed inlet](#) for details.

About the column modes

The flow modes available are determined by the GC inlet’s control mode. When the inlet’s control mode is set to **Pressure control**, all of the flow modes and pressure modes below are available for the column. When the inlets control mode is set to **Flow control**, the column’s mode is not selectable. For an inlet’s mode of **Flow control**, only column flow can be entered.

The flow modes

Flow rates are corrected to NTP (normal temperature and pressure, 25 °C and 1 atmosphere).

- **Constant flow**—Maintains a constant mass flow rate of carrier gas in the column throughout the run. If the column resistance changes due to a temperature program, the column head pressure is adjusted to keep the flow rate constant. This can shorten runs significantly.

- **Ramped flow**—Increases the mass flow rate in the column during the run according to a program you enter. A column flow profile can have up to three ramps, each consisting of a programmed increase followed by a hold period.

The pressure modes

The pressure modes are not available if the column is not defined or the inlet's mode is set to **Flow control**.

Pressures are gauge pressures—the difference between the absolute pressure and the local atmospheric pressure. Because most detectors present little resistance to the column flow, the gauge pressure at the column head is usually the same as the pressure difference between column inlet and exit. The mass selective detector and the atomic emission detector are the exceptions.

- **Constant pressure**—Maintains a constant gauge pressure at the head of the column throughout the run. If the column resistance and gas density changes during a run, the gauge pressure does not change but the mass flow rate does.
- **Ramped pressure**—Increases the column head gauge pressure during the run according to a program you enter. A column pressure profile can have up to three ramps, each consisting of a programmed increase followed by a hold period.

Select a column mode

The column's mode parameter is not available if the inlet's mode parameter is set to **Flow control**.

When a splitter controlled by a PCM or AUX pressure is used to divide flow between multiple columns, only the mode setting of the lowest column number configured determines the mode used. All other column mode settings exiting the splitter are ignored by the GC.

- 1 Press **[Col 1]** or **[Col 2]**, or press **[Aux col #]** and enter the column number.
- 2 Scroll to the **Mode** line.
- 3 Press **[Mode/Type]** to see the column mode list.
- 4 Scroll to the column mode you want. Press **[Enter]**.

This completes column mode selection. Next you must specify the inlet conditions either during the entire run (if you selected either of the constant modes) or at the beginning of the run (if you selected either of the ramped modes).

Setting the column parameters for constant flow or constant pressure

If the column is defined, you can enter any one of these quantities—the GC will calculate and display the other two.

For example, you may have selected **Constant pressure** as the column mode. You decide to specify, as a starting condition, the column flow. The GC will compute the pressure necessary to achieve this flow (as well as the average linear velocity) and hold this *pressure* constant during the run.

If you select **Constant flow** as the mode and specify column flow as the initial condition, the GC will still calculate the pressure necessary to achieve this flow, but it will adjust the pressure as necessary to maintain constant flow.

If the column is not defined, you can enter only pressure. Constant flow can still be specified, but the GC cannot know what the flow is.

- 1 Press [**Col 1**] or [**Col 2**], or press [**Aux col #**] and enter the column number.
- 2 Scroll to the **Pressure** or **Flow** or **Velocity** line.
- 3 Type the desired initial value, followed by [**Enter**]. The GC will compute and display the other two values. Adjust them, if you choose to, by repeating steps 2 and 3 but note that changing any one changes all three.

This completes setting the initial carrier gas condition.

Enter a flow or pressure program (optional)

If you selected either the ramped pressure or ramped flow column mode, the column parameter list contains entries for setting up a ramp program.

You begin with an initial value, either **Initial Pressure** or **Initial Flow**, and an **Initial time**. At the end of that time, **Rate 1** begins and runs until it reaches **Final pressure** (or **Final flow**). It remains at that value for **Final time 1**. You can then add a second and third ramp, each consisting of a Rate, a Final value (pressure or flow), and a Final time.

The program ends when it reaches a **Rate** that is set to 0 (**Off**).

When a flow or pressure program is running, the **Pressure**, **Flow**, and **Velocity** lines that you used to set constant conditions show the progress of the program.

The oven program determines the length of the run. If a flow or pressure program ends before the analytical run does, the flow (or pressure) remains at the last final value.

Programming column pressure or flow

- 1 Press [**Col 1**] or [**Col 2**], or press [**Aux col #**] and enter the column number.
- 2 Scroll to **Initial pressure** (or **Initial flow**). Type the desired value and press [**Enter**].
- 3 Similarly, enter a value for **Initial time**. This completes the initial part of the program.
- 4 To begin a ramp, enter a positive value for **Rate 1**. It does not matter whether you are programming up or down—the rate is always positive.
- 5 If **Rate 1** is zero, the program ends here. If you enter any other value, the Final value lines for the first ramp appear and the cursor moves to the line.
- 6 Enter values for **Final pressure 1** (or **Final flow 1**) and **Final time 1**. This completes the first ramp.
- 7 To enter a second ramp, scroll to the appropriate **Rate** line and repeat steps 5 and 6. A maximum of 20 ramps can be entered.

Backflushing a Column

Backflush is a means of discarding high-boilers from a column after the peaks of interest have eluted. It saves analysis time and has these additional benefits:

- Longer column life
 - less high temperature exposure
 - removal of high-boilers
 - protection from air and water at high temperatures
- Less chemical background
 - ghost peaks
 - “wrap-around” of late eluters from previous runs
 - stationary phase decomposition peaks
- Less contamination of the mass selective detector (MSD) source, if using MSD
 - longer time between source cleanings
 - higher stability of calibrations

You will need to experimentally determine the correct flow/pressure settings and the backflush time appropriate for your analysis. Determine the correct values by testing the backflush method, then running a blank to check for residual late eluters.

CAUTION

Only backflush an inlet that has a split vent line with a chemical trap, such as the split/splitless, PTV, and VI. Attempts to backflush using other inlet types will most likely damage the pneumatics flow modules.

Refer to the Agilent web site at <http://www.agilent.com/chem> for example backflush applications, especially if using an MSD.

Backflushing when connected to an MSD

If using an MSD with the GC, backflushing becomes more complex. Set up backflush as a post run event by using the Backflush Wizard present in the MSD Productivity ChemStation.

Backflushing using a capillary flow technology device

Because the following capillary flow technology (CFT) devices connect to a controlled carrier gas supply, they can be used to backflush a column:

- G2855B Capillary Flow Technology Deans Switching System
- G3180B Capillary Flow Technology Two- Way Splitter (with makeup gas)
- G3183B Capillary Flow Technology Three- Way Splitter
- G3185B QuickSwap Accessory

A conceptual diagram for a simple setup is shown in the figure.

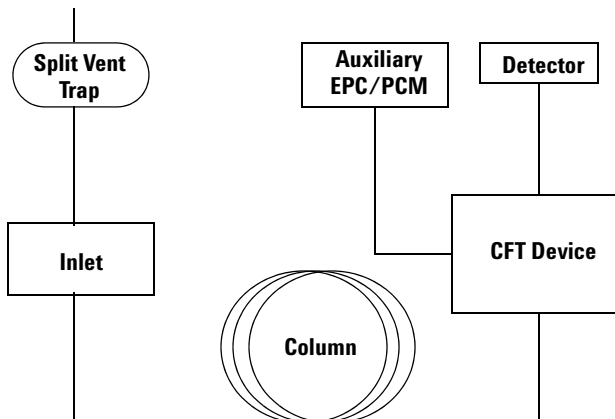

After the last analyte of interest elutes, you can program a decrease in inlet column flow with an increase in the pressure/flow from the Aux EPC or PCM connected to the CFT device, thereby reversing column flow and forcing the remaining analytes off the column and out of the inlet split vent. You can do this using a post run program or as a ramped pressure or flow program.

To set up a post run backflush

A main advantage of the post- run backflush method is that the GC turns off detection during this time. If using an MSD, this helps prevent damage to the detector and is the recommended backflush method.

If using an Agilent data system, a Backflush Wizard provides a straightforward interface for making these settings.

- 1 Verify that all columns are properly configured.
- 2 Since the backflush will run as a post-run program, set the method so that the oven program ends after the last peak of interest returns to baseline, or after reaching the last temperature of interest.
- 3 Press [**Post Run**] and enter the backflush duration as the **Time**.
 - The oven temperature and column pressure/flow setpoints for installed columns appear.
 - Whether you can enter a pressure or flow for a column depends on its mode (pressure or flow).
- 4 Enter the oven temperature for the backflush.
- 5 Enter the backflush flow(s) or pressure(s).

If in flow mode:

- Enter a negative flow for the column connected between the inlet and the CFT device. The GC will automatically establish the corresponding pressures needed in the inlet and the CFT device.
- Increase the flow rates in the column(s) connected between the CFT device and the detector(s).

If in pressure mode:

- Set the pressure of the column connected between the inlet and the CFT device to 0.000. This turns off flow from the inlet.
- Increase the pressure of the primary column connected between the CFT device and the detector(s). This creates the backward flow through the column and increases the flow through any connected detectors.

When developing the backflush portion of your method, consider the following:

- Ensure that the split vent flow setpoint is at least 25 mL/min and at least 50% more than the column backflush flow rate.
- If using gas saver, ensure that the gas saver flow setpoint is at least 25 mL/min and at least 50% more than the column backflush flow rate.

To backflush using a ramped pressure program

In this case, the backflush occurs as part of the run, so the detectors continue to collect data. During the backflush, you may wish to turn off data collection in the data system.

CAUTION

To avoid damage to an MSD, Agilent strongly recommends setting up backflush as a post run event, not as part of a ramped column program. If you still choose to backflush as part of a run, be very careful that the flow into the MSD does not exceed the limits of the vacuum pump.

- 1 Verify that all columns are properly configured.
- 2 Enter all method parameters for the analysis: sampler parameters, inlet parameters, oven temperature profile, detector flows and temperatures, and so forth.
- 3 Program the oven for the backflush.
 - Include any temperature profile needed for backflush.
 - Set the total run time to include sufficient time for backflush.
- 4 Program the pressure ramp for the column installed between the inlet and the CFT device. After the last analyte elutes or after reaching the last temperature of interest, program a fast ramp (for example, 30 psi/min) with a final pressure of 0.
- 5 Program the pressure ramp for the primary column installed between the CFT device and the detector. The pressure should increase slightly during the backflush duration so that the flow into the detectors remains relatively stable.

If you turned off data acquisition in a data system during backflush, remember to turn it on again at the end of the run.

To backflush using a ramped flow program

In this case, the backflush occurs as part of the run, so the detectors continue to collect data. During the backflush, you may wish to turn off data collection in the data system.

CAUTION

To avoid damage to an MSD, Agilent strongly recommends setting up backflush as a post run event, not as part of a ramped column program. If you still choose to backflush as part of a run, be very careful that the flow into the MSD does not exceed the limits of the vacuum pump.

- 1 Verify that all columns are properly configured.
- 2 Enter all method parameters for the analysis: sampler parameters, inlet parameters, oven temperature profile, detector flows and temperatures, and so forth.
- 3 Program the oven for the backflush.
 - Include any temperature profile needed for backflush.
 - Set the total run time to include sufficient time for backflush.
- 4 Program the flow ramp for the column installed between the inlet and the CFT device. After the last analyte elutes or after reaching the last temperature of interest, program a fast ramp with a final flow that is negative.
- 5 Program the flow ramp for the primary column installed between the CFT device and the detector. Typically hold at the method's final value for the backflush duration.

If you turned off data acquisition in a data system during backflush, remember to turn it on again at the end of the run.

Backflushing using a switching valve

Backflushing is done using a column switching valve controlled by the Run Table. See [“Run Time Programming”](#) on page 14.

The valve is plumbed as follows:

- **Position 1** Carrier gas flows through the column to the detector. This is the normal flow path.
- **Position 2** Carrier gas flows through the column toward the inlet, removing components on the column through the inlet vent line.

The Run Table contains commands to perform these actions:

- After the last peak of interest appears, switch the valve to **Position 2**. Higher boiling peaks are discarded through the inlet vent.
- At the same time, turn data acquisition off.

- At the end of the backflush period (determined experimentally), switch the valve to **Position 1** and turn data acquisition on. The system is now ready for the next run.

Nickel Catalyst Tube

About the nickel catalyst tube

The Nickel Catalyst Tube accessory, G2747A, is used for trace analysis of CO and CO₂ with a flame ionization detector. The gas sample is separated on the column and passed over a heated catalyst in the presence of hydrogen, which converts the CO and CO₂ peaks to CH₄.

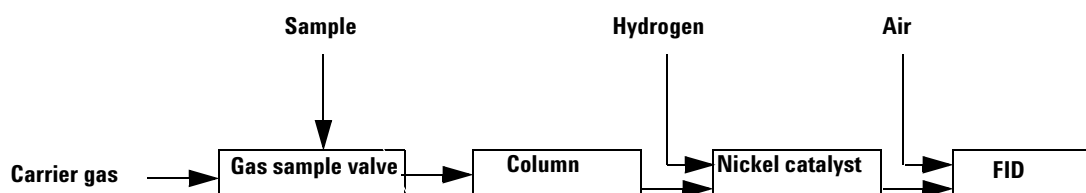

Nickel catalyst gas flows

For a standard FID installation:

Table 62 Gas flows for a standard FID

Gas	Flow rate, mL/min
Carrier (helium)	30
FID hydrogen	30 (see Caution)
FID air	400

Table 63 Gas flows for a TCD/FID series installation

Gas	Flow rate, mL/min
Carrier (helium)	30
TCD switching flow	25
FID hydrogen	45 (see Caution)
FID air	500

CAUTION

Hydrogen flow is pressure-controlled, where an FID provides a known resistance. The nickel catalyst tube increases flow resistance, so that the calibration is no longer valid. You must measure hydrogen flow with a bubble or similar meter.

The nickel catalyst can be damaged by exposure to air.

Setting temperatures for the nickel catalyst tube

The nickel catalyst tube is usually mounted in the back inlet position and controlled by the back inlet temperature setpoint. For most analyses, set these temperatures:

- Nickel catalyst tube—375 °C
- FID—400 °C

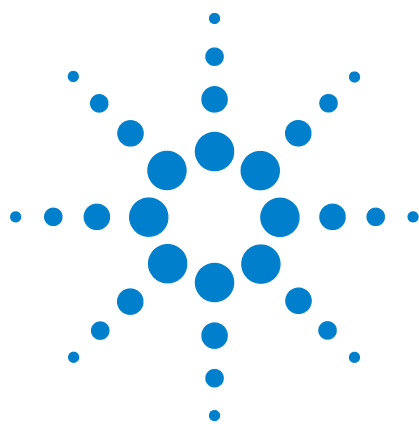

10 Detectors

About Makeup Gas [298](#)

About the FID [299](#)

About the TCD [304](#)

About the uECD [312](#)

About the NPD [319](#)

About the FPD [331](#)

About Makeup Gas

Most detectors use a makeup gas to increase the flow rate through the detector body. This sweeps peaks out of the detector quickly, avoiding mixing of components and loss of resolution. This is particularly important with capillary columns because the column flow rates are so small.

The makeup gas line of your detector parameter list changes depending on your instrument configuration.

If you have an inlet with the *column not defined*, the makeup flow is constant. If you are operating with *column defined*, you have a choice of two makeup gas modes.

Constant makeup This mode provides a constant flow of makeup gas to the detector.

Column + makeup = constant This mode provides a variable flow of makeup gas to the detector. As column flow increases or decreases, the makeup flow changes to provide a constant combined flow to the detector. If you choose this option, enter a value under **Combined flow**. The **Combined flow** line always displays the same value, while the **Makeup** line changes as the actual makeup flow changes.

To change the makeup gas flow mode

- 1 Press **[Front Det]** or **[Back Det]**.
- 2 Scroll to **Mode**. Press **[Mode/Type]**.
- 3 Scroll to the correct mode and press **[Enter]**.

About the FID

The FID passes sample and carrier gas from the column through a hydrogen-air flame. The hydrogen-air flame alone creates few ions, but burning an organic compound increases the number of ions produced. A polarizing voltage attracts these ions to a collector located near the flame. The current produced is proportional to the amount of sample being burned. This current is sensed by an electrometer, converted to digital form, and sent to an output device.

The FID uses three supply gases (hydrogen, makeup gas, and air) and two supply lines. Air flows through one supply line, while hydrogen mixed with the makeup gas flows through the other. All three supply gases use:

- A filter frit to protect the flow path and limit the flow rate
- A proportional valve to control the pressure
- A pressure sensor and restrictor to control the valve

The hydrogen and makeup mix outside the flow module and enter the detector at the base of the jet. Air enters above the jet.

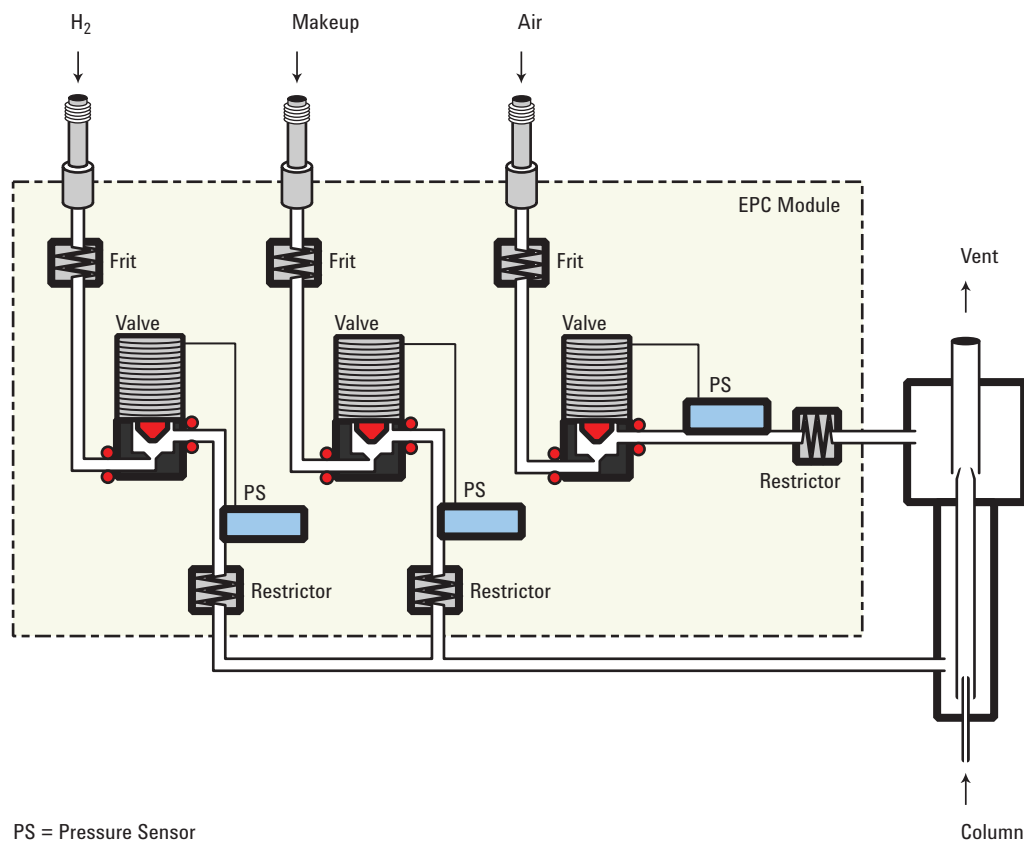

Table 64 Properties of the FID

Property	Value/Comment
Dynamic range	1×10^7
Sensitivity	10 to 100 picograms of an organic compound dependent on the molecular structure.
Selectivity	Responds to all organic compounds (C-H bonds) except those which do not burn or ionize in the hydrogen-air flame. There is little or no response for H ₂ O, CO ₂ , CO, N ₂ , O ₂ , CS ₂ or inert gases. Formaldehyde and heavily halogenated compounds give minimal response.

How FID units are displayed in Agilent data systems and on the GC

The GC displays the FID signal in picoamperes (pA). The following table lists how different data systems convert the display units to reporting units.

Table 65 Unit conversions

Data system	Height units	LSV (height units)	Area units	Noise (ASTM) [‡]
Agilent data system	1 pA	1.3×10^{-4} pA	1 pA-sec	0.038 pA
SIGRange [†] 0	1×10^{-4} pA	1.3×10^{-4} pA	1×10^{-4} pA	0.038 pA
SIGRange 5	3.2×10^{-3} pA	4.2×10^{-3} pA	3.2×10^{-3} pA	0.038 pA
Analog 1V [‡]	1.25×10^{-4} pA	device dependent	1.25×10^{-4} pA	0.038 pA

* Noise is recommended maximum when determining MDL.

† SIGRange used with 3393 and 3396 integrators.

‡ Analog 1V is an approximate value.

To light the FID flame

Press [**Front Det**] or [**Back Det**], scroll to **Flame**, then press [**On/Yes**].

To extinguish the FID flame

Press [**Front Det**] or [**Back Det**], scroll to **Flame**, then press [**Off/No**].

FID automatic reignition (Lit offset)

Lit offset is the expected minimum difference between the FID output with the flame lit and the output with the flame off. The GC checks this value during runs and when loading a method.

During a run, if the output falls below the **Lit offset** value, the FID will attempt to reignite three times. If after the third attempt the output does not increase by at least this value, the detector shuts down all functions except temperature and makeup gas flow.

When loading a method that includes a **Flame On** setting, the GC performs a similar check. If the detector output is less than the **Lit offset**, it will attempt reignition after reaching method setpoints.

The default setting for **Lit offset** is 2.0 picoamps. This is a good working value for all but very clean gases and systems. You may want to lower this setpoint if the detector attempts to reignite when the flame is still on, thus producing a shutdown.

To change **Lit offset**:

- 1 Press [**Config**][**Front Det**] or [**Config**][**Back Det**].
- 2 Scroll to **Lit offset**.
- 3 Enter the new value and press [**Enter**].

Recommended starting conditions for new FID methods

See [Table 66](#) for guidelines and rules to select initial detector settings for new methods.

Table 66 Recommended starting conditions

Combustible gas mix	Make sure that the final hydrogen-to-air ratio is between 8% and 12%
Detector temperature	Set to 20 °C above the highest oven temperature, depending on the column type. A temperature of 300 °C provides a good starting point and easier ignition, and minimizes water condensation. The GC will not attempt to ignite the flame at a temperature <150 °C.
Carrier gas flow (hydrogen, helium, nitrogen)	
Packed columns	Suggest 10 to 60 mL/min
Capillary columns	Suggest 1 to 5 mL/min

Table 66 Recommended starting conditions (continued)

Detector gases	Flow range mL/min	Suggested flow mL/min
Standard installation		
Column plus capillary makeup	10 to 60	30
Hydrogen	24 to 60	30
Air	200 to 600	400
With Nickel Catalyst Accessory: Standard installation		
Column plus capillary makeup	10 to 60	30
Hydrogen	24 to 60	30*
Air	200 to 600	400
With Nickel Catalyst Accessory: TCD to FID series installation		
Column plus capillary makeup	10 to 60	30
TCD switching flow		25
Hydrogen	24 to 60	45*
Air	200 to 600	450

* Detector hydrogen is pressure controlled, where the detector provides a known resistance. If using a nickel catalyst tube, the resistance changes, and the flow rates displayed by the GC will not be accurate. Measure the actual hydrogen flow using a flow meter at the detector vent, with all other flows turned off.

Use nitrogen makeup gas (instead of helium) for greater sensitivity.

Setting parameters for FID

WARNING

Verify that a column is installed or the FID column fitting is plugged before turning on the air or hydrogen. An explosion may occur if air and hydrogen are allowed to leak into the oven.

To set the FID parameters:

- 1 Verify:
 - Makeup gas is configured
 - Installed jet type is correct for column type
- 2 Press **[Front Det]** or **[Back Det]**.

- 3 Set the detector temperature. The temperature must be greater than 150 °C for the flame to light.
- 4 Set the hydrogen flow rate, if desired, and press [**Off/No**].
- 5 Change the air flow rate, if desired, and press [**Off/No**].
- 6 If using a packed column, set the FID makeup gas to **0.0/Off**.
- 7 If using a defined capillary column, set the makeup gas flow or combined column plus makeup gas flow.
- 8 Scroll to **Flame** and press [**On/Yes**]. This turns on the air and hydrogen and initiates the ignition sequence. The signal typically increases to 5 to 20 pA after ignition.

Verify that the flame is lit by holding a cold, shiny surface, such as a mirror or chrome-plated wrench, over the collector exit. Steady condensation indicates that the flame is lit.

About the TCD

The TCD compares the thermal conductivities of two gas flows—pure carrier gas (the reference gas) and carrier gas plus sample components (the column effluent).

This detector contains a filament that is heated electrically so that it is hotter than the detector body. The filament temperature is held constant while alternate streams of reference gas and column effluent pass over it. When a sample component appears in the effluent, the power required to keep the filament temperature constant changes. The two gas streams are switched over the filament five times per second (hence the ticking sound) and the power differences are measured and recorded.

When helium (or hydrogen) is used as carrier gas, the sample causes the thermal conductivity to fall. If nitrogen is used, the thermal conductivity usually goes up because most things are more conductive than nitrogen.

Because the TCD does not destroy the sample during the detection process, this detector can be connected in series to a flame ionization detector or other detector.

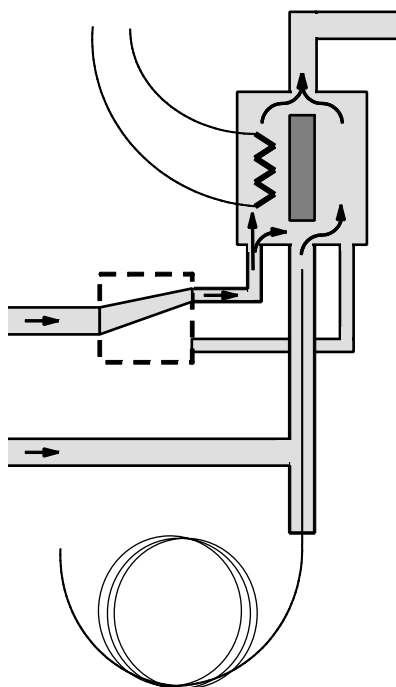

Column effluent is forced away from the filament. TCD measures reference gas.

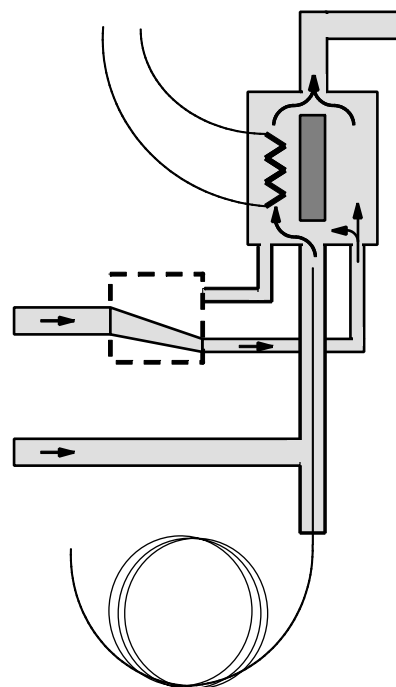

Column effluent is forced toward the filament. TCD measures peaks (if present).

TCD pneumatics

This is the pneumatics design of the TCD.

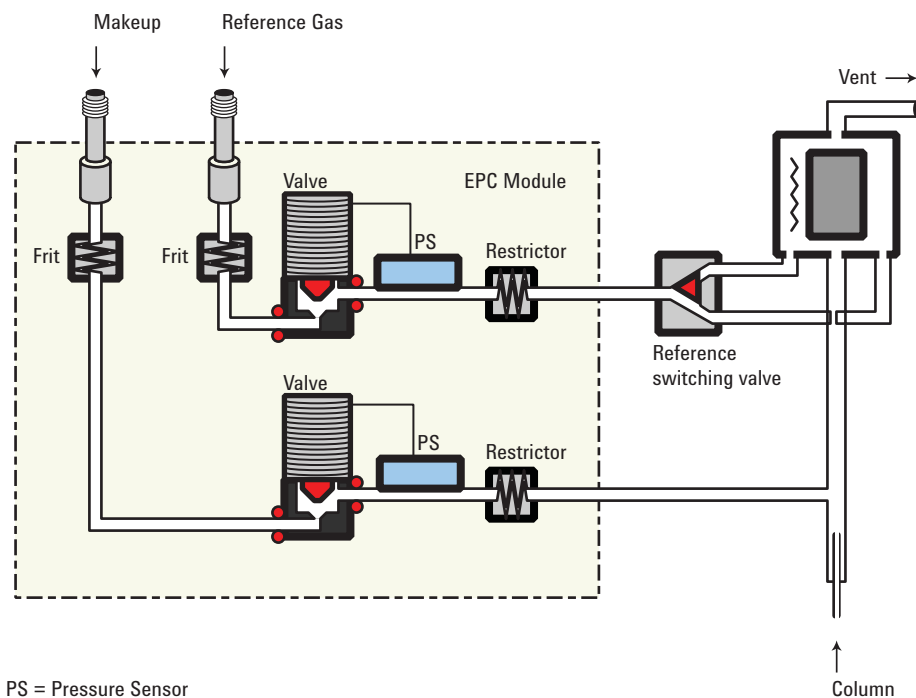

TCD carrier, reference, and makeup gas

Reference and makeup gas must be the same as the carrier gas, and the gas type must be specified in both the inlet and detector parameter lists.

When using packed columns, we recommend a small makeup gas flow (2 to 3 mL/min) to get the best peak shapes.

Use the next figure to select a value for reference gas flow for either capillary or packed columns. Any ratio within ± 0.25 of that in the figure is suitable.

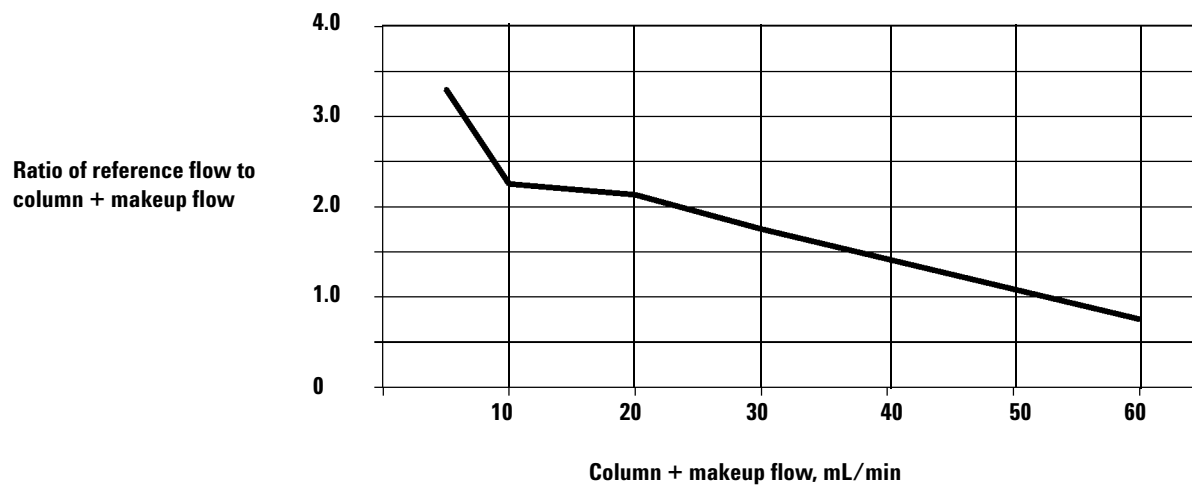

TCD gas pressures

Choose a flow, find a pressure, set source pressure 10 psi (70 kPa) higher.

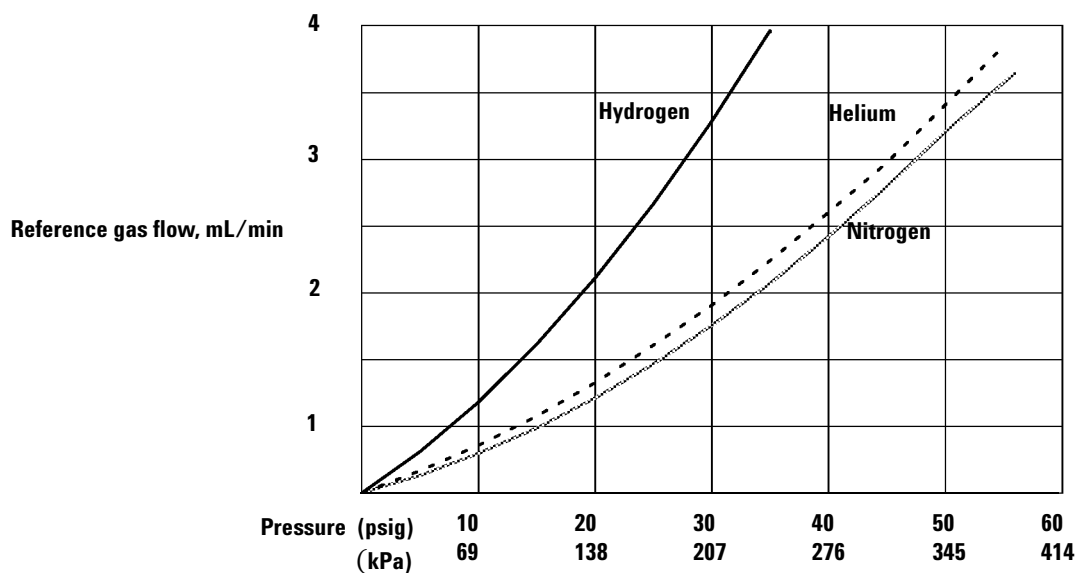

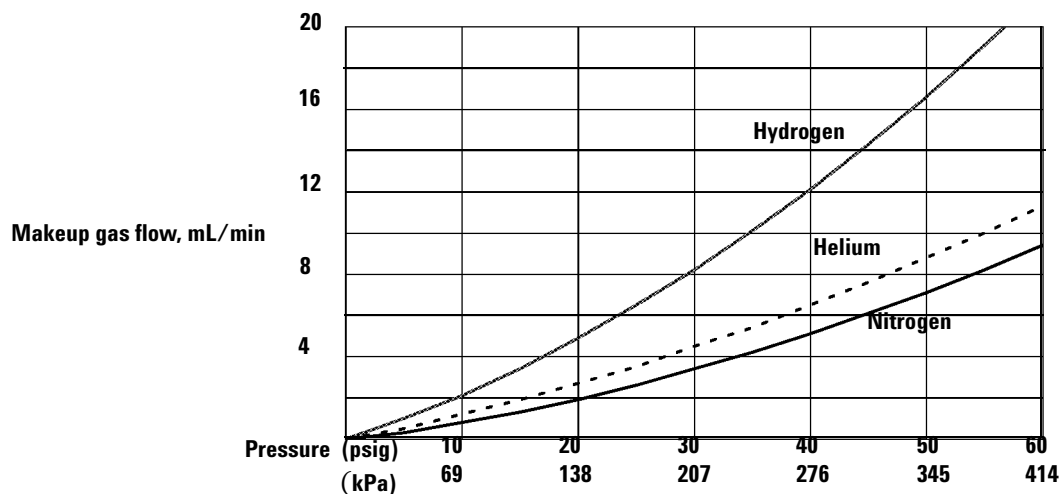

Selecting reference and makeup flows for the TCD

Table 67 Recommended flow rates and temperatures

Gas type	Flow range
Carrier gas (hydrogen, helium, nitrogen)	Packed, 10 to 60 mL/min Capillary, 1 to 5 mL/min
Reference (same gas type as carrier)	15 to 60 mL/min See the figures to select a value.
Capillary makeup (same gas type as carrier)	5 to 15 mL/min—capillary columns 2 to 3 mL/min—packed columns
Detector temperature	
<150 °C, cannot turn on filament	
Detector temperature should be 30 °C to 50 °C greater than highest oven ramp temperature.	

Sample components with higher thermal conductivities than the carrier gas produce negative peaks. For example, helium or hydrogen form a negative peak with nitrogen or argon- methane as the carrier gas.

Chemically active compounds reduce TCD filament life

The tungsten-rhenium TCD filament has been chemically passivated to protect against oxygen damage. However, chemically active compounds such as acids and halogenated

compounds may attack the filament. The immediate symptom is a permanent change in detector sensitivity due to a change in filament resistance.

If possible, such compounds should be avoided. If this is not possible, the filament may have to be replaced frequently.

Changing the TCD polarity during a run

Negative polarity On inverts the peak so the integrator or ChemStation can measure it. **Negative polarity** can be a run table entry; see “[Run Time Programming](#)” on page 14.

Detecting hydrogen with the TCD using helium carrier gas

Hydrogen is the only element with thermal conductivity greater than helium, and mixtures of small amounts of hydrogen (<20%) in helium at moderate temperatures exhibit thermal conductivities less than either component alone. If you are analyzing for hydrogen with helium carrier gas, a hydrogen peak may appear as positive, negative, or as a split peak.

There are two solutions to this problem:

- Use nitrogen or argon-methane as carrier gas. This eliminates problems inherent with using helium as carrier, but causes reduced sensitivity to components other than hydrogen.
- Operate the detector at higher temperatures—from 200 °C to 300 °C.

You can find the correct detector operating temperature by analyzing a known range of hydrogen concentrations, increasing the operating temperature until the hydrogen peak exhibits normal shape and is always in the same direction (negative relative to normal response to air or propane) regardless of concentration. This temperature also ensures high sensitivity and linear dynamic range.

Because hydrogen peaks are negative, you must turn negative polarity on at appropriate times so the peak appears positive.

Setting parameters for the TCD

- 1 Press [**Front Det**] or [**Back Det**].
- 2 Set the detector temperature. Do not set higher than the maximum temperature allowed for the column because part of the column passes through the heated block and into the cell.

- 3 Verify that makeup gas type is the same as that plumbed to your instrument (next to **Makeup** line in the parameter list). Change the gas type, if necessary.
- 4 Set the reference gas flow rate.
- 5 If you are using packed columns, turn off the makeup gas (or proceed to step 6 and enter 2 to 3 mL/min, see “TCD carrier, reference, and makeup gas” on page 306) and proceed to step 7
- 6 If you are using *capillary columns*, choose a flow mode and set the makeup gas flow or combined flow.
- 7 Turn on the filament. Allow about 30 minutes for thermal stabilization. A longer period may be needed for the highest sensitivity.
- 8 If necessary, turn **Negative polarity [On/Yes]** to invert negative- going peaks. When a sample contains components giving both positive- and negative- going peaks, **Negative polarity** can be switched on and off during a run as a timetable event.

Example: Packed mode (packed and large capillary columns)

Column flow is 15 to 60 mL/min. Set the reference flow to 1.5 times the sum of column flow + makeup flow.

Makeup gas is recommended with all capillary columns. It allows the column to be inserted all the way into the detector and withdrawn 1 mm. If makeup is not used, the column must be no more than 3 mm above the ferrule. Minimum makeup flow is 1 mL/min.

1/8-inch stainless steel column If column flow is 30 mL/min, set the reference flow to $30 \times 1.5 = 45$ mL/min. Total detector flow is $30 + 45 = 75$ mL/min.

10 m \times 0.53 mm column If column flow is 15 mL/min and makeup flow = 2 mL/min, set the reference flow to $1.5 \times (15 + 2) = 25.5$ mL/min. Total detector flow is $17 + 25.5 = 42.5$ mL/min.

Example: Capillary mode (small capillary columns)

If combined column plus makeup flow is between 5 and 10 mL/min, set the reference flow at 3 \times the combined flow. For a combined flow between 10 and 15 mL/min, use a multiplier of 2. This will bring the TCD within 25% of the maximum response. For further optimization, adjust the reference flow.

2 m × 0.2 mm capillary column If column flow is 0.75 mL/min, the makeup must be at least 4.25 mL/min. Set it = 5. Reference flow will then be $3 \times 5.75 = 17.25$ mL/min. Total detector flow = $5.75 + 17.25 = 22.5$ mL/min.

25 m × 0.32 mm capillary column If column flow = 10 mL/min, set makeup low to minimize sample dilution. Set it = 2 mL/min. Reference flow will then be $12 \times 2 = 24$ mL/min. Total detector flow = $12 + 24 = 36$ mL/min.

About the uECD

The micro-cell detector (uECD) contains a cell plated with ^{63}Ni , a radioactive isotope. The ^{63}Ni releases β particles that collide with carrier gas molecules to produce low-energy electrons—each β particle produces approximately 100 electrons. The free electrons produce a small current—called the *reference* or *standing current*—that is collected and measured in a pulsed circuit.

When a sample component molecule comes into contact with the free electrons, the electrons may be captured by the sample molecules to create negatively charged ions. The voltage across the cell electrodes is pulsed to collect the remaining free electrons while the heavier ions are relatively unaffected and swept out the vent with the carrier gas flow.

Cell current is measured and compared to a reference current. The pulse rate is adjusted to maintain a constant cell current. The more uncaptured electrons, the lower the pulse frequency required to match the reference current. When a component that captures electrons passes through the cell, the pulse rate rises. This pulse rate is converted to a voltage and recorded.

uECD safety and regulatory information

The ^{63}Ni isotope

The radioactive isotope used in the cell is ^{63}Ni . It is plated onto the inner surface of the cell body and is solid at temperatures used in chromatography. Some other properties are listed below.

Table 68 Properties of ^{63}Ni

Property	Value
Half-life:	101.1 years
Emission:	65.87 keV max., beta radiation
Melting point:	1453 °C
Dimensions of the active part of the uECD:	Inside diameter: 6 mm Height: 4.2 mm
Total activity (uECD cell):	555 MBq (15 millicuries) maximum

ECD licenses

Customers in the United States can purchase a uECD under either a General License or a Specific License. Customers outside the United States should contact their local Agilent sales office for information.

Specific License Specific License uECDs require you to obtain a Materials License from the Nuclear Regulatory Commission (NRC) or the local state agency, permitting you to possess the amount and kind of radioisotope used in the detector. You can typically ship, sell, or transfer the ECD to other Specific Licensees. If the license permits, you may also open the uECD for cleaning.

General License General License uECDs do not require a Materials License. You become a General Licensee automatically when you purchase a uECD directly from Agilent Technologies. Some states may require that you register the uECD with a state agency.

Certain restrictions apply to General Licenses:

- 1 Owners may not open the uECD cell.
- 2 Owners shall not modify the cell in any manner.
- 3 Owners shall not use any solvent, including water, to internally clean the cell.
- 4 Owners shall not interfere with or attempt to defeat the overheat circuitry that may be supplied with the uECD.
- 5 Owners shall not transfer the uECD to another person or another location except as described in the applicable Regulations.
- 6 Owners must perform a radioactive leak test at least every 6 months.
- 7 Owners must maintain records as required by your local Agency (the NRC or, in certain states, a state agency).
- 8 Owners must notify the Agency in case of incidents or failures that might lead to a hazardous condition.

Additional information is available in the publication “Information for General Licensees,” part no. 5961-5664.

uECD warnings

Although beta particles at this energy level have little penetrating power—the surface layer of the skin or a few sheets of paper will stop most of them—they may be hazardous if the

isotope is ingested or inhaled. For this reason the cell must be handled with care: Radioactive leak tests must be performed at the required intervals, the inlet and outlet fittings must be capped when the detector is not in use, corrosive chemicals must not be introduced into the detector, and the effluent from the detector must be vented outside the laboratory environment.

WARNING

Materials that may react with the ^{63}Ni source, either to form volatile products or to cause physical degradation of the plated film, must be avoided. These materials include oxidizing compounds, acids, wet halogens, wet nitric acid, ammonium hydroxide, hydrogen sulfide, PCBs, and carbon monoxide. This list is not exhaustive but indicates the kinds of compounds that may cause damage to ^{63}Ni detectors.

WARNING

In the *extremely unlikely* event that *both* the oven and the detector heated zone should go into thermal runaway (maximum, uncontrolled heating in excess of 400 °C) at the *same time*, and that the detector remains exposed to this condition for *more than 12 hours*, take the following steps:

- After turning off the main power and allowing the instrument to cool, cap the detector inlet and exhaust vent openings. Wear disposable plastic gloves and observe normal laboratory safety precautions.
- Return the cell for exchange, following directions included with the License Verification Form (part no. 19233-90750).
- Include a letter stating the condition of abuse.

It is unlikely, even in this very unusual situation, that radioactive material will escape the cell. However, permanent damage to the ^{63}Ni plating within the cell is possible, and therefore, the cell must be returned for exchange.

WARNING

Do not use solvents to clean the uECD.

WARNING

You may not open the uECD cell unless authorized to do so by your local nuclear regulatory agency. Do not disturb the four socket-head bolts. These hold the cell halves together. Removing or disturbing them is a violation of the terms of the General License and could create a safety hazard.

Safety precautions when handling uECDs

- Never eat, drink, or smoke when handling uECDs.
- Always wear safety glasses when working with or near open uECDs.
- Wear protective clothing such as laboratory jackets, safety glasses, and gloves, and follow good laboratory practices. Wash hands thoroughly with a mild non-abrasive cleaner after handling uECDs.
- Cap the inlet and outlet fittings when the uECD is not in use.
- Connect the uECD exhaust vent to a fume hood or vent it to the outside. See the latest revision of title 10, Code of Federal Regulations, part 20, (including appendix B) or the applicable State regulation. For other countries, consult with the appropriate agency for equivalent requirements.

Agilent Technologies recommends a vent line inside diameter of 6 mm (1/4 inch) or greater. With a line of this diameter, the length is not critical.

uECD gas flows

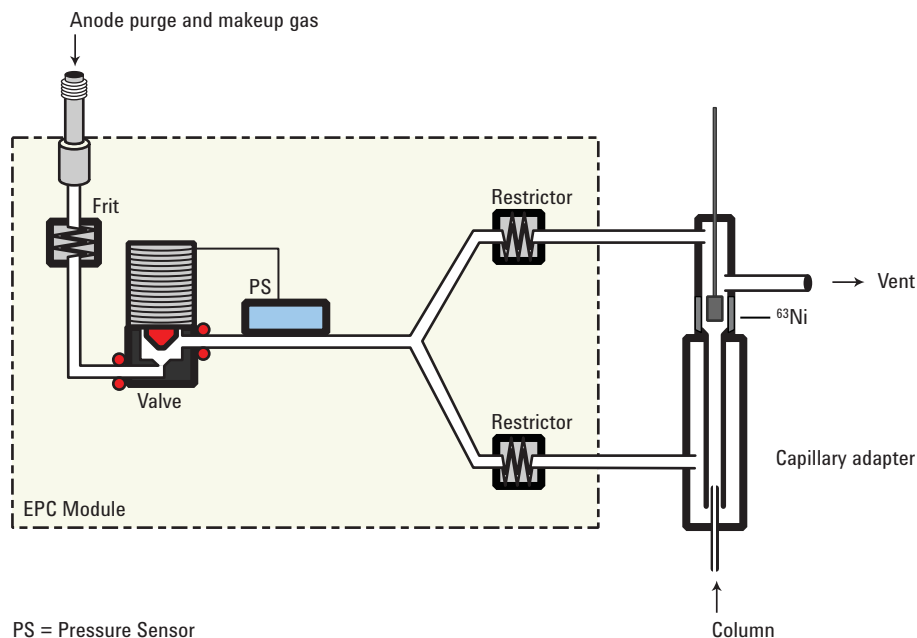

uECD linearity

The uECD response factor versus concentration curve is linear for four orders of magnitude or more (linear dynamic range = 10^4 or higher) for a broad range of compounds. You should still run a calibration curve on your samples to find the limits of the linear range for your materials.

uECD detector gas

The uECD operates with either nitrogen or argon/methane as the makeup and anode gas. Purity is critical; gases must exceed 99.9995% purity.

Because of the high detector sensitivity, carrier and makeup gas must be dry and oxygen-free. Moisture, chemical, and oxygen traps in good condition should be installed in carrier and makeup gas supply lines. Do not use plastic (including Teflon) tubing, plastic-bodied traps, or O-ring seals.

uECD temperature

To prevent peak tailing and to keep the cell clean, the detector temperature should be set higher than the highest oven temperature used—the setpoint should be based on the elution

temperature of the last compound. If you operate at excessively high temperatures, your results will not necessarily improve and you may increase sample and column decomposition.

uECD analog output

If you intend to use the analog output from the uECD, you must set the output Range to 10.

- 1 Press [**Analog Out 1**] or [**Analog Out 2**].
- 2 Scroll to **Range**.
- 3 Type **10** and press [**Enter**].

Recommended starting conditions for new uECD methods

Use the following information when selecting temperatures and flows. Maximum source pressure must not exceed 100 psi. Use the maximum source pressure to achieve maximum makeup flow rate.

Table 69 Starting values

Gas	Recommended flow range
Carrier gas	
Packed columns (nitrogen or argon-methane)	30 to 60 mL/min
Capillary columns (hydrogen, nitrogen, or argon-methane)	0.1 to 20 mL/min, depending on diameter
Capillary makeup (nitrogen or argon-methane)	10 to 150 mL/min (30 to 60 mL/min typical)
Temperature	
250 °C to 400 °C	
Detector temperature is typically set 25 °C greater than the highest oven ramp temperature.	

uECD makeup gas notes

If the carrier gas type is different from the makeup gas type, the makeup gas flow rate must be at least three times the carrier gas flow rate.

uECD sensitivity can be increased by reducing the makeup gas flow rate.

uECD chromatographic speed (for fast peaks) can be increased by increasing the makeup gas flow rate.

uECD temperature programming

The uECD is flow sensitive. If you are using temperature programming, in which the column flow resistance changes with temperature, set up the instrument as follows:

- Set the carrier gas in the **Constant flow** mode. Set detector makeup gas to **Constant makeup**.
- If you choose to work in the constant pressure mode, the makeup gas should be set in the **Column +makeup=constant** mode.

Setting parameters for the uECD

Verify that your detector gases are connected, a column is properly installed, and the system is free of leaks. Set the oven temperature and the inlet temperature and flow. Make sure your carrier gas type is the same as that plumbed to your GC.

- 1 Press **[Front Det]** or **[Back Det]**.
- 2 Set the detector temperature. To keep the uECD cell clean, this temperature must be higher than the oven temperature.
- 3 Verify that the makeup gas type is the same as that plumbed to your instrument. The gas type is in parentheses next to the **Makeup** line on the parameter list. Change the gas type, if necessary.
- 4 Enter a value for the makeup gas flow.
 - If you are using *packed columns*, turn off the makeup gas.
 - If your *capillary column* is *defined*, choose a flow mode and set the makeup or combined gas flow.
 - If your *capillary column* is *not defined*, only constant makeup flow is available. Enter a makeup gas flow.

About the NPD

New NPD features and changes

The NPD firmware in this GC (A.01.08 or higher) is considerably different from that in earlier versions and from the 6890 firmware. Major changes are:

- Equilibration time parameter has been removed.
- Adjust Offset feature has been changed.
- Auto Adjust on/off has been added.
- Dry Mode has been added.
- Bloss/ceramic bead selector has been added.

We strongly recommend that you allow the firmware to perform Auto Adjust and set the Bead Voltage.

NPD software requirements

This discussion assumes that the following firmware/software is installed:

Table 70 Software requirements

Product	Software/firmware revision
7890A GC	A.01.08 or higher
Agilent GC ChemStation	B.04.01 or higher
Agilent MSD ChemStation	G1701EA or higher
Agilent EZ Chrom Elite	3.3.2 or higher

Software/firmware with numbers less than shown in the table can cause reduced bead lifetime. See the Agilent web site (www.agilent.com) for firmware and software updates.

NPD flows and general information

The NPD passes sample and carrier through a hydrogen/air plasma. A heated ceramic or glass source, called the bead, is just above the jet. The low hydrogen/air ratio cannot sustain a flame, minimizing hydrocarbon ionization, while the alkali ions on the bead surface facilitate ionization of nitrogen- or phosphorus- organic compounds.

The output current is proportional to the number of ions collected. It is sensed by an electrometer, converted to digital form, and sent to an output device.

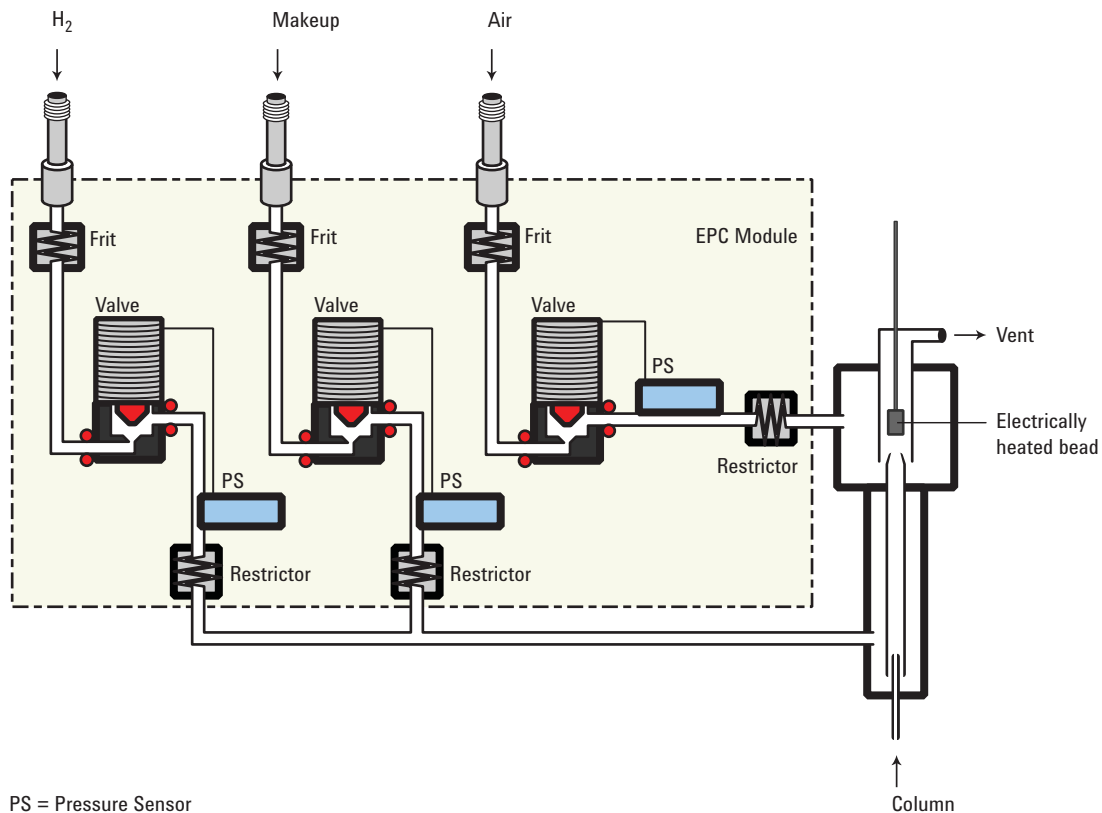

NPD flow, temperature, and bead recommendations

Table 71 General operating values

Gas or Setting	Recommendation
Carrier gas (helium, hydrogen, nitrogen)	Capillary, choose optimum flow based on column dimensions.
Detector gases	
Hydrogen	Ceramic bead 2 to 5 mL/min Blos bead 1 to 3 mL/min
Air	Ceramic bead 60 mL/min Blos bead 120 mL/min

Table 71 General operating values (continued)

Gas or Setting	Recommendation
Capillary makeup (<i>helium, nitrogen</i>)	Ceramic bead Nitrogen: 5 to 10 mL/min Helium: less than 5 mL/min Bios bead 1 to 20 mL/min
Temperature	
Default is 250 °C; operating range is 150 °C to 400 °C.	
<ul style="list-style-type: none"> • <150 °C, the Adjust offset process will not start. • 325 to 335 °C is recommended. • Detector temperature should be greater than the highest oven temperature. With higher detector temperatures, less bead heating voltage is required. 	
Adjust offset	
Default is 30 pA, suggested operating range is 20 to 40 pA, and allowable range is 0 to 99.9 pA.	
<ul style="list-style-type: none"> • ≥ 50 pA increases sensitivity but reduces bead life. • Lower settings reduce sensitivity and increase bead life, but settings too low will result in solvent quenching. • The time required for Adjust offset depends on the bead type and condition. 	
Bead voltage	
Ceramic bead. Range is 0 to 4.095 V.	
Bios bead. Range is 0.5 to 1.1 V.	
<ul style="list-style-type: none"> • Use Auto Adjust On, Dry Bead, and let the GC set the Bead Voltage for you. 	

Source gas pressures

Choose a flow, find a pressure, and set source pressure 10 psi (70 kPa) higher.

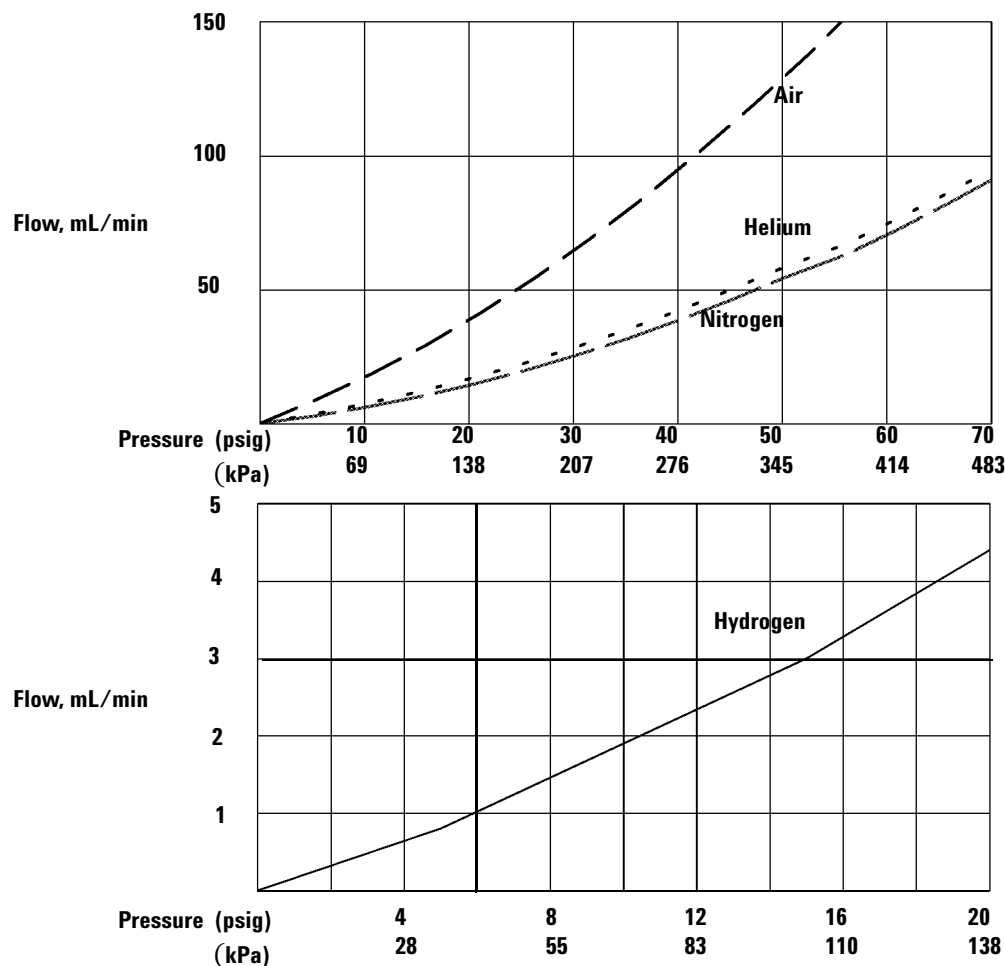

Temperature programming

The NPD is flow sensitive. If you are using temperature programming, in which the column flow resistance changes with temperature, set up the instrument as follows:

- Set the carrier gas in the **Constant flow** mode. Set detector makeup gas to **Constant makeup**.
- If you choose to work in the constant pressure mode, the makeup gas should be set in the **Column +makeup=constant** mode.

NPD required gas purity

Because of its high sensitivity, the NPD requires very pure (at least 99.9995%) gases. We strongly recommend that moisture and organics traps be used on the carrier gas and all detector

gases, including the detector hydrogen, air, and makeup gases. Do not use plastic (including Teflon) tubing, plastic-bodied traps, or O-ring seals.

Setting parameters for the NPD

Before operating the NPD, make sure that detector gases are connected, a column is installed, and the system is free of leaks. Set the oven temperature, inlet temperature, and column flow.

WARNING

Make sure that a column is installed or the NPD column fitting is plugged before turning on the air or hydrogen. An explosion may occur if air and hydrogen are allowed to leak into the oven.

- 1 Select the bead (white ceramic, black ceramic, Blos).
- 2 Select the jet.
- 3 Install bead and jet as required. (See the Maintenance Manual for details.)
- 4 Press **[Config][Front Det]** or **[Config][Back Det]**.
- 5 If you are using makeup gas, verify that the configured makeup gas type is the same as that plumbed to your instrument. Change the gas type, if necessary. Nitrogen is recommended.
- 6 If the displayed **Bead Type** is incorrect, set the Bead Type using the **[Mode/Type]** key.
- 7 Set **Auto Adjust** (**On** recommended).
- 8 Set **Dry Bead** (**On** recommended).
- 9 Press **[Front Det]** or **[Back Det]**.
- 10 Set the detector temperature. The recommended range is 325 to 335 °C.
- 11 Enter a hydrogen flow (3.0 mL/min is recommended). Turn the flow **On**.
- 12 Enter an air flow (60 is recommended for ceramic beads, 120 for Blos beads). Turn the flow **On**.
 - a If you are using *packed columns*, turn off makeup gas and proceed to step 13.
 - b If your *capillary column* is *defined*, choose a flow mode and set the makeup gas flow. For a column in the constant

flow mode, choose **Constant makeup**. For a column in the constant pressure mode, choose **Column +makeup=constant**.

- c If your column is *not defined*, enter a makeup gas flow. Only constant flow is available.

13 Monitor the offset adjustment process.

- a If **Auto Adjust** is **On**, the adjust offset process starts automatically when the detector reaches setpoint. If **Auto Adjust** is **Off**, the Bead Voltage will gradually go to the last setpoint after the bead reaches setpoint temperature and the Dry Bead time has elapsed.
- b If you need to set a new target offset, enter an **Adjust offset** value. Adjust offset starts when the detector reaches setpoint.
- c If **Auto Adjust** is **Off**, you can manually start the Adjust offset process by scrolling to **Adjust offset**, then pressing [**On/Yes**].
- d If your standard operating procedures require that you set the bead voltage directly, see “[Setting NPD bead voltage manually \(optional\)](#)” on page 329.

Selecting an NPD bead type

Three beads are available:

Table 72 NPD beads

Bead type	Part number	Advantages	Disadvantages
White ceramic	G1534-60570	Standard	Phosphorus tails
Black ceramic	5183-2007	Durable, no phosphorus tailing	Lower nitrogen sensitivity, about 40%
Blos bead	G3434-60806	Moisture resistant, long life	



Ceramic beads



Blos bead

Changing from a ceramic bead to a Bloss bead

CAUTION

The Bloss bead is more delicate than the ceramic beads, and may be distorted during shipping. Before installing a Bloss bead, verify that it is centered and adjust it if necessary.

When you turn the NPD off, the GC remembers the bead voltage used and applies that voltage when the detector is turned back on. If you have changed from a ceramic bead to a Bloss bead, this voltage will be too high and may damage the new bead.

To avoid this, reduce the voltage to the ceramic bead to 0.5 V before turning the detector off. When it restarts, the lower voltage will be applied.

Selecting an NPD jet

Open the oven door and locate the column connection fitting at the base of the detector. It will look like either a capillary optimized fitting or an adaptable fitting.

Capillary optimized fitting



Adaptable fitting

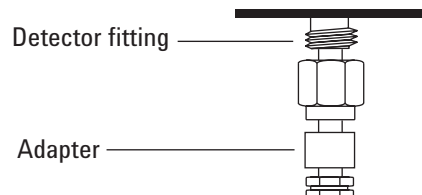

- If you have an application that tends to clog the jet, select a jet with a wider tip id.
- When using packed columns in high column- bleed applications, the jet tends to clog with silicon dioxide.

For capillary optimized fittings, select one of the following from [Table 73](#).

Table 73 Jets for capillary optimized fittings

Figure 3 ID	Jet type	Part number	Jet tip id	Length
1	Capillary with extended jet (recommended)	G1534-80580	0.29 mm (0.011 inch)	51.5 mm
2	Capillary	G1531-80560	0.29 mm (0.011 inch)	43 mm
3	High-temperature	G1531-80620	0.47 mm (0.018 inch)	43 mm



Figure 1 Capillary optimized NPD jets

For the adjustable NPD, select one of the following from [Table 74](#).

Table 74 Jets for adaptable fittings

Figure 4 ID	Jet type	Part number	Jet tip id	Length
1	Capillary with extended jet (recommended)	G1534-80590	0.29 mm (0.11 inch)	70.5 mm
2	Capillary	19244-80560	0.29 mm (0.011 inch)	61.5 mm
3	Capillary, high-temperature	19244-80620	0.47 mm (0.018 inch)	61.5 mm
4	Packed	18710-20119	0.46 mm (0.018 inch)	63.6 mm



Figure 2 Adaptable NPD jets

To configure the NPD

In addition to the **Ignore Ready** and **Makeup gas** type, the NPD requires the following configuration settings. Scroll to each and enable/disable using **[On/Yes]** or **[Off/No]**.

Auto Adjust Bead Recommended **On**. When On, the automatic adjust offset process starts when the bead reaches the temperature setpoint after having been turned off or cooled below 150 °C. Auto adjust starts after **Dry Bead** hold time, if enabled. Auto Adjust Bead uses the adjust offset feature to protect the bead—especially new beads—by making sure that the desired offset is obtained with the lowest possible bead voltage. When Off, the bead voltage will rise as soon as the Dry Bead time elapses, or as soon as the temperature setpoint is reached if Dry Bead is off.

Dry Bead Recommended **On**. When On, the bead temperature holds at 150 °C for 5 minutes before continuing to the setpoint. This allows any condensation to evaporate and be swept out of the detector.

Blos Bead If using a Blos bead, set to **On**. For ceramic beads, set to **Off**. The Blos Bead On setting restricts the allowable bead voltage to the range appropriate for this bead.

Maximum Bead Voltage Display only. Shows the current maximum bead voltage for the configured bead type (4.095 V for ceramic beads, 1.1 V for the Blos bead).

Automatically adjusting NPD bead voltage

Agilent recommends using the Adjust offset feature to automatically determine the lowest bead voltage needed to give the desired response.

When the detector is turned on, the temperature rises at a controlled rate.

- If **Dry Bead** is **On**, temperature holds at 150 °C for 5 minutes to drive off moisture, then continues to the setpoint.
- If **Dry Bead** is **Off**, the temperature rises directly to the setpoint.

When the temperature reaches the setpoint, the Bead Voltage gradually rises until it produces the desired output.

Adjust offset

When you enter a value here, or press [**On/Yes**] to use the stored value, detector gas flows turn on, the bead heats, and the bead voltage adjusts until **Output** is stable and equal to the entered value. There are five stages of **Adjust offset**.

Detector off When the detector is off, **Adjust offset** and **Bead voltage** are **Off** and initial **Output** is displayed.

Detector on—detector temperature less than 150 °C. When you enter an **Adjust offset** value or press **[On]**, detector gases turn on and the display blinks the **Temp not ready** message.

Detector on—waiting for oven and/or detector to reach temperature setpoint and equilibrium. If the oven or detector is not at setpoint, the display continues to blink the **Temp not ready** message.

Detector on—Dry Bead On If **Dry Bead** is **On**, the temperature rise holds at 150 °C for 5 minutes to remove moisture, then continues to the setpoint.

Detector on—during adjust offset. When the detector and oven temperatures reach setpoint and equilibrate, the **Adjust offset** process begins. The bead voltage is slowly increased until the output is close to the **Adjust offset** value. The display blinks **Detector Slewing**.

Detector on and ready. When the **Adjust offset** value is reached, the **Adjust offset** line reads **Done** and displays the offset target setpoint. Your detector is on and ready. The display shows the actual **Bead voltage**.

Setting NPD adjust offset on the clock table

You can use the **Clock table** feature to begin **Adjust offset** at a specified time.

Aborting NPD adjust offset

Press **[Delete]** with the cursor on the **Adjust offset** line. This cancels the adjustment without turning off the detector gases and bead voltage.

Extending the NPD bead life

These actions, together with the automated heatup and adjust procedures, can extend ceramic bead life considerably.

- Use the lowest practical **Adjust offset** value. This will result in a lower Bead Voltage during operation.
- Run clean samples.
- Turn the bead off when not in use.

- Keep the detector temperature high (320 to 335 °C).
- Turn the hydrogen flow off during solvent peaks and between runs.

Turning hydrogen off during a solvent peak

When using the NPD, the baseline shifts after a solvent peak and can take some time to stabilize, especially with chlorinated solvents. To minimize this effect, turn off the hydrogen flow during the solvent peak and turn it back on after the solvent elutes. With this technique, the baseline recovers to its original value in less than 30 seconds. This also extends the life of the bead. The hydrogen can be turned on and off automatically as part of a Run Table. See “[Run Time Programming](#)” on page 14.

Turning hydrogen off between runs

To extend bead life, turn off the hydrogen flow between runs. Leave all other flows and the detector temperature on. Turn on the hydrogen flow for the next run; the bead will ignite almost immediately. The process can be automated with Run Table entries.

Turning off the detector

CAUTION

If you turn **Adjust offset [Off]** at any time, the bead voltage, hydrogen, and air flows all turn off.

Setting the initial bead voltage for new beads

Before you turn on the bead for the first time, manually set its voltage to a safe value so that the new bead is not destroyed.

- 1 Make sure **Adjust Offset** is turned **Off**.
- 2 After the temperature stabilizes at setpoint, set the initial Bead Voltage, depending on bead type:
 - Bloss bead: 0.0 V to 0.5 V
 - Ceramic bead (white or black): 0.0 V to 2.0 V

Setting NPD bead voltage manually (optional)

Bead voltage shows the voltage used to heat the bead. It can be a value derived from the **Adjust offset** value, or can be entered as a setpoint. Entering a setpoint causes the voltage to change at 13 mV/second until it reaches the setpoint provided that

- the detector is at the temperature setpoint
- temperature is at least 150 °C
- gas flows are on
- **Dry Bead** time, if **On**, has elapsed

Bead voltage is also useful for small adjustments between runs. If you observe a baseline drift, you can enter a small, one-time change to compensate for the drift.

If you are not using the recommended Adjust offset process, note that large voltage jumps reduce bead life. Use increments no greater than 0.05 V, spaced 10 seconds apart, until you reach the desired offset.

New beads

After a new bead reaches the initial voltage, begin to increase the voltage value in 0.05 V increments until the bead ignites. Wait about 10 seconds between each voltage adjustment. Monitor the detector output. When the bead ignites, the output will rise suddenly, then decrease towards a more stable value. It is best to allow the NPD to remain in this state without further adjustment for about 24 hours. Then you may adjust the bead voltage in small increments (0.05 to 0.1 V) until reaching the desired offset. With a clean environment, clean gas supplies, and low bleed column, a typical offset may decrease 6- 12 pA during a 24 hour period.

Typical voltages for new ceramic beads range from 2.5 to 3.7 volts. Higher values reduce bead life.

Typical voltages for new Blos beads range from 0.5 to 1.0 V.

About the FPD

The sample burns in a hydrogen- rich flame, where some species are reduced and excited. The gas flow moves the excited species to a cooler emission zone above the flame where they decay and emit light. A narrow bandpass filter selects light unique to one species, while a shield prevents intense carbon emission from reaching the photomultiplier tube (PMT).

The light strikes a photosensitive surface in the PMT where a light photon knocks loose an electron. The electron is amplified inside the PMT for an overall gain of up to a million.

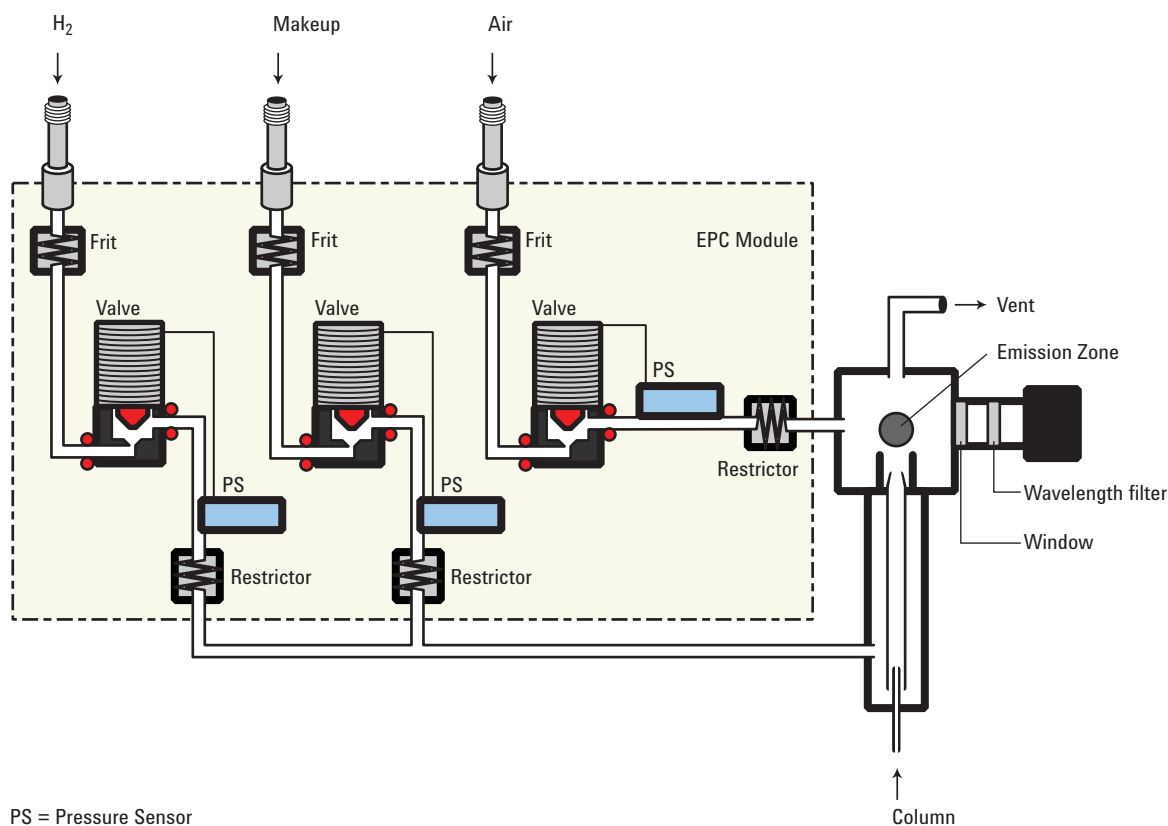

The current from the PMT is amplified and digitized by the FPD electronics board. The signal is available either as a digital signal on the communications output or as a voltage signal on the analog output.

The FPD should not be stored at temperatures above 50 °C, based on the original manufacturer's specifications for the PMT.

FPD linearity

Several mechanisms produce sulfur emission. The excited species is diatomic, so that emission intensity is approximately proportional to the square of the sulfur atom concentration.

The excited species in the phosphorus mode is monatomic, leading to a linear relationship between emission intensity and atom concentration.

FPD Lit Offset

The default **Lit Offset** is 2.0 pA.

Starting Up and Shutting Down the FPD

The FPD creates a great deal of water vapor when the flame is on. This could condense in the vent tube on top of the detector and drop onto the flame, possibly extinguishing it. To avoid this, turn the heaters on, wait 20 minutes for the vent to heat up, and then ignite the flame. Water vapor will now make it over the top of the vent tube before condensing.

For similar reasons, extinguish the flame before turning the heaters off.

FPD photomultiplier protection

The PMT is extremely sensitive to light. Always turn the **PMT voltage** off (which turns off the high voltage to the PMT) before removing the PMT housing or opening the emissions chamber. Failing to do this can destroy the PMT.

Even with the **PMT voltage** off, protect the PMT from room light. Cap the housing when removed, place it end down to exclude light, reduce room light level before exposing the PMT, and so on. A brief exposure (always with the **PMT voltage** turned off) will not damage it but prolonged exposure will cause a gradual loss of sensitivity.

FPD optical filters

The filters are marked on the edge with the transmission wavelength. Each filter has a small arrow on its side which must point toward the PMT when installed.

The sulfur filter is silvery on both sides and transmits at 393 nanometers.

The phosphorus filter is yellow/green and transmits at 525 nanometers.

Inlet liners for use with the FPD

Compounds containing sulfur may adsorb on an inlet liner and degrade the GC's performance. Use deactivated, clean liners or a cool on-column inlet, which injects directly onto the column.

For best results with splitless injection, use liner 5181-3316.

FPD temperature considerations

The minimum detector temperature to prevent water condensation is 120 °C. We recommend a temperature that is 25 °C higher than the highest column temperature, but no higher than 250 °C.

FPD gas purity

High-purity gases have a lower sulfur content. Standard purity gases have a higher sulfur content which impairs sulfur detection in the compound being studied. Instrument or Chromatographic grades work well.

Agilent recommends using helium carrier, nitrogen makeup gas, and air with 99.9995% purity or better. Use carbon, oxygen, and moisture traps. Select traps to remove sulfur compounds from detector air and nitrogen gases. A helium getter is also recommended.

FPD gas flows

Table 75 gives the flows for the maximum sensitivity FPD flame, which is hydrogen-rich and oxygen-poor.

Table 75 Recommended flows

	Sulfur mode flows, mL/min	Phosphorus mode flows, mL/min
Carrier (hydrogen, helium, nitrogen, argon)		
Packed columns	10 to 60	10 to 60
Capillary columns	1 to 5	1 to 5
Detector gases		
Hydrogen	50	75

Table 75 Recommended flows (continued)

	Sulfur mode flows, mL/min	Phosphorus mode flows, mL/min
Air	60	100
Carrier + makeup	60	60

Helium, either as carrier or makeup gas, may cool the detector gases below the ignition temperature. We recommend using nitrogen rather than helium.

Lighting the FPD flame

Before trying to light the flame, have the detector at operating temperature. Removing the condensate tubing may help, but be sure to replace it before making runs.

It is difficult to light the flame with the flows shown in [Table 75](#), particularly in the sulfur mode. If the flame will not light with the sulfur mode flows shown, change to the phosphorus mode flows. After ignition, gradually reduce the flows to the sulfur values. Some experimentation will be needed.

When either of the flame ignition methods in this section is used, the FPD automatically performs this sequence:

- 1 Turns all detector gases—air, hydrogen, makeup—off. Carrier remains on.
- 2 Sets air flow to 200 mL/min.
- 3 Turns the glow plug ignitor on.
- 4 Ramps the hydrogen flow from 10 to 70 mL/min.
- 5 Resets the air flow to the air flow setpoint.
- 6 Resets the hydrogen flow to the hydrogen flow setpoint.
- 7 Turns the makeup gas on.
- 8 Compares the signal change with the **Lit offset** value. If the change is greater than **Lit offset**, declares the flame on (lit). If it is less, declares the flame off (not lit).

For this process to work, there must be enough air pressure to the pneumatics module to provide 200 mL/min flow. We recommend a supply pressure of 90 psi.

Manual ignition

- 1 Press **[Front Det]** or **[Back Det]**.
- 2 Scroll to **Flame**. Press **[On/Yes]**. The flame ignition sequence begins.

Automatic ignition

If the FPD output with the flame on falls below the flame-off output plus the **Lit offset** value, this is interpreted as a flame-out condition. The FPD runs the flame ignition sequence to relight the flame. If this fails, it runs the sequence again. If the second attempt also fails, the detector shuts down all functions except temperature and makeup gas flow.

Setting parameters for the FPD

WARNING

Verify that a column is installed or the FPD fitting is plugged before turning on the air or hydrogen. An explosion may occur if air and hydrogen are allowed to leak into the oven.

- 1 Press **[Front det]** or **[Back det]**.
- 2 Set the detector temperature. It must be greater than 120 °C for the flame to light.
- 3 Change the hydrogen flow rate, if desired. Press **[Off/No]**.
- 4 Change the air flow rate, if desired. Press **[Off/No]**.
- 5 If you are using packed columns, turn off the makeup gas and proceed to step 7.
- 6 If you are using capillary columns:
 - a Verify that makeup gas type is the same as that plumbed to your instrument (next to **Makeup** in the parameter list). Change the gas type, if necessary.
 - b If your capillary column is *defined*, choose a flow mode and set the makeup gas flow or combined flow.
 - c If your capillary column is *not defined*, enter a makeup gas flow. Only constant flow is available.
- 7 Scroll to **Flame** and press **[On/Yes]**. This turns on the air and hydrogen and initiates the ignition sequence.

On ignition, the signal increases. Typical levels are 4 to 40 pA in sulfur mode, 10 to 70 pA in phosphorus mode. Verify that the flame is lit by holding a cold, shiny surface, such as a mirror or chrome-plated wrench, over the vent exit. Steady condensation indicates that the flame is lit.



11 Valves

About Valves	338
The Valve Box	339
Heating the valves	339
Valve temperature programming	339
Configuring an Aux thermal zone	340
Valve Control	341
The valve drivers	341
The internal valve drivers	341
The external valve drivers	342
Valve Types	343
Configuring a Valve	344
Controlling a Valve	345
From the keyboard	345
From the run or clock time tables	345
Simple valve: column selection	345
Gas sampling valve	346
Multiposition stream selection valve with sampling valve	347

About Valves

Valves may be used to alter the usual inlet/column/detector flow path in the GC. Sampling valves can replace the inlet, switching valves can select columns, multiposition valves, used in conjunction with sampling valves, can perform the same functions for sample streams that an ALS performs for liquid samples.

The Valve Box

The GC holds up to four valves in a heated valve box on top of the oven.

The valve box is the preferred location for valves because it is a stable temperature zone, isolated from the column oven.

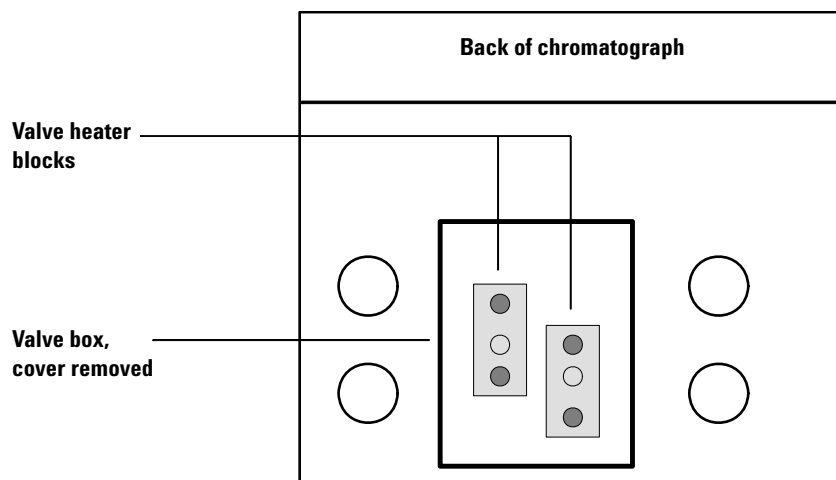

Figure 3 Diagram of valve locations on GC

Valves may also be mounted inside the column oven.

Heating the valves

The valve box contains two heated blocks, each with two valve mounting locations (shaded in [Figure 3](#)). The middle hole on each block is used to pass tubing into the column oven.

If two valves are used, mount them on the same block. This allows them to be heated using only one control channel (**Aux Temp 1** or **Aux Temp 2**, depending on how the heaters are wired). With more than two valves, both channels must be used for heating the two blocks. Set them at the same temperature.

Valve temperature programming

Most valve applications are isothermal; however, you can define three temperature ramps if desired. Press [**Aux Temp #**], then [**1**] or [**2**]. Program this ramp the same as an oven ramp. Refer to [“Setting the oven parameters for ramped temperature”](#) on page 282 for more information.

Configuring an Aux thermal zone

To configure a thermal Aux zone (1 or 2), press [**Config**][**Aux Temp #**], then [**1**] or [**2**]. Press [**Mode/Type**], then select the type of device to be controlled. Press [**Enter**].

Valve Control

Valves can be controlled manually from the keyboard or as part of a clock or run time program. Note that only sampling valves automatically reset at the end of a run. Other valve types remain at the new position until activated again. For other valve types, you must include any desired resets in the program.

The valve drivers

A valve driver is the software and circuitry in the GC that controls a valve or related function. There are eight drivers known as Valve 1 through Valve 8.

Table 76 Valve drivers

Valve number	Type	Volts	Power or current	Use
1, 2, 3, and 4	Current source	24 VDC	13 watts	Pneumatic valve control
5 and 6	Current source	24 VDC	100 mA	Relays and low-power devices
7 and 8	Contact closure	48 VDC or 48 VAC RMS		Control an external current source

The internal valve drivers

Valve drivers 1 through 4 are usually used to control pneumatically operated valves mounted in the valve box. The wiring for these appears at a set of connectors inside the right cover of the GC.

Pneumatically driven valves are controlled by solenoids mounted near the connectors that control the flow of air to the valve actuators.

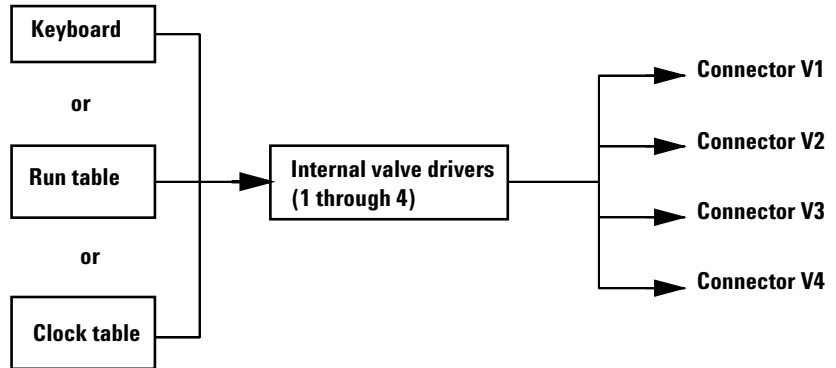

There is no direct relationship between the location of a valve in the valve box and the driver that controls it. This depends on how the solenoids are wired and the actuators are plumbed.

Manual valves must be switch by hand, and are heated or unheated.

The external valve drivers

Valve drivers 5 and 6 control a current that may be used to drive a relay or other low- power device. Valve drivers 7 and 8 switch a current from an external source. Electrical details are in [Table 76](#) on page 341.

These drivers, particularly Valve 7 and 8, may be used to control a motor driven multiposition valve for stream selection.

All four of these drivers appear on the External Event connector on the back of the GC.

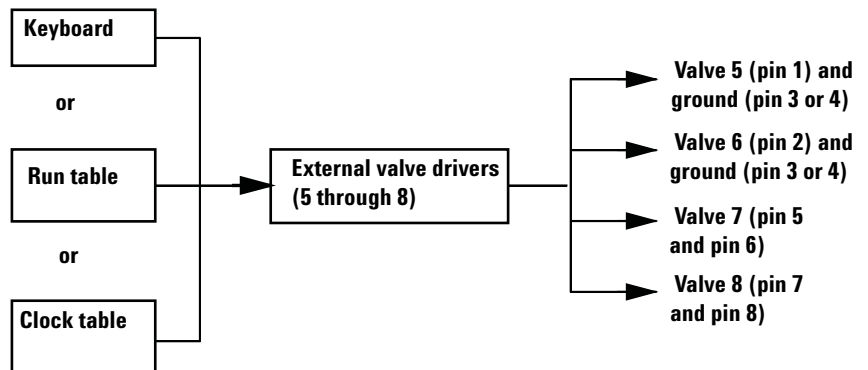

Valve Types

There possible valve types are:

Sampling A two- position (load and inject) valve. In load position, an external sample stream flows through an attached (gas sampling) or internal (liquid sampling) loop and out to waste. In inject position, the filled sampling loop is inserted into the carrier gas stream. When the valve switches from **Load** to **Inject**, it starts a run if one is not already in progress. See the example on [page 346](#).

Switching A two- position valve with four, six, or more ports. These are general- purpose valves used for such tasks as column selection, column isolation, and many others. For an example of valve control, see [page 347](#).

Multiposition Also called a stream selection valve. It is usually used to select one from a number of gas streams and feed it to a sampling valve for analysis. It has a special actuator that advances the valve one position each time it is activated, or it may be motor driven. An example that combines a stream selection valve with a gas sampling valve is on [page 347](#).

Other Could be anything.

Not installed Self- explanatory.

Configuring a Valve

- 1 Press **[Config]**. Scroll to **Valve #**.
- 2 Enter the valve number and press **[Enter]**. The current valve type is displayed.
- 3 To change the valve type, press **[Mode/Type]**, select the new valve type, and press **[Enter]**.

Controlling a Valve

From the keyboard

Valves (except multiposition valves) have two positions controlled by the **[On]** and **[Off]** keys. The keyboard commands for two-position valves are:

[Valve #] <scroll to the valve> **[On]** Rotates valve to one stop and

[Valve #] <scroll to the valve> **[Off]** Rotates valve to the other stop

From the run or clock time tables

The **Valve On** and **Valve Off** commands can be run time or clock time programmed. See [“Run Time Programming”](#) on page 14 and [“Clock Time Programming”](#) on page 17.

If a valve is rotated by a run time program, it is *not* automatically returned to its initial position at the end of the run. You must program this reset operation yourself.

Simple valve: column selection

This is the plumbing for a single valve, configured as a switching valve, that selects one of two columns for analysis. It has no configuration parameters.

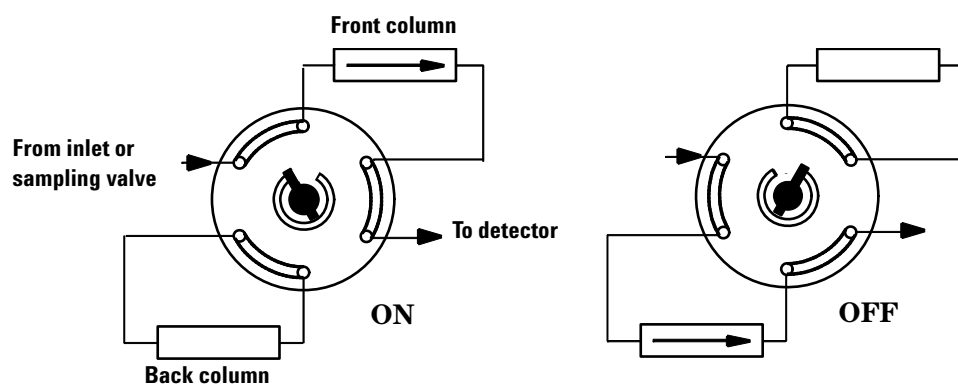

The column is selected by pressing:

[Valve #] <scroll to valve #> **[On]** (for the front column) or **[Off]** (for the back column).

Use a run table entry to ensure that the valve is in the Off state between runs.

Gas sampling valve

If a valve is configured as a gas sampling valve, it starts a run automatically when it is switched to the Inject position. This can be done with a keyboard command or by a subsequence or clock table entry. You may have two gas sampling valves installed.

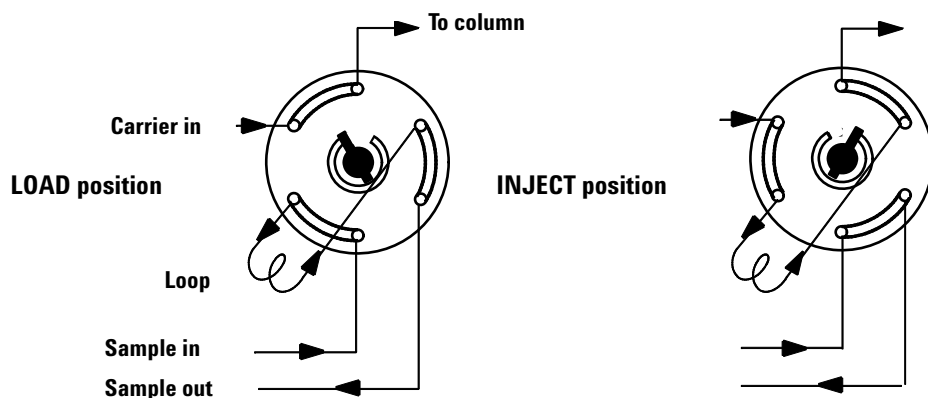

Load position The loop is flushed with a stream of the sample gas. The column is flushed with carrier gas.

Inject position The filled loop is inserted into the carrier gas stream. The sample is flushed onto the column. The run starts automatically.

Carrier gas may be provided by an (optional) auxiliary gas channel. To do this, configure the column and specify an Aux # channel as the inlet. The channel then becomes programmable with four operating modes.

Sampling valves have two positions:

Load position The loop (external for gas sampling, internal for liquid sampling) is flushed with a stream of the sample. The column is flushed with carrier gas.

Inject position The filled loop is inserted into the carrier gas stream. The sample is flushed onto the column. The run starts automatically.

The sampling valve control parameters are:

Load time Time in minutes that the valve remains in the Load position before becoming ready.

Inject time Time in minutes that the valve remains in the Inject position before returning to the Load position.

The sampling valve cycle is:

- 1 The sampling valve rotates to the Load position. **Load time** begins. Valve is not ready.
- 2 **Load time** ends. The valve becomes ready.
- 3 If everything else is ready, the GC becomes ready. If anything is not ready:
 - If you are using Clock Table or sequence control, the GC waits until everything is ready, then executes the valve inject command.
 - If you are not using Clock Table or sequence control, the valve injection can be made at any time from the keyboard.
- 4 The sampling valve rotates (keyboard command or sequence control) to the Inject position. **Inject time** begins. The run begins.
- 5 **Inject time** ends. Return to step 1.

Multiposition stream selection valve with sampling valve

Several manufacturers provide multiposition stream selection valves that can be driven by valve drivers 1 through 4. Only one multiposition valve can be configured.

If a valve is configured as a multiposition valve and has a BCD position output connected to the GC, the valve position can be selected directly.

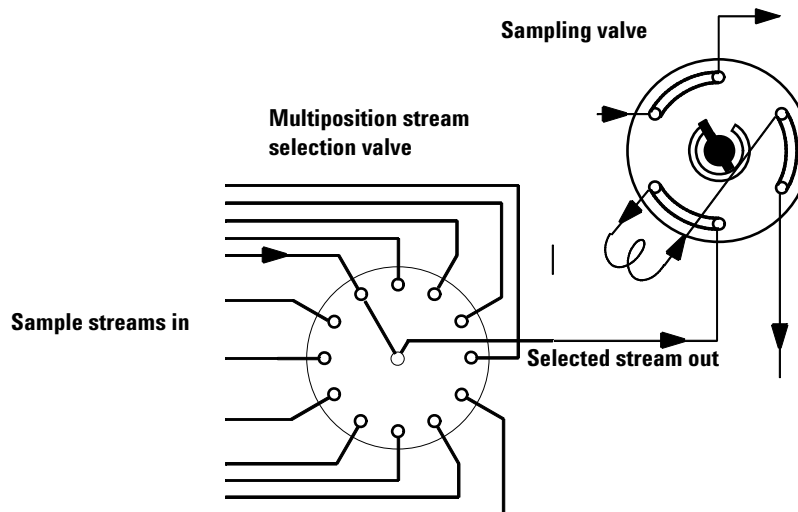

If the GC has one valve configured as a multiposition valve and another configured as a gas or liquid sampling valve, it assumes that they are to be used in series. This “double configuration” can be used to replace an automatic liquid sampler and sample tray in an analytical sequence. The multiposition valve becomes the sample tray; the sampling valve becomes the injector.

Two configuration parameters provide mechanical and electrical compatibility with most multiposition valve actuators.

Switching time In seconds, is a delay between successive actuator movements. It allows time for the actuator mechanism to prepare for the next movement.

Invert BCD Complements the BCD input; 1's become 0's and 0's become 1's. This accommodates coding convention differences among manufacturers.

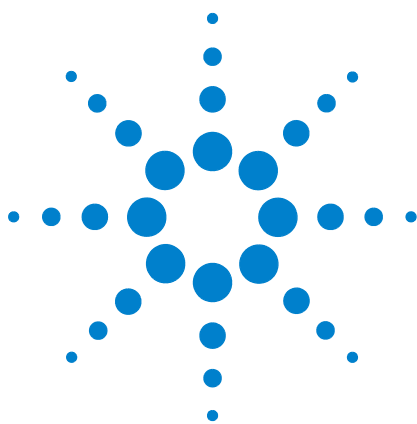

12 7683B Sampler

About the 7683B Sampler	350
Setting Parameters for the ALS	351
Solvent Saver	352
Sample tray setpoints	353
Storing setpoints	353

About the 7683B Sampler

The 7683B Automatic Liquid Sampler (ALS) is controlled by a sequence that specifies what samples are to be analyzed, where the sample vials are located in the sampler tray (if used), what methods are to be used for each sample, and possibly what to do after the last sample to clean out the column. See [“Creating Sequences”](#) on page 111 for more information on sequences.

Hardware

Consult the 7683B for all mechanical details, such as installing/removing the tray, injectors, bar code reader, syringes, and so on. Follow the instructions for the 6890N GC.

Software

The new 7890A parameters are described in this chapter. Follow these instructions for all non-mechanical operations.

Setting Parameters for the ALS

Pressing either of the injector keys allows you to edit injector control setpoints, such as injection volumes, sample and solvent washes, etc.

To edit the injector setpoints:

- 1 Press **[Front Injector]** or **[Back Injector]**.
- 2 Scroll to the desired setpoint.
- 3 Enter a setpoint value, or turn the setpoint On or Off.
- 4 Press **[Mode/Type]** to make selections for syringe size and syringe plunger speed.

Injection volume Sample volume to be injected. Press **[Mode/Type]** to select. The available volumes depend on the syringe size configured.

- The selections represent 2%, 10%, 20%, 30%, 40%, and 50% of syringe size.
- Turn the injection volume Off to disable the injector.

Viscosity delay (0-7 seconds) How long the plunger pauses at the top of the pump and injection strokes. For viscous samples, the pause allows the sample to flow into the vacuum created in the syringe.

Inject Dispense Speed The speed of the syringe plunger during injection. Enables you to reduce the average speed of the plunger. Press **[Mode/Type]** to see the choices. The plunger speed during the pump and waste dispensing does not change.

Sample pumps (0-15) How many times the syringe plunger is moved up and down with the needle in the sample to expel air bubbles and improve reproducibility.

Sample washes (0-15) How many times the syringe is rinsed with sample before the injection. The wash volume is set by the Solvent Saver setting.

Solvent A post washes (0-15) How many times the syringe is washed with solvent A after injection.

Solvent A pre washes (0-15) How many times the syringe is washed with solvent A before the sample washes.

Solvent B post washes (0-15) How many times the syringe is washed with solvent B after any solvent A washes.

Solvent B pre washes (0-15) How many times the syringe is washed with solvent B after any solvent A prewashes and before the sample washes.

Solvent B wash volume The percent of the syringe volume to be used for solvent B washes.

Sample Draw Speed Speed of the syringe plunger when drawing in sample.

Sample Disp Speed Speed of the syringe plunger when dispensing sample.

Solvent Draw Speed Speed of the syringe plunger when drawing in solvent.

Solvent Disp Speed Speed of the syringe plunger when dispensing solvent.

Pre dwell time (0-1) How long, in minutes, the needle remains in the inlet before the injection.

Post dwell time (0-1) How long, in minutes, the needle remains in the inlet after injection.

Sample offset (-2 to 30, Off) Sets variable sampling depth.

Injection Reps (1-99) How many times the injection and analysis should be repeated from each vial.

Injection Delay Time between multiple injections. Availability depends on the inlet type.

Solvent Saver

If you enter a non-zero value for any of the solvent or sample washes, the GC will ask for the wash volume. The default is 80% of the syringe volume. Press **[Mode/Type]** to see the other choices. This function allows you to conserve solvent during the washes.

Sample tray setpoints

The sample tray delivers sample vials to the front and rear injectors according to the defined sequence parameters. There is a separate set of sequence parameters for each injector. The sample tray delivers vials to the front injector before the rear injector. Stored sequences and bar code configurations can be used to tell the sample tray where to deliver and retrieve sample vials.

Enable bar code Turns the bar code reader on or off.

- 1 Press [**Sample tray**] to access the sample tray and bar code reader setpoints.
- 2 Press [**On**] or [**Off**] to enable or disable the tray.
- 3 Press [**On**] or [**Off**] to enable or disable the bar code reader.

Storing setpoints

After setting up injector setpoints, sample tray setpoints and bar code reader configurations, store them as part of a method by following the procedures in [To store a method from the keypad](#). This method becomes a part of the sequence used to run the samples.



13 Cables

About Cables and Back Panel Connectors 356

Back panel connectors 356

Sampler connectors 356

The AUX connector 356

Signal connectors 357

REMOTE connector 357

EVENT connector 357

BCD input connector 357

RS-232 connector 357

LAN connector 357

Using the Remote Start/Stop cable 358

Cable Diagrams 363

Analog cable, general use 363

Remote start/stop cable 363

BCD cable 364

External event cable 365

About Cables and Back Panel Connectors

Some parts of an analysis system are connected to the GC by cables. These cables and the back panel connectors to which they connect are described in this section.

Back panel connectors

These are the connectors on the back panel of the GC:

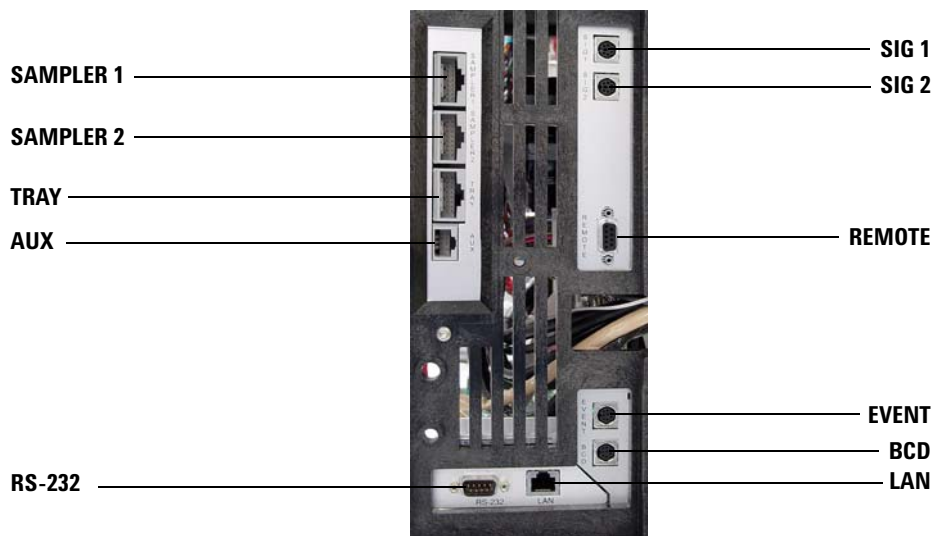

Sampler connectors

If using an ALS, connect to the GC using the following connectors:

SAMPLER 1 An injector, usually the front injector. (For 7693A, the configuration does not matter. For a the 7683, typically configured as **INJ1**.)

SAMPLER 2 A second injector, usually the back injector. (For 7693A, the configuration does not matter. For a the 7683, typically configured as **INJ2**.)

TRAY The sample tray and (optional) barcode reader.

The AUX connector

This connector is reserved for future development.

Signal connectors

SIG1 and **SIG2** are for the two analog output signals.

REMOTE connector

Provides a port to remotely start and stop other instruments. A maximum of 10 instruments can be synchronized using this connector. See [“Using the Remote Start/Stop cable”](#) on page 358 for more detail.

EVENT connector

This connector provides two passive contact closures and two 24- volt outputs for controlling external devices. The outputs are controlled by valve drivers 5 through 8.

BCD input connector

This connector provides two control relays and a BCD input for a stream selection valve.

CAUTION

This connector is similar to the EVENT connector. Plugging a non BCD cable into the BCD connector can damage the GC.

RS-232 connector

This connector is reserved for future development.

LAN connector

Standard Local Area Network connector, for communication with data systems and other devices.

Using the Remote Start/Stop cable

Remote start/stop is used to synchronize two or more instruments. For example, you might connect an integrator and the GC so that the [**Start**]/[**Stop**] buttons on either instrument control both of them. You can synchronize a maximum of ten instruments using Remote cables.

Connecting Agilent products

If connecting two Agilent products with Remote cables, the sending and receiving circuits will be compatible—just plug in both ends of the cable.

Connecting non-Agilent products

If connecting to a non-Agilent product, the following paragraphs contain information you will need to ensure compatibility.

APG Remote signal electrical specifications

The APG signals are a modified open collector type. The signal levels are generally TTL levels (low voltage is logic zero, high voltage is logic one) but the open circuit voltage will be between 2.5 and 3.7 Volts. The typical voltage is 3 Volts. A voltage over 2.2 volts will be interpreted as a high logic state while a voltage below 0.4 volts will be interpreted as a low logic state. These levels provide some margin over the specifications of the devices used.

The pull-up resistance, connected to the open-circuit voltage, is in the range of about 1K ohms to 1.5K ohms. For a logic-low state, for a single device on the bus, the minimum current you must be able to sink is 3.3 milliamps. Since devices are connected in parallel, when you have multiple devices this minimum current must be multiplied by the number of devices attached on the bus. The maximum voltage for a low-input state = 0.4V.

The bus is passively pulled high. Leakage current out of a port must be less than 0.2 milliamps to keep the voltage from being pulled lower than 2.2 volts. Higher leakage current may cause the state to be interpreted as a low.

Over-voltage protection - APG Remote connections are clamped by a zener diode to 5.6 Volts. Exceeding this voltage will damage the circuit (main board).

APG Remote - Suggested drive circuits

A signal on the APG bus may be driven by another APG device or by one of the following circuits:

- A relay, with one side connected to ground, when closed will set a logic- low state.
- An NPN transistor, with the emitter connected to ground and the collector connected to the signal line will set a logic- low state if proper base current is supplied.
- An open- collector logic gate will perform this same function.
- A low- side drive IC will also work, but Darlington- type drivers should be avoided as they will not meet the low- side voltage requirement of less than 0.4V

APG Remote connector

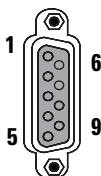

Pin	Function	Logic
1	Digital ground	
2	Prepare	LOW true
3	Start	LOW true (input)
4	Start relay	
5	Start relay	
6	not used	
7	Ready	HIGH true (output)
8	Stop	LOW true
9	not used	

APG Remote signal descriptions

Prepare (Low True) Request to prepare for analysis. Receiver is any module performing pre- analysis activities. For example, shorting pin 2 to ground will put the GC into **Prep Run** state. This is useful for Splitless Mode to prepare the inlet for injection or when using the **Gas Saver**. This function is not needed by Agilent autosampler systems.

Ready (High True) If The Ready Line is high (> 2.2 VDC) then the system is ready for next analysis. Receiver is any sequence controller.

Start (Low True) Request to start run/timetable. Receiver is any module performing runtime- controlled activities. The 7890 GC requires a pulse duration of at least 500 micro- seconds to sense a start from an external device.

Start Relay (Contact Closure) A 120 millisecond contact closure – used as an isolated output to start another device that is not compatible or connected with APG Remote pin 3.

Stop (Low True) Request to reach system ready state as soon as possible (for example, stop run, abort or finish, and stop injection). Receiver is any module performing runtime- controlled activities. Normally this line is not connected, if the GC oven program is used to control the method **Stop** time.

APG Remote timing diagram

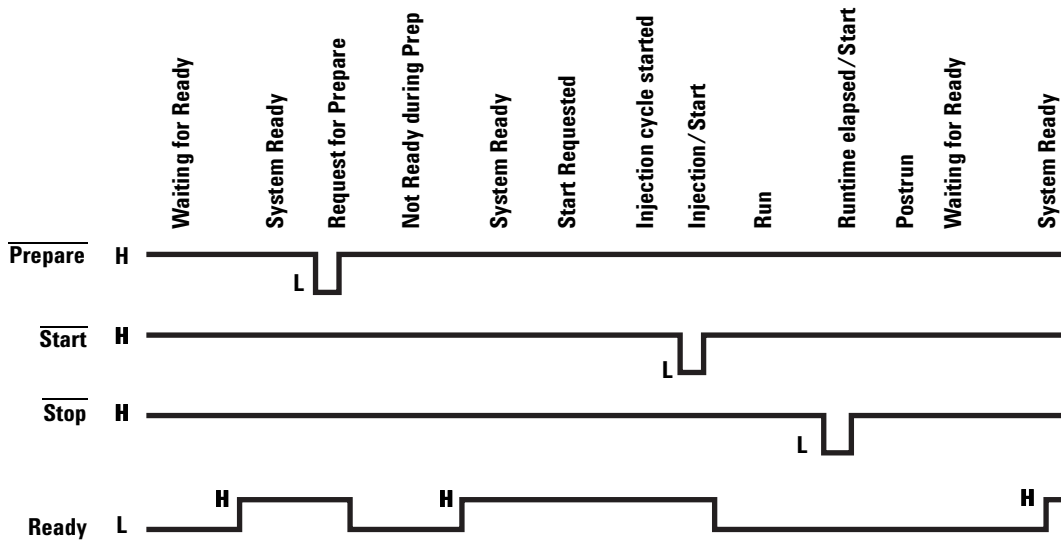

Connecting Cables

Connect a GC to an Agilent data system computer using LAN communications using a LAN cable. See [Figure 4](#) below.

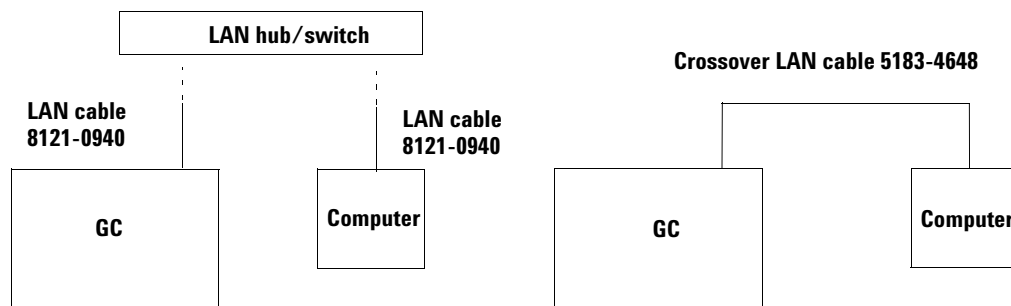

Figure 4 Connecting the GC and computer with a hub/switch (shown at left) or a crossover cable (shown at right).

Table 77 Typical IP addresses for an isolated LAN

	GC	Computer
IP address	10.1.1.101	10.1.1.100
Subnet mask	255.255.255.0	255.255.255.0

A single communications LAN cable is supplied with the GC. The hub and other cables must be ordered separately, if needed. See [Table 77](#) and [Table 78](#) for cabling requirements for other configurations.

Table 78 Cabling requirements

7890A GC connected to:	Required Cable(s)	Part number
7693A Automatic Liquid Sampler	Injector cable or tray cable	G4514-60610
7683 Automatic Liquid Sampler	Injector cable is integral Tray cable	G2614-60610
G1289B/G1290B Headspace Sampler	Remote, 9-pin male/6-pin connector	G1530-60930
7695 Purge and Trap Sampler	Remote, 25-pin male/9-pin male	G1500-60820

Table 78 Cabling requirements (continued)

7890A GC connected to:	Required Cable(s)	Part number
CTC automatic sampler	Remote,	
3395B/3396C Integrator	Remote, 9 pin/15 pin Analog, 2 m, 6 pin	03396-61010 G1530-60570
Non-Agilent Integrator	General purpose analog signal cable 2 m, 6 pin	G1530-60560
Mass Selective Detector	Remote, 2-m, 9-pin male/9-pin male	G1530-60930
Non-Agilent data system	General use remote, 9-pin male/spade lugs (various lengths)	35900-60670 (2 m), 35900-60920 (5 m), 35900-60930 (0.5 m)
Non-Agilent instrument, unspecified	External event, 8 pin/spade lugs	G1530-60590
Stream selection valves Gas sampling valves	See documentation accompanying the valve	
LAN	Cable, networking CAT 5, 25 feet	8121-0940
	Cable, LAN, crossover	5183-4648

Table 79 Cabling for other instruments in a 7890A system

Instrument 1	Instrument 2	Type of cable	Part no.
Modem	PC	Modem, 9-pin female/9-pin male, or Modem, 9-pin female/25-pin male	G1530-61120, or 24540-80012
Mass Selective Detector	Purge & Trap or Headspace sampler	Splitter ("Y") cable for remote, 1 male and 2 female connectors	G1530-61200
		Splitter ("H") cable for APG remote, 2 male and 2 female connectors	35900-60800

Cable Diagrams

Analog cable, general use

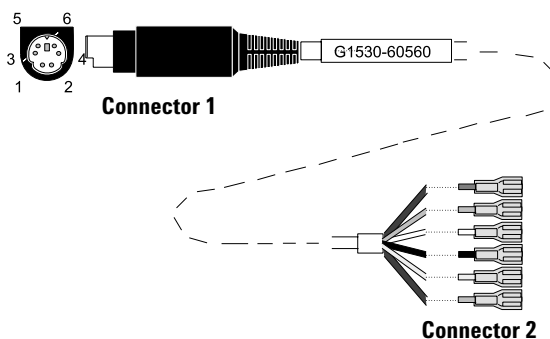

The pin assignments for the general use analog out cable are listed in [Table 80](#).

Table 80 Analog cable, general use, output connections

Connector 1	Connector 2, wire color	Signal
1	Brown or violet	Not used
2	White	0 to 1 V, 0 to 10 V (-)
3	Red	Not used
4	Black	1 V (+)
6	Blue	10 V (+)
Shell	Orange	Ground

Remote start/stop cable

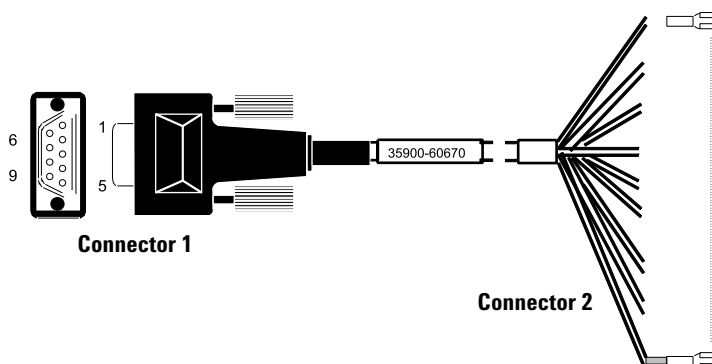

The pin assignments for the remote start/stop cable are listed in [Table 81](#).

Table 81 Remote start/stop cable connections

Connector 1, 9-pin male	Connector 2, wire color	Signal
1	Black	Digital ground
2	White	Prepare (low tone)
3	Red	Start (low tone)
4	Green	Start relay (closed during start)
5	Brown	Start relay (closed during start)
6	Blue	Open circuit
7	Orange	Ready (high true input)
8	Yellow	Stop (low tone)
9	Violet	Open circuit

BCD cable

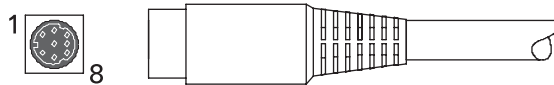

The BCD connector has eight passive inputs that sense total binary-coded decimal levels. The pin assignments for this connector are listed in [Table 82](#).

Table 82 BCD input connections

Pin	Function	Maximum rating
1	Relay	48 V AC/DC, 250 mA
2	Relay	48 V AC/DC, 250 mA
3	LS digit 0	
4	LS digit 1	
5	LS digit 2	
6	LS digit 3	
7	MS digit 0	
8	Ground	
Shield	Chassis ground	

External event cable

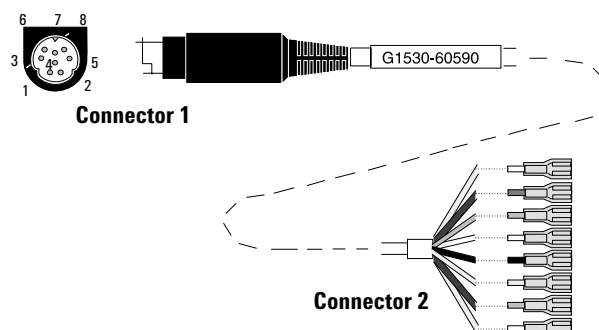

Two passive relay contact closures and two 24-volt control outputs are provided. Devices connected to the passive contact closures must be connected to their own power sources.

The pin assignments for this cable are listed in [Table 83](#).

Table 83 External events cable

Connector 1 pin	Signal name	Maximum rating	Connector 2, wire color	Controlled by valve #
24 volts output				
1	24 V output 1	75 mA	Yellow	5
2	24 V output 1	75 mA	Black	6
3	Ground		Red	
4	Ground		White	
Relay contact closures (normally open)				
5	Closure 1	48 V AC/DC, 250 mA	Orange	7
6	Closure 1		Green	7
7	Closure 2	48 V AC/DC, 250 mA	Brown or violet	8
8	Closure 2		Blue	8



14 GC Output Signals

About Signals	368
Signal Types	369
Value	369
Analog Signals	371
Analog zero	371
Analog range	371
Analog data rates	372
Selecting fast peaks (analog output)	373
Digital Signals	374
Digital zero	374
Baseline level shifts	374
Agilent data systems	375
Column Compensation	378
Creating a column compensation profile	379
Making a run using analog output column compensation	379
Plotting a stored column compensation profile	380
Test Plot	381

About Signals

Signal is the GC output to a data handling device, analog or digital. It can be a detector output or the output from flow, temperature, or pressure sensors. Two signal output channels are provided.

Signal output can be either analog or digital, depending on your data handling device. Analog output is available at either of two speeds, suitable to peaks with minimum widths of 0.004 minutes (fast data rate) or 0.01 minutes (normal rate). Analog output ranges are 0 to 1 V, 0 to 10 V, and 0 to 1 mV.

Digital output rates are set by your Agilent data system, such as ChemStation or EZChrom.

Signal Types

When assigning detector signals, use the **[Mode/Type]** key and choose from the Signal Type parameter list, or press a key or combination of keys.

[Front], **[Back]**, **[-]**, and **[Column Comp]** will work, alone or in combination. For example, press **[Back]** for back detector or **[Back] [-] [Front]** for back detector minus front detector. The menu choices for signal subtraction (**Front - Back** and **Back - Front**) only appear if the front and back detectors are of the same type.

The nondetector signals are test plot, thermal, pneumatic, and diagnostic. Access them by pressing **[Mode/Type]**. Diagnostic signals are for use by your service representative and are not described in detail here.

Signal type can be programmed as a run time event.

Value

Value on the signal parameter list is the same as **Output** on the detector parameter list if your signal type is **Front** or **Back**. If you are subtracting one signal from another (as in **Front - Back**), the signal **Value** will be the difference. You cannot enter a setpoint for **Value**.

A conversion factor may be involved when interpreting **Value**—for example, one FID unit is one picoamp; one uECD unit is 1 Hz. The units for detector and other signals are listed below.

Table 84 Signal conversions

Signal type	1 display unit is equivalent to:
Detector:	
FID, NPD	1.0 pA (1.0×10^{-12} A)
FPD	150 pA (150×10^{-12} A)
TCD	25 mV (2.5×10^{-5} V)
μECD	1 Hz
Analog input board (use to connect the GC to non-Agilent detector)	15 μV
Nondetector:	
Thermal	1 °C

Table 84 Signal conversions (continued)

Signal type	1 display unit is equivalent to:
Pneumatic:	
Flow	1 mL/min
Pressure	1 pressure unit (psi, bar, or kPa)
Diagnostic	Mixed, some unscaled

Analog Signals

If you use an analog recorder, you may need to adjust the signal to make it more usable. **Zero** and **Range** in the Signal parameter list do this.

Analog zero

Zero Subtracts value entered from baseline. Press [**On/Yes**] to set to current **Value** or [**Off/No**] to cancel.

This is used to correct baseline elevation or offsets. A common application is to correct a baseline shift that occurs as the result of a valve operation. After zeroing, the analog output signal is equal to the **Value** line of the parameter list minus the **Zero** setpoint.

Zero can be programmed as a run time event. For details, see [“Run Time Programming”](#) on page 14.

- 1 Verify that the detector is on and in a ready state.
- 2 Press [**Analog Out 1**] or [**Analog Out 2**].
- 3 Scroll to **Zero**.
- 4 Press [**On/Yes**] to set **Zero** at the current signal value,
or
Enter a number between -500000 and +500000. A value smaller than the current **Zero** shifts baseline up.

Analog range

Range Scales data coming from the detector

Range is also referred to as gain, scaling, or sizing. It sizes the data coming from the detector to the analog signal circuits to avoid overloading the circuits (clamping). **Range** scales all analog signals.

If a chromatogram looks like A or B in the next figure, the data needs to be scaled (as in C) so that all peaks are visible on the paper.

Valid setpoints are from 0 to 13 and represent $2^0 (=1)$ to 2^{13} (=8192). Changing a setpoint by 1 changes the height of the chromatogram by a factor of 2. The following chromatograms illustrate this. Use the smallest possible value to minimize integration error.

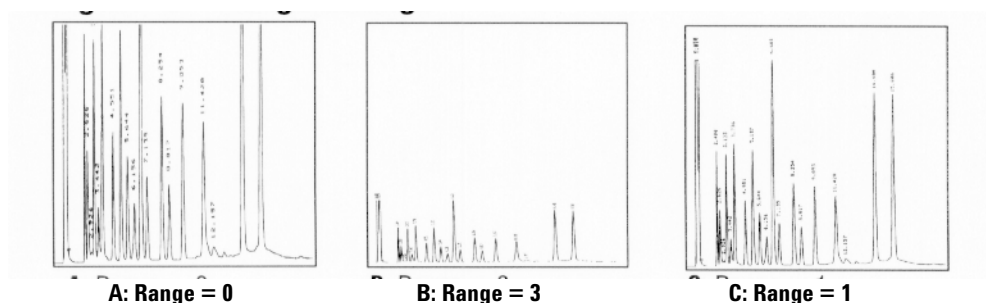

There are limits to usable range settings for some detectors. The table lists the valid range setpoints by detector.

Table 85 Range limits

Detector	Usable range settings (2 ^x)
FID	0 to 13
NPD	0 to 13
FPD	0 to 13
TCD	0 to 6
uECD	0 to 6
Analog input	0 to 7

Range may be run time programmed. See “[Run Time Programming](#)” on page 14 for details.

Analog data rates

Your integrator or recorder must be fast enough to process data coming from the GC. If it cannot keep up with the GC, the data may be damaged. This usually shows up as broadened peaks and loss of resolution.

Speed is measured in terms of bandwidth. Your recorder or integrator should have a bandwidth twice that of the signal you are measuring.

The GC allows you to operate at two speeds. The faster speed allows minimum peak widths of 0.004 minutes (8 Hz bandwidth), while the standard speed allows minimum peak widths of 0.01 minutes (1.6 Hz bandwidth).

If you use the *fast peaks* feature, your integrator should operate at around 15 Hz.

Selecting fast peaks (analog output)

- 1 Press **[Config][Analog 1]** or **[Config][Analog 2]**.
- 2 Scroll to **Fast peaks** and press **[On]**.

Agilent does not recommend using **Fast peaks** with a thermal conductivity detector. Since the gas streams switch at 5 Hz, the gain in peak width is offset by increased noise.

Digital Signals

The GC outputs digital signals only to an Agilent data system. The following discussions describe features that impact the data sent to data systems, not the analog data available to integrators.

Digital zero

Digital signal outputs respond to the **Zero** command by subtracting the signal level at the time of the command from all future values.

Baseline level shifts

Some run time operations, such as changing signal assignment or switching a valve, can produce large changes in the signal baseline position. This can complicate signal processing by external devices. The GC provides two run table commands to minimize such problems with digital output—see [“Run Time Programming”](#) on page 14.

Store signal value Saves the value of the signal at the time of the command.

Signal zero – value Creates a new zero by subtracting the stored value from the current value of the signal and applies this zero to all future values.

When these commands surround a baseline- shifting command, the effect is to bring the new baseline to the previous level, as shown in the next figure.

The **Store signal value** event must occur before the event that shifts the baseline, and the **Signal zero – value** event must occur after the baseline has stabilized at the shifted level.

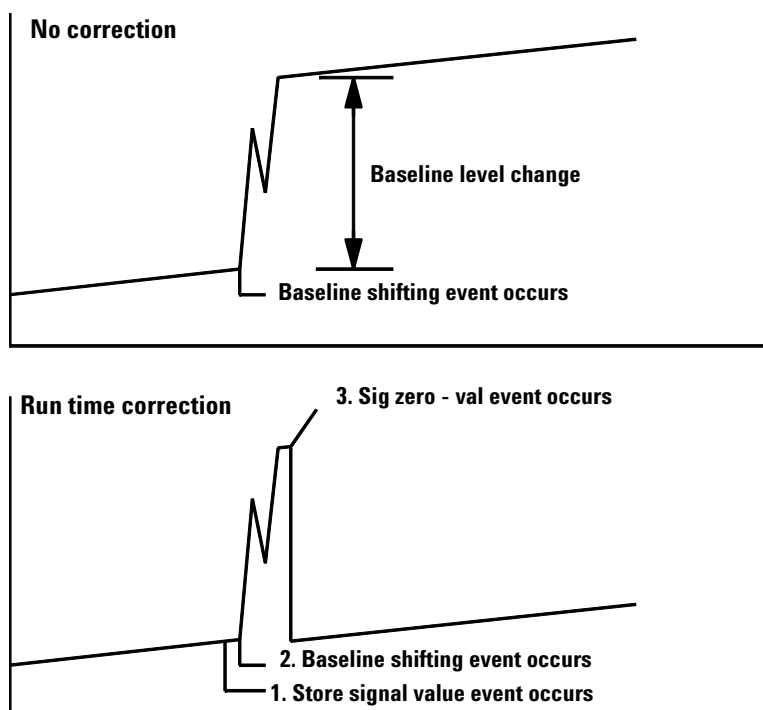

Agilent data systems

The GC can process data at various data rates, each corresponding to a minimum peak width. The table shows the effect of data rate selection.

Table 86 EZChrom Elite/ChemStation data processing

Data rate, Hz	Minimum peak width, minutes	Relative noise	Detector	Column type
500	0.0001	5	FID	Narrow-bore, 0.05 mm
200	0.001	3.1	FID	Narrow-bore, 0.05 mm
100	0.002	2.2	FID/FPD/NPD only	Capillary
50	0.004	1.6		
20	0.01	1		
10	0.02	0.7		
5	0.04	0.5		to
2	0.1	0.3	All types	

Table 86 EZChrom Elite/ChemStation data processing (continued)

Data rate, Hz	Minimum peak width, minutes	Relative noise	Detector	Column type
1	0.2	0.22		
0.5	0.4	0.16		
0.2	1.0	0.10		
0.1	2.0	0.07		Slow packed

You cannot change the data rate during a run.

You will see higher relative noise at the faster sampling rates. Doubling the data rate can double peak height while the relative noise increases by 40%. Although noise increases, the signal-to-noise ratio is better at the faster rates.

This benefit only occurs if the original rate was too low, leading to peak broadening and reduced resolution. We suggest that rates be chosen so that the product of data rate and peak width in seconds is about 10 to 20.

The figure shows the relationship between relative noise and data rates. Noise decreases as the data rate decreases until you get to data rates of around 5 Hz. As the sampling rate slows, other factors such as thermal noise increase noise levels.

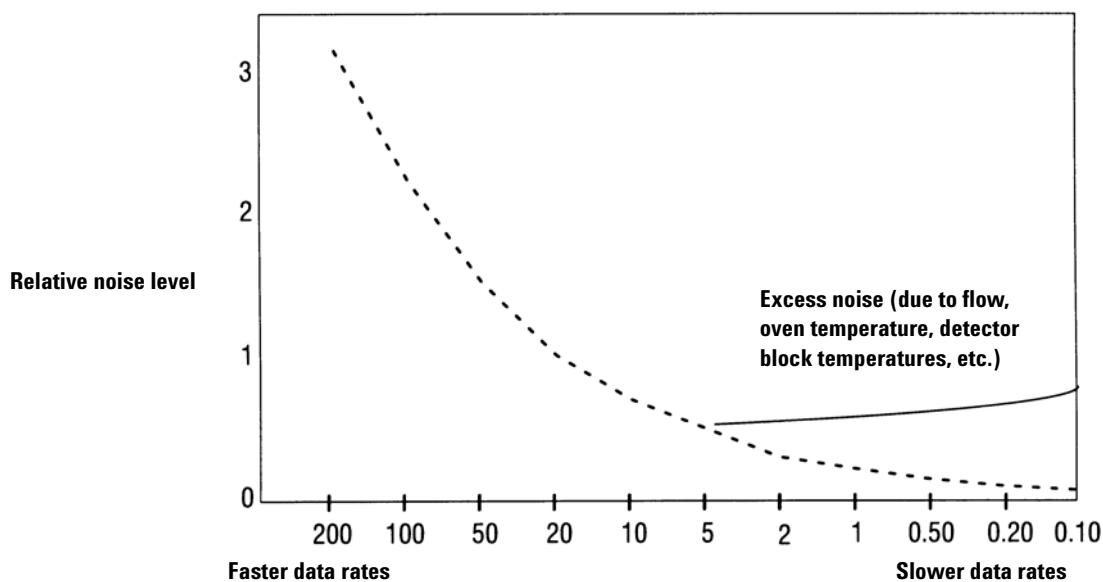

Zero Init Data Files

This feature applies to digital output only, and is mainly intended for non- Agilent data systems. It may help systems that have trouble with non- zero baseline output.

When you turn it **On**, the GC immediately begins to subtract the current detector output value(s) from any future values. For example, if you turn it on when the output is 20 pA, the GC subtracts 20 pA from the digital output until you turn Zero Init Data Files **Off**.

You will not see any change in the GC display, but you will see the change in the online plot available in the data system.

Column Compensation

In temperature programmed analysis, bleed from the column increases as the oven temperature rises. This causes a rising baseline which makes peak detection and integration more difficult. Column compensation corrects for this baseline rise.

A column compensation run is made with no sample injected. The GC collects an array of data points from all 4 detectors, whether installed, off, or working. If a detector is not installed or is turned off, that part of the array is filled with zeros.

One array (Column compensation 1) can be created for analog signals. Two independent arrays (Column compensation 1 and 2) can be created for digital signals.

Each array defines a set of curves, one for each detector, that can be subtracted from the *real* run to produce a flat baseline. The next figure illustrates the concept.

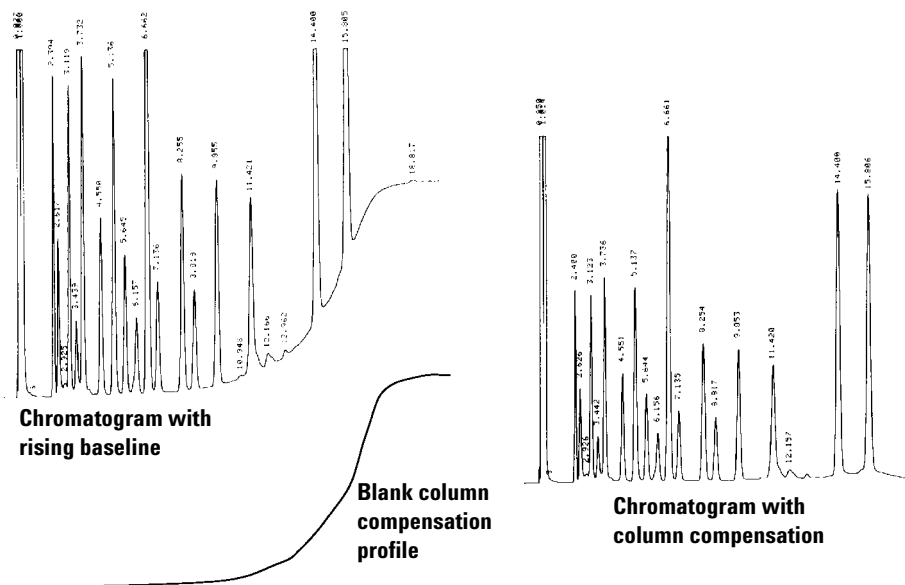

All conditions must be identical in the column compensation run and the *real* run. The same detector and column must be used, operating under the same temperature and gas flow conditions.

Creating a column compensation profile

- 1 Set up the instrument for a run.
- 2 Make a blank run to verify that the baseline is clean. This is particularly important for new conditions or if the GC has been idle for several hours.
- 3 Press [**Column Comp**].
- 4 Select **Col comp 1** or **Col comp 2** (these are the two arrays).
- 5 Select **Start compensation run** and press [**Enter**].
- 6 If the run is successful, the first line of the parameter list will say **Data ok**, and a time and date will appear at the bottom.

Making a run using analog output column compensation

- 1 Set the chromatographic conditions. They must be identical to those in the stored column compensation run except that **Final time** in the last ramp of the oven program can be longer or shorter.
- 2 Press [**Analog Out 1**] or [**Analog Out 2**].
- 3 Scroll to **Type** and press [**Mode/Type**].
- 4 The choices for an analog signal are:
 - Front detector
 - Back detector
 - Front - column comp 1
 - Front column compensation 1
 - Back column compensation 1
 - Aux 1 column compensation 1
 - Aux 2 column compensation 1
 - Test plot
- 5 Choose an option from the list.
- 6 Enter setpoints for **Zero** and **Range**, if applicable.
- 7 Start your run.

Making a run using digital output column compensation

- 1 Set each detector output separately.
- 2 Press [**Config**][**Detector name**]. Scroll to **Signal** and press [**Mode/Type**]. Select from:
 - No Column Compensation
 - Detector - ColComp 1
 - Detector - ColComp 2

This changes the digital output. You cannot get both compensated and uncompensated digital data from the same detector at the same time. However, it does not affect the analog output.

Plotting a stored column compensation profile

- 1 Press [**Analog Out 1**] or [**Analog Out 2**].
- 2 Scroll to **Type:** and press [**Mode/Type**].
- 3 Select the profile to be plotted.
- 4 Press [**Start**].

Test Plot

Test plot is an internally generated “chromatogram” that can be assigned to a signal output channel. It consists of three baseline-resolved, repeating peaks. The area of the largest is approximately 1 Volt-sec, the middle one is 0.1 times the largest, and the smallest is 0.01 times the largest.

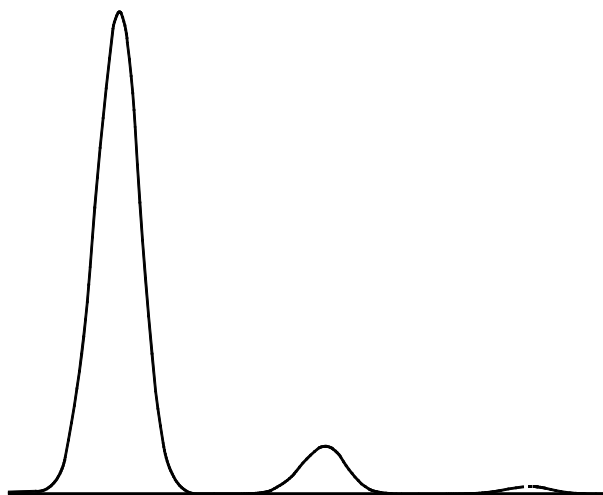

Test plot can be used to verify the operation of external data processing devices without having to perform repeated chromatographic runs. It may also be used as a stable signal to compare the results from different data processing devices.

To use the Test Plot:

- 1 Press [**Analog Out 1**] or [**Analog Out 2**].
- 2 Scroll to **Type:** and press [**Mode/Type**].
- 3 Choose **Test Plot**.
- 4 Press [**Start**]. The plot will repeat until you press [**Stop**].

Test Plot is the default choice for the analog outputs.

14 GC Output Signals



15 Miscellaneous Topics

Auxiliary Devices	384
About Auxiliary Pressure Control	384
About Aux Thermal Zone Control	385
About Auxiliary Device Contacts	385
About the 24V Auxiliary Device Power Supply	385
About Auxiliary Columns	385
About Auxiliary Detectors	386
To Use the Stopwatch	387
Service Mode	388
Service Reminders	388

Auxiliary Devices

About Auxiliary Pressure Control

Pressure units

There are two common ways of expressing gas pressures:

psia Absolute pressure, measured relative to vacuum.

psig Gauge pressure, measured relative to atmospheric pressure. This name is used because most pressure gauges have one side of the sensing element exposed to the atmosphere.

The two measurements are related by:

$$psia = psig + atmospheric\ pressure$$

Two-channel pressure control module (PCM)

The PCM has two different channels. Channel 1 may be either flow or pressure controlled and may be flow/pressure programmed. It is essentially identical to the packed column inlet flow module (see [“About the Multimode Inlet”](#) on page 186).

Channel 2 is pressure only, but may be used in either a forward- or back- pressure mode by changing connections.

Both channels are controlled by the same parameter list. The first two lines are for channel 1; the remaining lines are for channel 2.

The forward- pressure mode requires the user to supply a downstream flow resistance, possibly a frit.

The back- pressure mode is most useful with gas sampling valves. By connecting the sample exit line from the valve to the vent fitting of the PCM, pressure in the sample loop can be controlled.

Three-channel auxiliary pressure controller (Aux PCM)

All channels are 3- ramp programmable. Up to three modules may be installed, for a total of 9 pressure-regulated channels.

Setting parameters for auxiliary pressure control

- 1 Press [**Aux EPC #**] and scroll to the channel you wish to control. Press [**Enter**].
- 2 Scroll to **Initial pressure**. Enter a value and press [**Enter**].
- 3 If desired, enter a pressure program using the **time** and **rate** functions.
- 4 Press [**On/Yes**] to apply **Initial pressure** and start the program.

About Aux Thermal Zone Control

There can be up to 3 aux thermal controlled zones.

These zones are 3- ramp programmable.

Run time events may be used to schedule specific temperatures during the run.

Setting parameters for the aux thermal zone control

- 1 Press [**Aux Temp #**] and scroll to the zone you wish to control. Press [**Enter**].
- 2 Scroll to **Temperature**. Enter a value and press [**Enter**].
- 3 Scroll to **Initial time**. Enter a value and press [**Enter**].
- 4 Scroll to **Rate 1**. Enter **0** to end the program here or a positive value to create a temperature program.

About Auxiliary Device Contacts

These contacts are controlled by the external valve drivers. See [“The external valve drivers”](#) on page 342.

About the 24V Auxiliary Device Power Supply

This is controlled by the external valve drivers. See [“The external valve drivers”](#) on page 342.

About Auxiliary Columns

Defines up to 6 columns (includes **Col 1** and **Col 2**).

- 1 Press [**Config**][**Aux Col #**] and enter a column number. Press [**Enter**].
- 2 Define/configure the column. See [“Column #”](#) on page 33 for details.

About Auxiliary Detectors

The GC supports up to two auxiliary detectors in addition to the Front and Back detectors that mount on the top of the oven.

Aux Det # 1 This can only be a TCD, and mounts in a carrier on the left side of the oven together with its flow module.

Aux Det # 2 This can only be an analog input board (AIB). It is used to receive and process data from a non- Agilent detector or other source.

To Use the Stopwatch

In the stopwatch mode, both the time (to 0.1 second) and reciprocal time (to 0.01 min^{-1}) are displayed. The stopwatch is useful when measuring flows with a bubble flowmeter.

- 1 Press [**Time**] and scroll to the **time =** line.
- 2 Press [**Enter**] to start the stopwatch.
- 3 Press [**Enter**] again to stop.
- 4 Press [**Clear**] to set to zero.

You can access other functions while the stopwatch is running. Press [**Time**] again to view the stopwatch display.

Service Mode

The [**Service Mode**] key presents the **Service Reminders** and other functions.

Service Reminders

Internal counters

This is a set of 12 counters that monitor the use of various items on the GC, such as syringes, septa, and columns. These counters only count runs and their definitions are fixed. You can set limits for each item; when a limit is reached, the **Service Due** light on the status board comes on. Examine the limits to identify the item that has reached its limit.

You may enter a limit for each item, reset a count to **0** by pressing [**Off/No**], or disable a counter by entering a limit of **0**.

Advanced counters

The GC provides storage for 64 advanced counters. They each have two thresholds, and the actions based on these counters can be: do nothing, turn on the **Service Due** light, or light the **Service Due** light and go **Not ready**.

Advanced counters are not accessible through the GC keyboard, except for the **Disable Advanced Counters** function of the Service Reminders. If they are not disabled, they continue to count, and continue to act on the set thresholds. This could cause the GC to become **Not ready**.

Since the advanced counters cannot be reset or manipulated without the Agilent G4600AA Lab Advisor software, **Disable Advanced Counters** is provided so that they can be turned off from the GC keyboard by someone who does not wish to use them, the Lab Advisor software, or an Agilent data system. These users should disable the advanced counters from the keypad to avoid possible problems.

Counters can be individually enabled (count or don't count), individually reset (start over), and individually set as counting elapsed seconds or runs. They can be assigned arbitrary "meanings", allowing you to set up counters for equipment of your choice.

Each counter has an ID that can be associated with a concept, such as front inlet gold seal, and can count the number of elapsed runs or seconds since the last reset, from which one can infer the gold-seal's in-service time or count.

A ChemStation can enable or disable individual counters in association with a method, so that only the counters for things used by the method advance.

Other functions

These are for use by trained Agilent personnel. They are described in the Service Manual.

